



PSG
250 de Copenhague
Saint-Augustin-de-Desmaures
Quebec, Canada
G3A 2H3

Installation and operating instructions for the MAX CADDY wood furnace

READ THE MANUAL THOROUGHLY
BEFORE OPERATING THE FURNACE

CERTIFIED ACCORDING TO CSA B415.1-10, CAN/CSA B366.1 M91, UL391 4TH EDITION 2006, CAN/CSA C22.2 NO.236-05, UL 1995 3RD EDITION 2003, CSA B140.4-04 AND UL 727 9TH EDITION 2006

FURNACE MODELS INCLUDED IN THIS MANUAL

MAX CADDY WOOD AND COMBINATION FURNACE
20kW/25kW and UH-Max Caddy

**Read these instructions carefully before installing
and operating your furnace.**

CONGRATULATIONS!

You have purchased one of the finest wood
or combination furnaces available on the market.

We are confident that your furnace will provide years of comfort and safe
operation.

Please keep this document!



45446E
07/09/2010

TABLE OF CONTENT

WOOD OR WOOD/ELECTRIC COMBINATION FURNACES	4
1. CHIMNEY AND DRAFT	4
2. SAFETY RULES	4
2.1 GENERAL REQUIREMENTS	4
2.2 ODOUR FROM THE PAINT	5
2.3 ASH DISPOSAL	5
2.4 CREOSOTE BUILD-UP AND REMOVAL	5
2.5 SMOKE DETECTOR.....	6
2.6 DOOR GLASS	6
2.7 GLASS SPECIFICATIONS	6
2.8 ASH DRAWER	6
2.9 ASH GRATE	6
3. APPLIANCE INSTALLATION	7
3.1 COLD AIR RETURN BOX INSTALLATION.....	8
3.2 COLD AIR DUCTING SUPPORT INSTALLATION.....	10
3.3 LIMITING BOARD INSTALLATION AND CONNECTION	13
3.4 RTD SUPPORT BRACKET INSTALLATION AND CONNECTION	15
(RESISTANCE TEMPERATURE DETECTOR)	15
3.5 SERVOMOTOR INSTALLATION AND CONNECTION.....	17
3.6 HANDLES INSTALLATION.....	19
3.7 UNIT LOCATION	19
3.8 CLEARANCES TO COMBUSTIBLE MATERIALS	20
3.9 FLUE AND BAROMETRIC DRAFT CONTROL CONNECTION	21
3.9.1 <i>Damper</i>	22
3.10 FRESH AIR INTAKE ADAPTER INSTALLATION (OPTIONAL).....	22
3.11 PARALLEL INSTALLATION	24
3.12 ELECTRICAL ELEMENT INSTALLATION – WOOD-ELECTRIC MAX CADDY	25
(OPTIONAL).....	25
3.13 THERMOSTAT INSTALLATION	26
3.13.1 <i>Wood furnace only</i>	26
3.13.2 <i>Combination wood-electric or wood-oil furnace</i>	26
3.13.3 <i>Trio furnace (wood-oil-electric or wood-electric-oil)</i>	26
3.14 INSTALLATION OF A DOMESTIC WATER PRE-HEATING SYSTEM (OPTIONAL).....	26
3.15 INSTALLATION OF AN AIR CONDITIONING UNIT.....	26
3.16 OIL BURNER INSTALLATION – WOOD-OIL MAX CADDY (OPTIONAL).....	27
4. OPERATING INSTRUCTIONS.....	28
4.1 CONTROL SYSTEM.....	28
4.2 FIRST USE – GENERAL INFORMATION	28
4.3 FIRST USE - SETTINGS.....	28
4.3.1 <i>The use of the “BI-ENERGY” function</i>	29
4.4 FAN CONTROL.....	29

4.5	MODES, OPTIONS, AND PROGRAMMING	29
4.5.1	<i>The speeds</i>	29
4.5.2	<i>System Balancing</i>	31
4.5.3	<i>HEAT Mode (automatic heating)</i>	31
4.5.4	<i>COOL Mode (air conditioning)</i>	31
4.5.5	<i>CIRC (air circulation)</i>	32
4.5.6	<i>MANU (manual heating)</i>	32
4.5.7	<i>The Selections</i>	33
4.6	LIGHTING	33
4.7	PREHEATING	34
4.8	HEATING.....	34
4.9	EARLY SIGNS OF AN OVERFIRED FURNACE:	34
4.10	WOOD AS HEATING FUEL.....	35
4.11	PROLONGED POWER FAILURE.....	35
4.12	CHIMNEY FIRES	35
5.	MAINTENANCE.....	36
5.1	MAINTENANCE OF THE EXCHANGERS	36
5.2	CHIMNEY MAINTENANCE	37
5.3	MAINTENANCE OF THE BLOWER MOTOR.....	37
5.4	FILTERS	37
5.5	DOOR GASKET MAINTENANCE	37
6.	REPLACEMENT PARTS	38
6.1	DOOR GLASS	38
6.2	GASKET.....	38
7.	GENERAL ELECTRIC DIAGRAM WITH BECKETT OIL BURNER.....	39
8.	GENERAL ELECTRIC DIAGRAM WITH RIELLO OIL BURNER	40
9.	ELECTRIC DIAGRAM WITH OPTIONAL ELECTRICAL ELEMENT	41
10.	MAX CADDY TECHNICAL DATA.....	42
10.1	GENERAL TECHNICAL DATA	42
10.2	TECHNICAL DATA – ELECTRICAL ELEMENT	42
11.	MAX CADDY BRICKS LAYOUT	43
12.	TROUBLE SHOOTING	44
SECTION B.....		45
WOOD/OIL COMBINATION FURNACE		45
GENERAL NOTES		47
1. DRAFT AND CHIMNEY		47
2. OIL TANK AND PIPING.....		47
2.1	BURNER PUMP	47
3. APPLIANCE INSTALLATION		48
3.1	LOCATING THE UNIT	48

3.2	POSITIONING THE APPLIANCE.....	48
3.3	PIPE CONNECTOR AND DAMPER.....	49
3.4	POSSIBLE INSTALLATIONS.....	50
3.5	COMBUSTION AIR.....	51
3.6	ELECTRICAL WIRING.....	51
3.7	THERMOSTAT.....	51
3.8	FAN CONTROL.....	51
3.9	COMBUSTION SAFETY CONTROL.....	51
3.10	COMBUSTION ADJUSTMENT AND VERIFICATION.....	52
3.11	ELECTRODES SETTING.....	53
4-	APPLIANCE START-UP.....	53
5-	PROLONGED CLOSING.....	53
6-	MAINTENANCE.....	54
7-	ELECTRICAL DIAGRAMS.....	55
8-	TECHNICAL DATA.....	57
8.1	UH – MAX CADDY.....	57
	LIMITED LIFETIME WARRANTY.....	58

REGISTER YOUR WARRANTY ONLINE

To receive full warranty coverage, you will need to show evidence of the date you purchased your furnace. Keep your sales invoice. We also recommend that you register your warranty online at www.psg-distribution.com

Registering your warranty online will help us track rapidly the information we need on your furnace.

IMPORTANT NOTE:

THE INSTALLATION OF THIS CENTRAL HEATING SYSTEM MUST BE PERFORMED BY A QUALIFIED TECHNICIAN. PSG RESERVES ITSELF THE RIGHT TO VOID ITS WARRANTY OR DENY TECHNICAL ADVICE IF THE FURNACE HAS NOT BEEN SOLD OR INSTALLED BY A PROFESSIONAL.

WARNING : THE INSTALLATION OF THIS APPLIANCE REQUIRES THE ADDITION OF A BLOWER BOX & ELECTRONIC FAN LIMIT KIT (#PA08565)

SECTION A:

WOOD OR WOOD/ELECTRIC COMBINATION FURNACES

Take note that this furnace operates like an EPA wood burning stove. This applies to the lighting, the ember bed, and the minimum combustion air intake which was determined based on the use of good seasoned cordwood.

The Max Caddy furnace was tested and approved according to the CSA B415.1-10 Standard.

To optimize the efficiency of your furnace, here is some advice that you should follow when installing or operating your Max Caddy.

- Respect the local codes (when in doubt, consult your local dealer);
- Make sure your furnace is installed according to the instructions on the certification label;
- All controls and adjustments must be performed by a qualified technician. The blower speed must conform to the recommendations of local codes and should respect the static pressure ranges in the warm air plenum of the furnace.

1. CHIMNEY AND DRAFT

This furnace must be connected to a chimney certified for use with wood burning heating appliances. A 7-inch chimney and connector are recommended for the Max Caddy if it is used as a wood-oil unit or a wood-oil-electric unit. If an oil option may be installed in the future, we also recommend a 7-inch chimney. If the furnace is to be used as a wood only unit, then a 6-inch chimney is recommended.

The unit is not to be connected to a chimney flue serving another appliance.

If the chimney draft exceeds 0.06 IN.W.C., a barometric draft control should be installed on the smoke pipe. Never install a manual damper.

The barometric control must be adjusted so that the maximum draft measured at the furnace outlet does not exceed -0.06 IN.W.C. Please note that a draft exceeding 0.06 IN.W.C. will reduce the efficiency and could produce an uncontrollable fire. **On the other hand, the minimum draft required is 0.04 IN.W.C. in the evacuation pipe on the wood side, no matter what type of furnace (WOOD, WOOD / ELECTRIC OR WOOD / OIL).**

The adjustment should in no case be modified to increase combustion.

2. SAFETY RULES

2.1 GENERAL REQUIREMENTS

- Make sure the chimney outlet and the pipes are clean and in good condition.
- **DO NOT USE CHEMICAL PRODUCTS OR LIQUIDS TO LIGHT THE FIRE.**
- Do not burn wood coated with paint, glue or chemical products.
- **DO NOT BURN WASTES OR FLAMMABLE LIQUIDS SUCH AS GASOLINE, NAPHTHA, MOTOR OIL, OR OTHER UNSUITABLE MATTERS.**
- Do not install an automatic feeder on this furnace.
- Do not store wood in the vicinity of the furnace. Respect the required clearances between combustible materials and the source of heat.

WARNING

- THE ASH DRAWER AND EXCHANGERS ACCESS PANEL GET VERY HOT.
- DO NOT MANIPULATE WITH BARE HANDS.

2.2 ODOUR FROM THE PAINT

It is normal that smoke and odours emanate from the unit when you first light it. It is recommended to burn it at high rate and ventilate the building until the odours disappear. The smoke is not toxic.

2.3 ASH DISPOSAL

Ashes must be placed in a metal container with a tight fitting lid. The container should be stored outdoors, well away from combustible materials. This container should not receive any other type of waste. If the ashes are meant to be buried in soil, wait until all embers have thoroughly cooled before burying.

2.4 CREOSOTE BUILD-UP AND REMOVAL

When wood is burned slowly, it produces tar and other organic vapours which, when combined with moisture, form creosote. The creosote vapours condensate in a relatively cool chimney flue. As a result, creosote residues accumulate inside the flue lining and the exchangers.

N.B.: To minimize the frequency of the chimney cleaning, buy your firewood at least one year before using it. Store it in a dry place in order to obtain the minimum moisture rate and optimize the efficiency. Do not store wood or combustible materials within the installation minimum clearances or the space required to reload the appliance and remove ashes.

When ignited, creosote produces an extremely hot fire inside the chimney.

In the first year of use, in order to avoid chimney fires, inspect the chimney system at regular intervals to determine a cleaning cycle. Depending on the type of wood used and its quality, a semi-annual cleaning may be required. A yearly cleaning is mandatory.

If a significant layer of creosote has accumulated, it must be removed immediately to eliminate the risk of chimney fire.

Remember that a small, hot fire is preferable to a large smouldering one to prevent creosote build-ups within the system. Prepare an emergency procedure in case of a chimney fire.

It is recommended to clean the heat exchangers thoroughly at the end of season in order to prevent corrosion.

2.5 SMOKE DETECTOR

We highly recommend the use of a smoke detector. It must be installed at least 15 feet (4,57 m) from the appliance in order to prevent undue triggering of the detector when reloading.

2.6 DOOR GLASS

To maintain a clean and safe installation, do not build your fire too close to the glass or allow logs to lean on the glass.

Do not operate your furnace at too low a setting. Keep the air inlet opened long enough during the fire start-up to prevent the fire from smouldering, which could stain the glass.

An intense fire will help keep the glass clean. However, in the event that your glass gets stained, which should not occur under normal operating conditions, you will have to clean it using a wet cloth and a fireplace glass cleaner. Clean the glass **ONLY** when the unit has cooled down. Do not use abrasive cleanser. Fireplace glass cleaners are available in most home centers and specialty hearth retailers.

WARNING: Avoid knocking or scratching the glass. I could crack or break.

2.7 GLASS SPECIFICATIONS

The glass is made of 3/16" (5mm) thick Pyroceram.

Do not operate your wood furnace with a broken glass, as this could seriously damage your furnace.

You can purchase a replacement glass from your PSG dealer.

2.8 ASH DRAWER

Your furnace is equipped with an ash drawer to collect ashes produced by the combustion of wood. This drawer must not be left open during combustion as this may cause over firing and serious damages to the furnace.

The drawer must be emptied regularly.

It is important that the door and the ash drawer be kept closed while the appliance is in use. Maintain all gaskets in good condition; in case of deterioration, contact your dealer for a genuine replacement gasket.

2.9 ASH GRATE

You must replace the ash grate if it is damaged and a replacement may be obtained from your dealer.

3. APPLIANCE INSTALLATION

The installation instructions of this section apply to the wood-only Max Caddy, the wood-electric Max Caddy, the wood-oil Max caddy, and the wood-oil-electric trio Max Caddy.

WARNING : THE INSTALLATION OF THIS APPLIANCE REQUIRES THE ADICTION OF A BLOWER BOX & ELECTRONIC FAN LIMIT KIT (#PA08565)

CAUTION: The following instructions do not supersede the local code.

Detailed content of the blower box & electronic fan limit kit (#PA08565):

<u>CONTENT OF THE BOX</u>
1 X BLOWER ASSEMBLY MANUAL KIT FOR MAX CADDY
27 X #10 X 1/2" "A" TYPE METAL SCREW
2 X 1/4-20 X 1" ELEVATOR BOLT
1 X 100 OHM RTD - 38" WIRE
1 X RTD SUPPORT
1 X #8 X 1/2" METAL SCREW
1 X 3/8" 1 SCREW CONNECTOR FOR BX WIRE
1 X RED PLASTIC SLEEVE FOR BX WIRE
2 X RED PLASTIC SLEEVE FOR BX WIRE (ANTI-SHORT SIZE-2)
1 X 3/4" SCREW CONNECTOR FOR BX WIRE

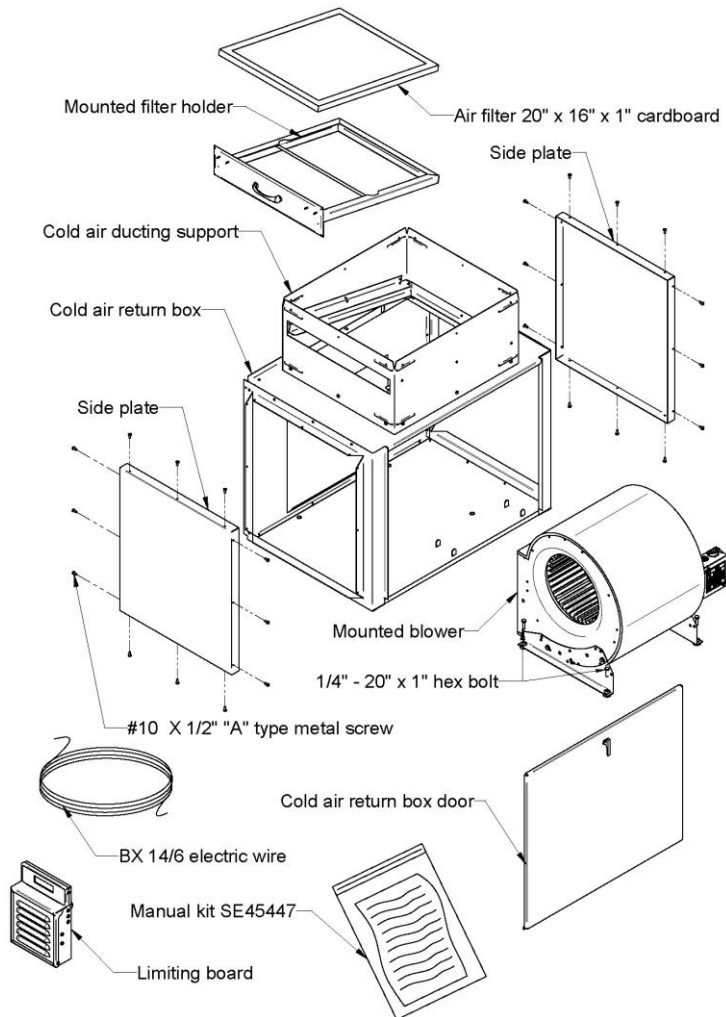

3.1 COLD AIR RETURN BOX INSTALLATION

Before installing the cold air return box, you need to remove the back panel gasket and the back panel as shown below. To do so, remove the 8 screws.

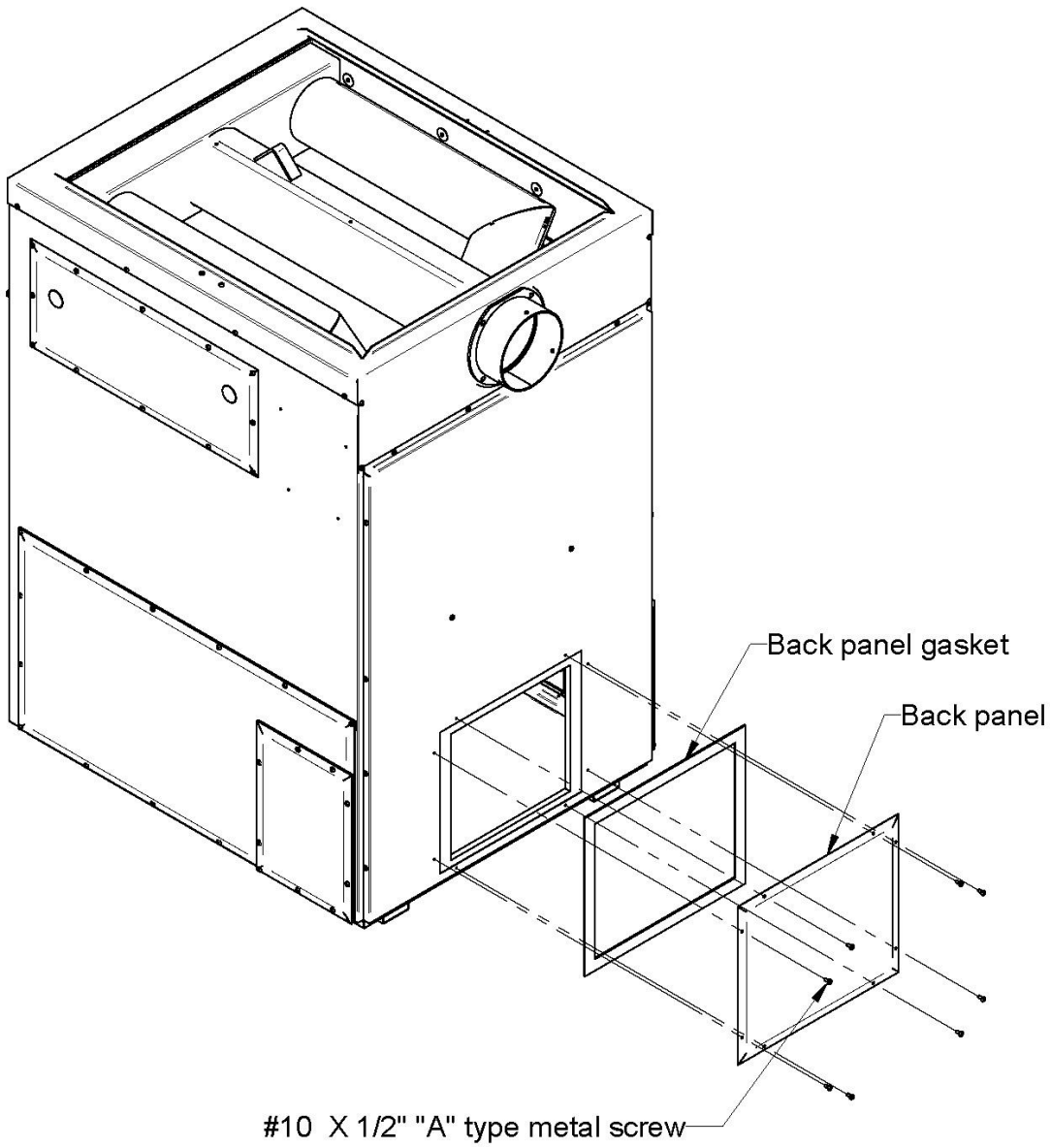

Remove the cold air ducting support from the cold air return box. To do so, remove the 12 screws as shown below. Keep these screws. You will need them to install the cold air ducting support in the new location.

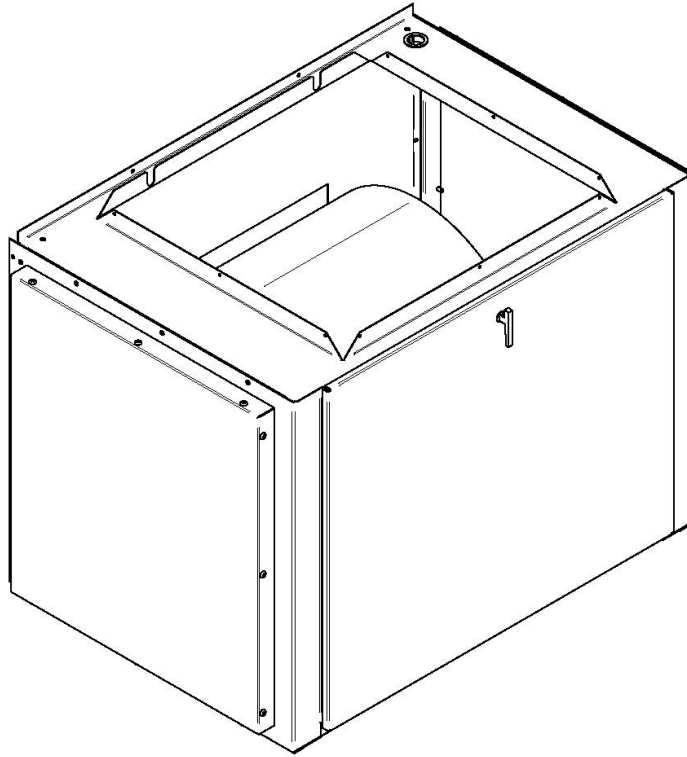
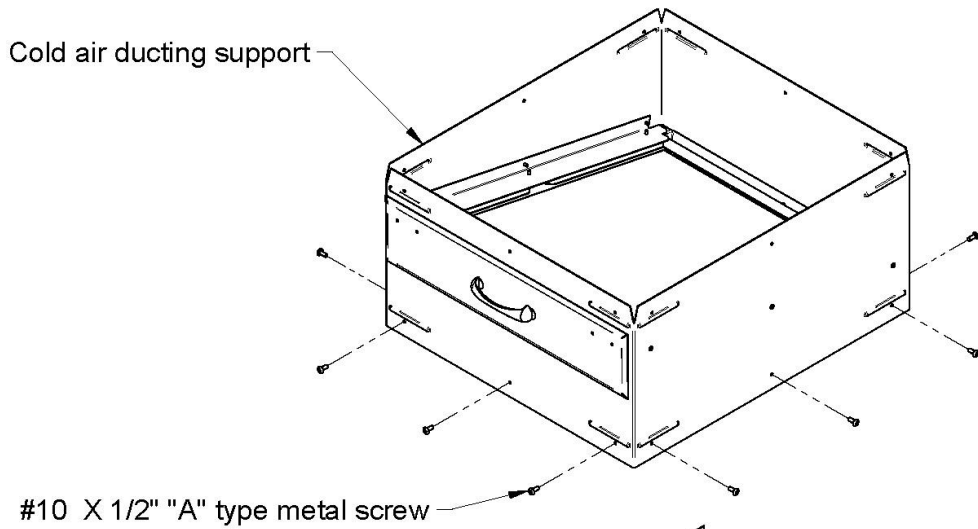

Then, secure the cold air return box to the furnace. To do so, use the 8 screws as shown below. Then, level the cold air return box by screwing or unscrewing the elevator bolts.

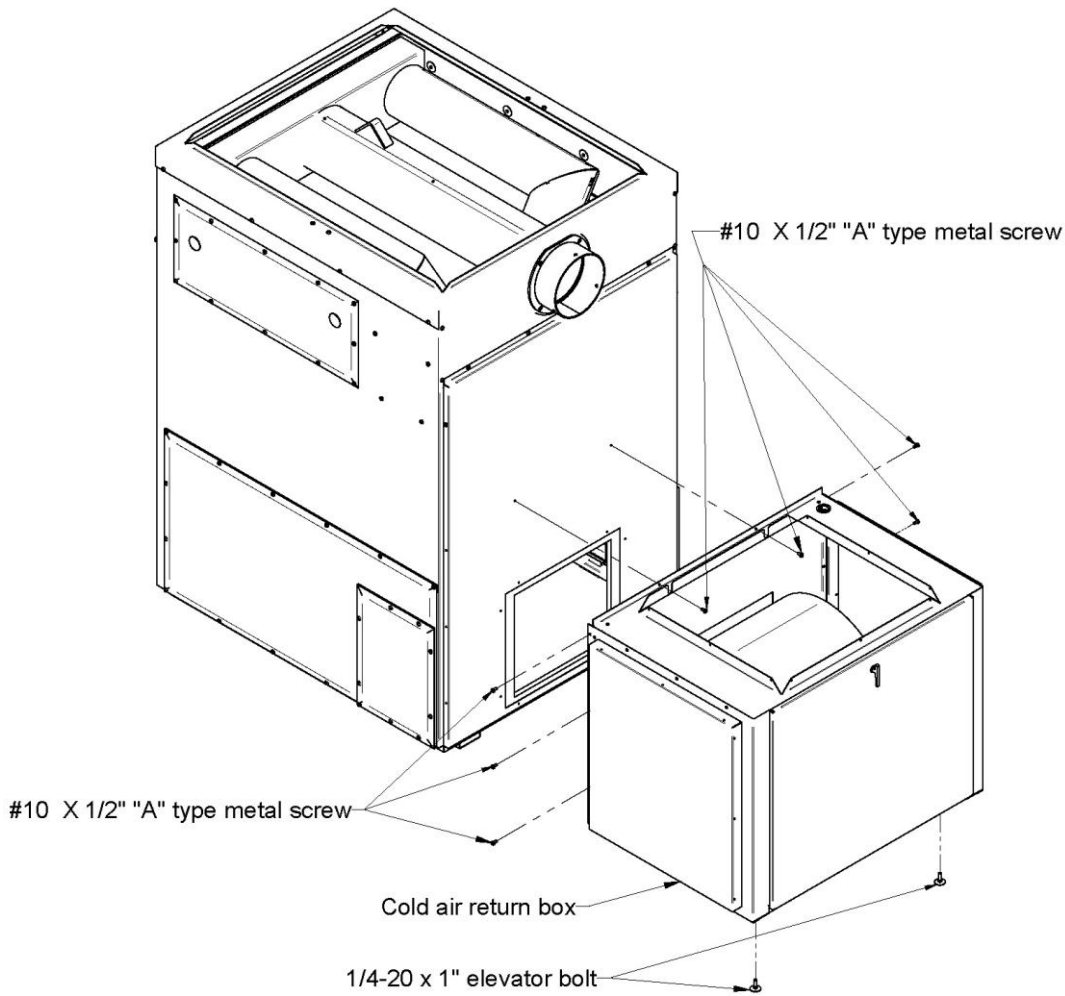

3.2 COLD AIR DUCTING SUPPORT INSTALLATION

On the cold air return box, you will find two side plates and the cold air return box door. The cold air ducting support can be configured in several ways. You have the flexibility to choose the desired configuration depending on your installation. Indeed, some installations have obstacles making the installation of the cold air ducting support difficult. Configurations differ depending on the chosen location of the cold air ducting support. You will find the different configurations in the following pages.

In order to realize the various configurations, you must remove the three screws retaining the side plate where you wish to install the cold air ducting support. Keep the screws which retained the side plate to install the side plate at the new desired location. The side plate and the cold air ducting support must be secured using nine screws each (kept from the previous step). Remaining screws are provided with the cold air return box.

Installation of the cold air ducting support at the **RIGHT** of the cold air return box

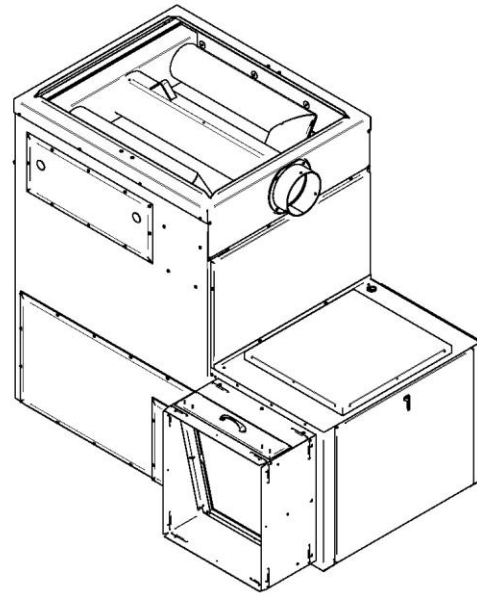
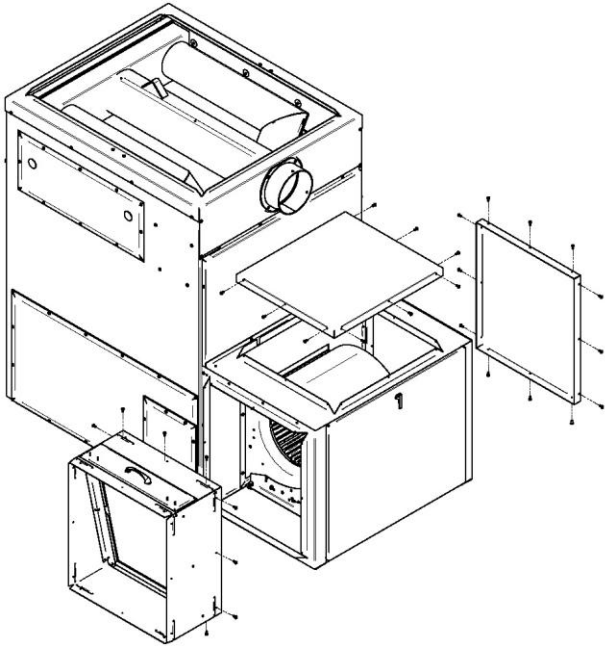

Installation of the cold air ducting support at the **LEFT** of the cold air return box

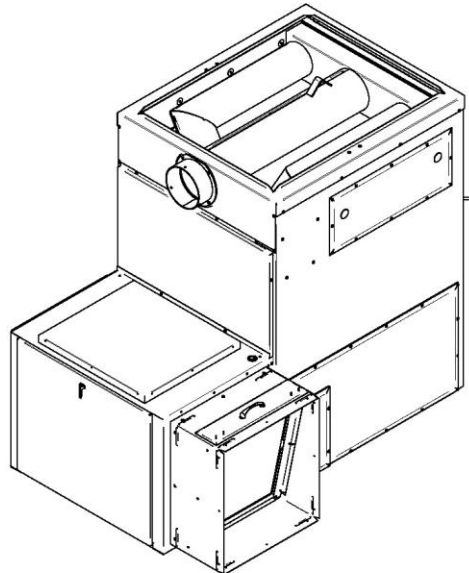
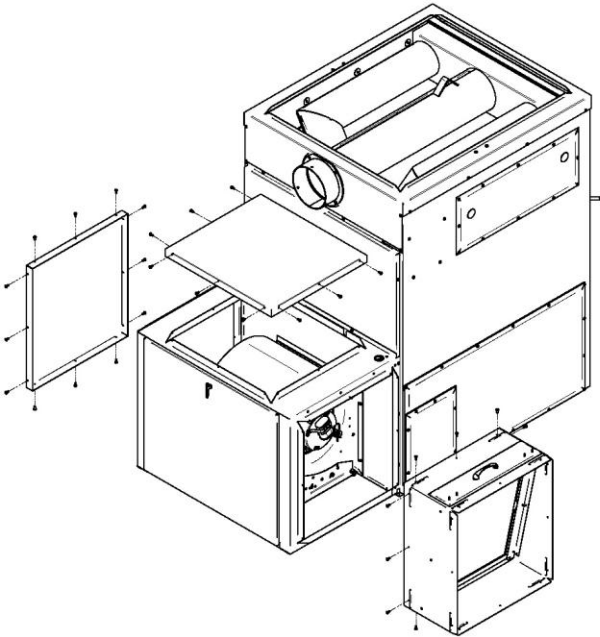

Installation of the cold air ducting support **ON TOP** of the cold air return box with filter exit towards the **RIGHT**

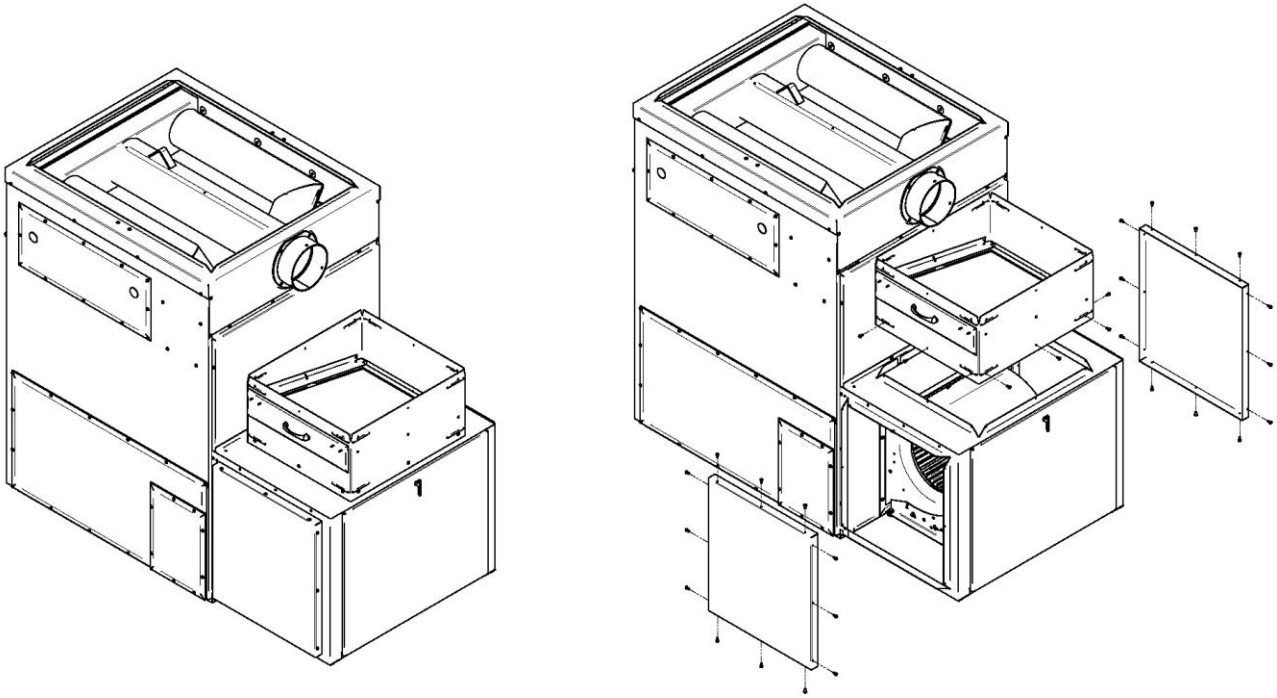

Installation of the cold air ducting support **ON TOP** of the cold air return box with filter exit towards the **LEFT**

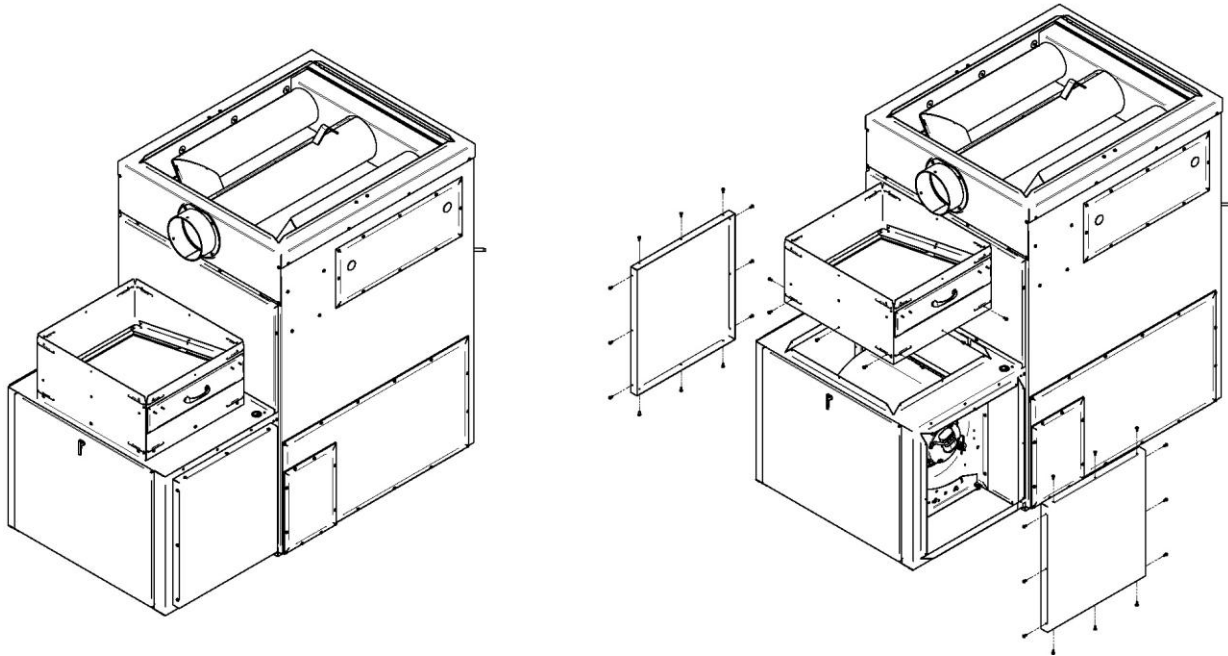

3.3 LIMITING BOARD INSTALLATION AND CONNECTION

The limiting board may be installed on either side of the furnace. Remove the 4 screws secured on the side of the furnace where you wish to install the limiting board, either on the left or on the right side, and keep these screws. Remove the access panel of the limiting board. Secure the limiting board where you removed the screws from the furnace. Refer to the electric wiring diagram in section 7 for the electrical connections. Do not screw the access panel back on the limiting board until all connections are made.

Limiting board installed on the **RIGHT** side of the furnace

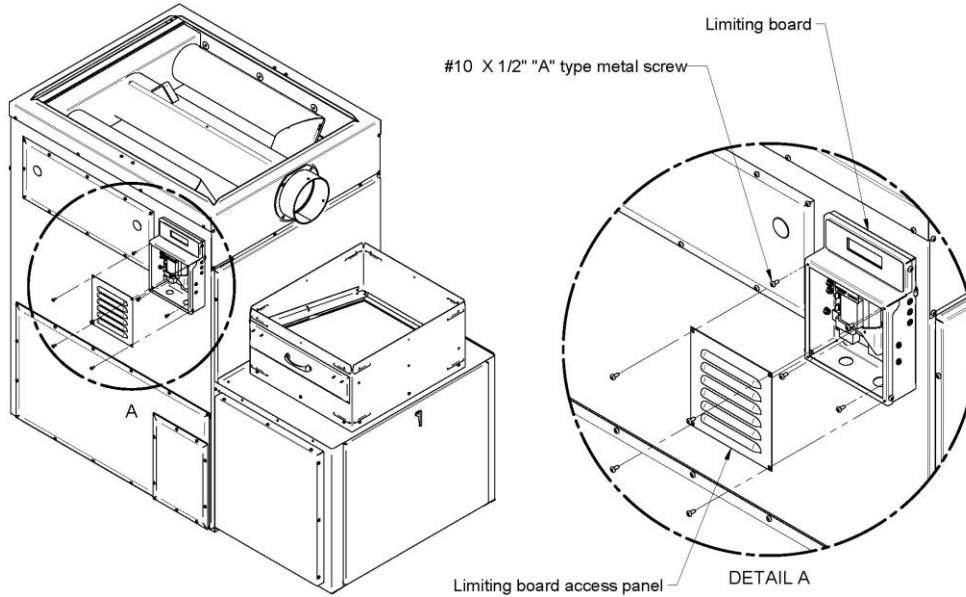

Limiting board installed on the **LEFT** side of the furnace

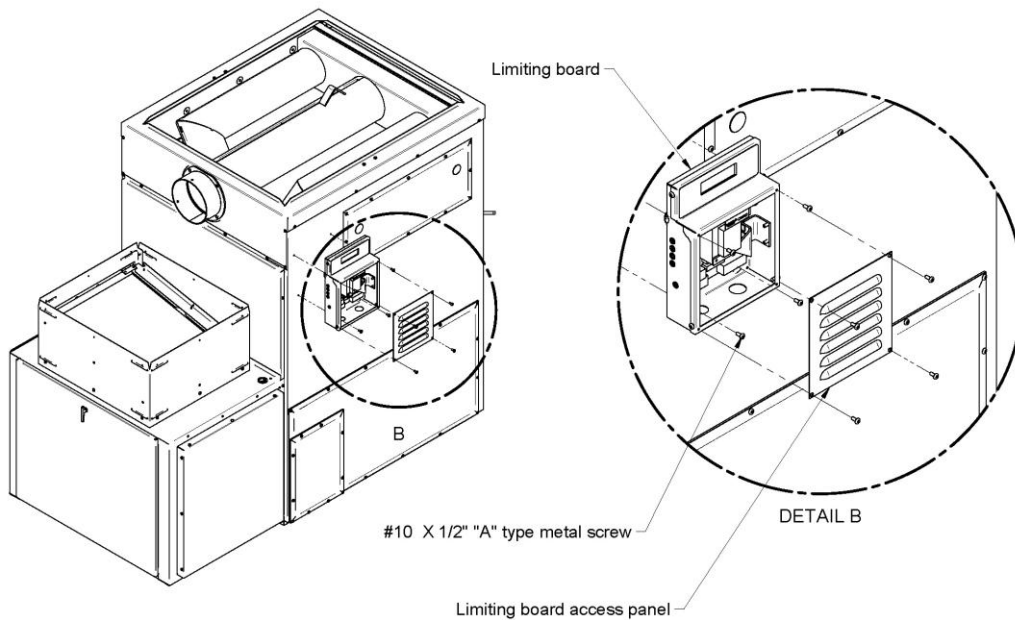

Now, it is time to make the connection between the limiting board and the blower. Since the limiting board may be installed on either side of the furnace, refer to the drawings below to run the wire properly.

Limiting board installed on the **RIGHT** side of the furnace

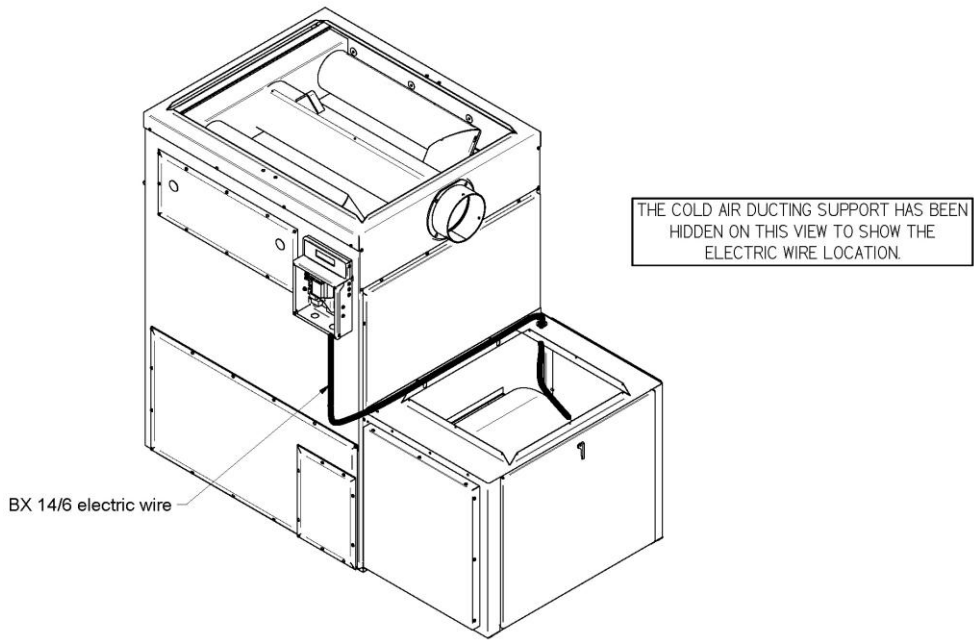

Limiting board installed on the **LEFT** side of the furnace

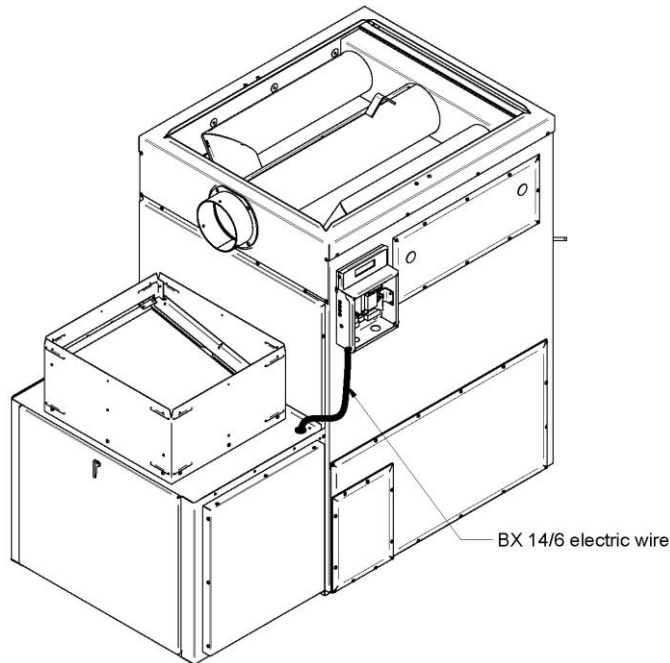

3.4 RTD SUPPORT BRACKET INSTALLATION AND CONNECTION (resistance temperature detector)

Your Max Caddy furnace is equipped with a RTD probe (resistance temperature detector). This RTD probe must be installed on the RTD support bracket. The RTD support bracket may be installed on left side or on the right side of the furnace. To install it, all you need to do is to screw it in place in the two pre-drilled holes as shown below.

RTD support bracket installed on the **RIGHT** side of the furnace

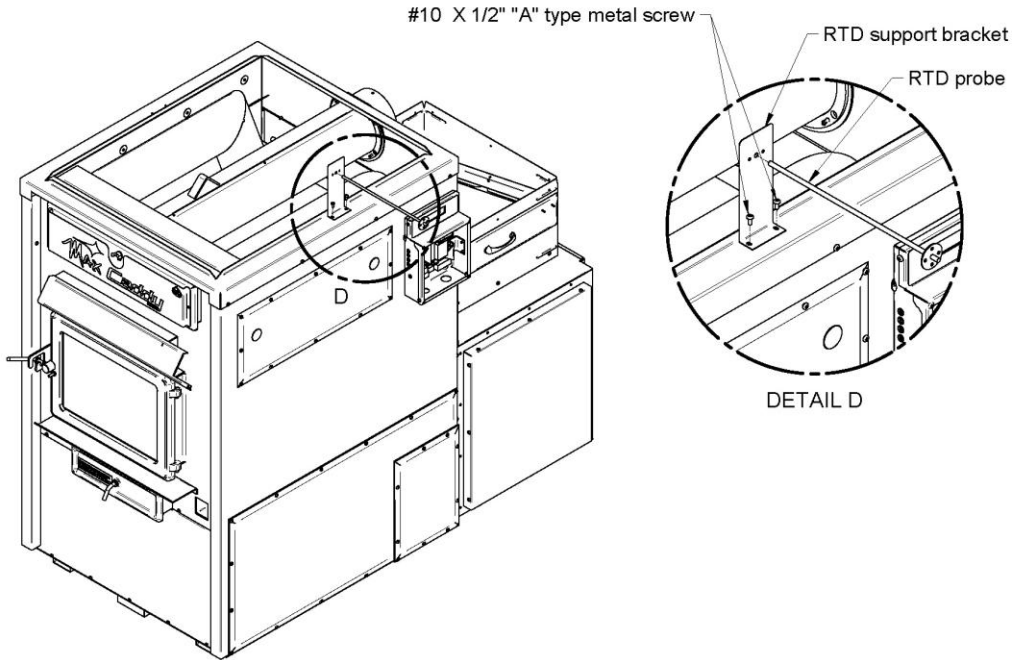

RTD support bracket installed on the **LEFT** side of the furnace

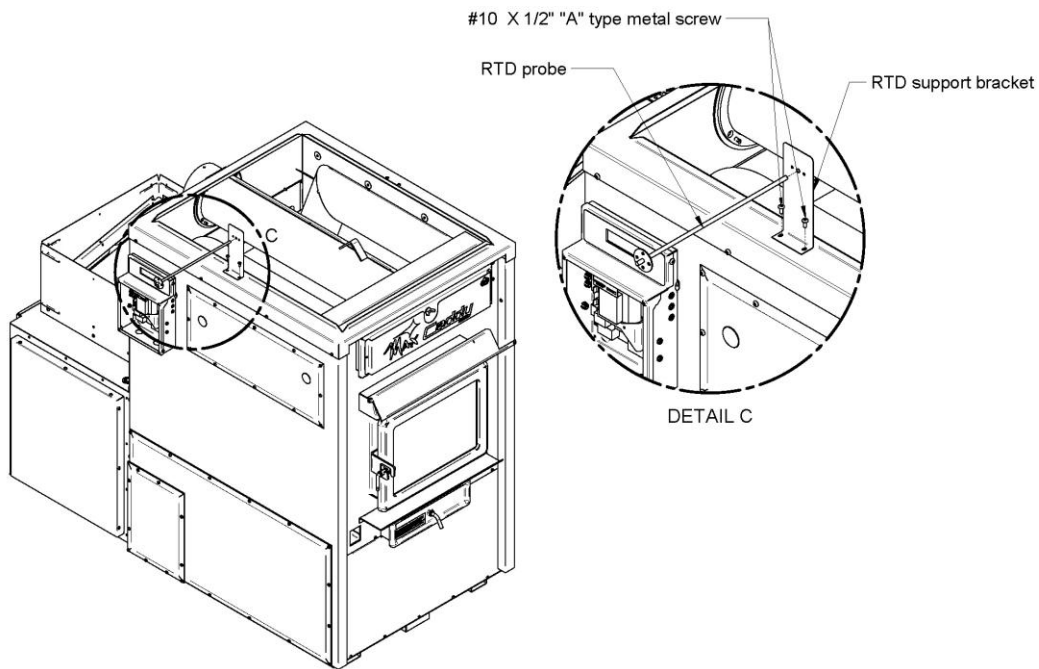

Once the RTD probe is installed on the RTD support bracket, you need to connect the RTD probe to the limiting board. To run the wire properly, refer to the drawings below. Refer to the electric wiring diagram in section 7 for the electrical connections.

RTD probe installed on the **RIGHT** side of the furnace

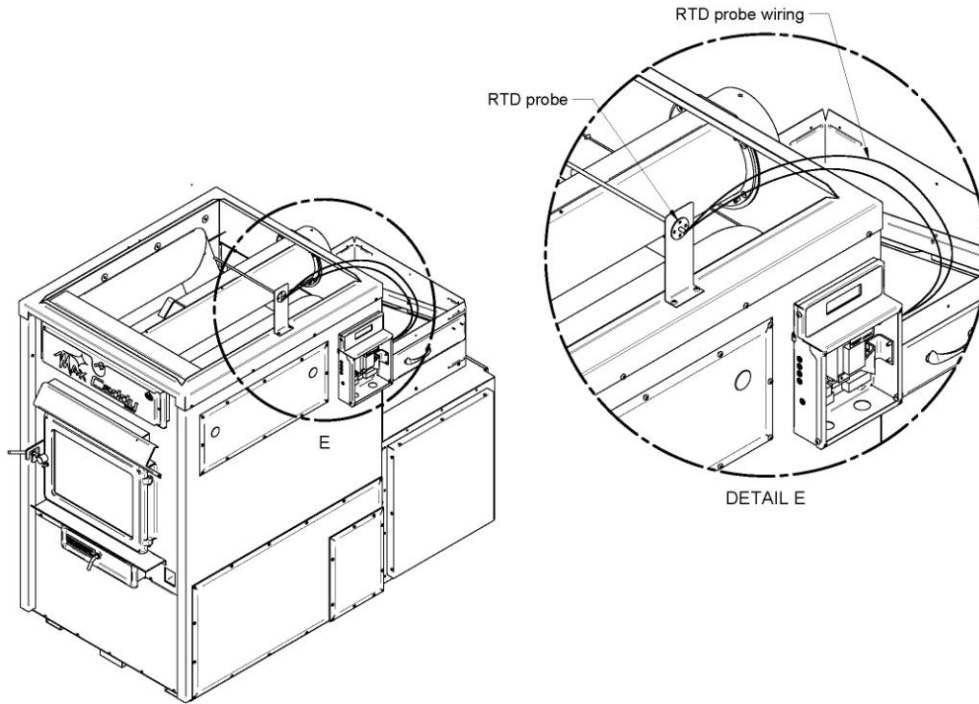

RTD probe installed on the **LEFT** side of the furnace

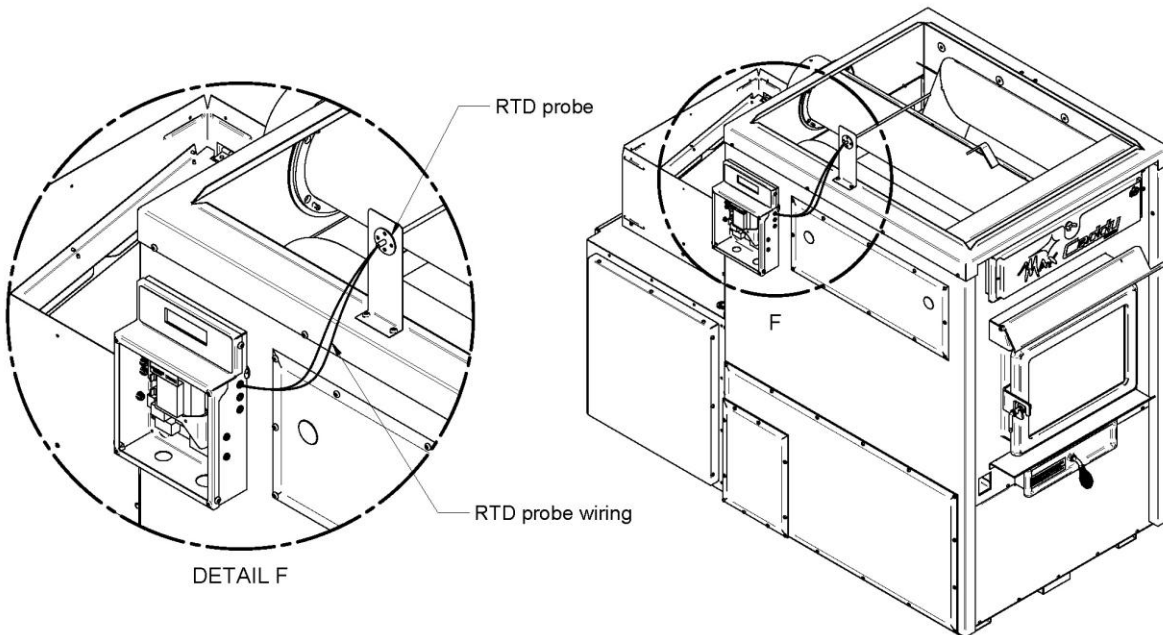

3.5 SERVOMOTOR INSTALLATION AND CONNECTION

Your Max Caddy furnace is equipped with a servomotor. You need to secure it in place in the two pre-drilled holes using two screws as shown below.

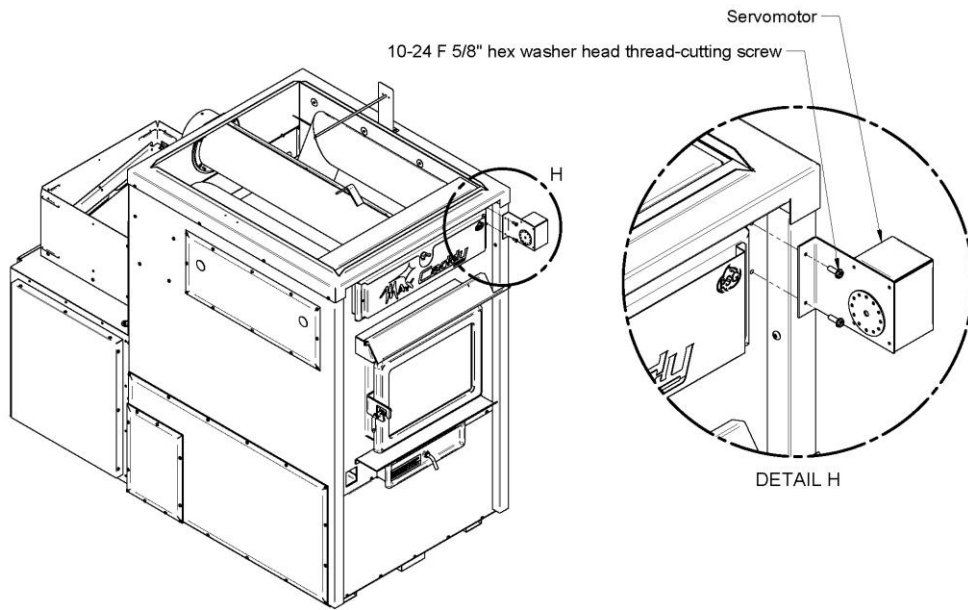

Once installed, you need to install the chain that links the air inlet damper to the servomotor as shown below. For more information regarding this installation, refer to the furnace owner's manual. The chain that links the air inlet damper to the motor must have a play of 1/8" and must be secured in place by the hook. When there is no call for heat, the air inlet damper must be completely closed and the chain must be hooked to the servo-motor at the "8 o'clock" position. Refer to the electric wiring diagram in section 7 for the electrical connections.

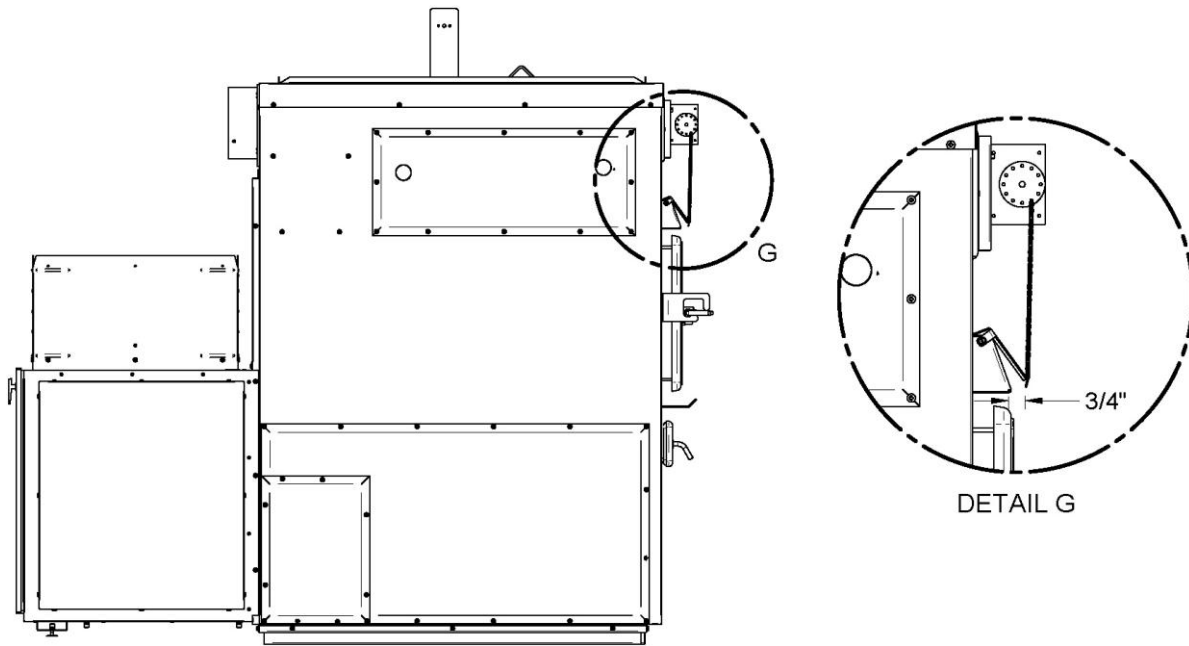

WARNING: USE WIRING SUITABLE FOR 75° C (not supplied)

Then, you need to connect the servomotor to the limiting board. To do so, refer to the electric wiring diagram in section 7. To run the wire properly, refer to the drawings below.

Wire running to the limiting board installed on the **LEFT** side of the furnace

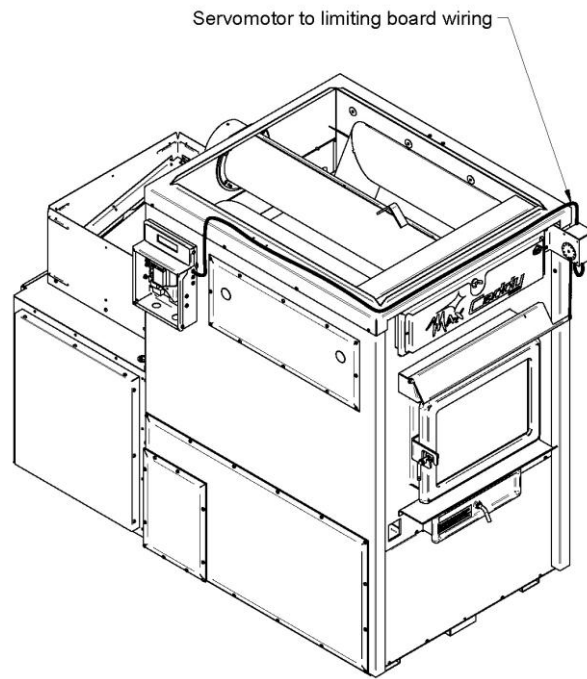

Wire running to the limiting board installed on the **RIGHT** side of the furnace

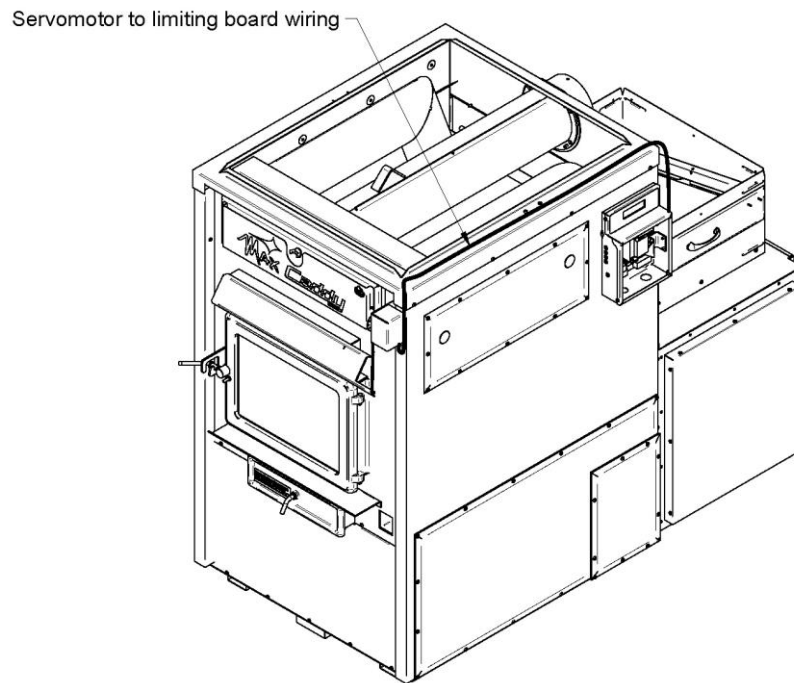

WARNING: USE WIRING SUITABLE FOR 75° C (not supplied)

3.6 HANDLES INSTALLATION

The following step consists of installing the handles on the handle rods of the ash drawer and the door as shown below.

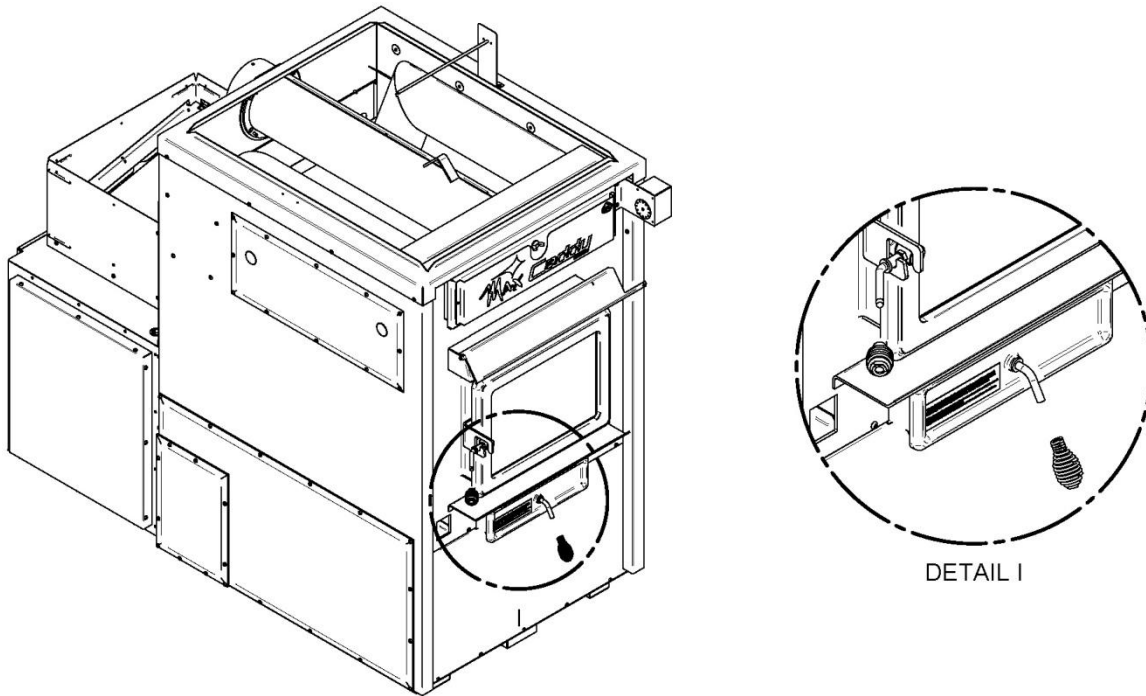

3.7 UNIT LOCATION

The furnace must be installed where outside air supply is sufficient for proper combustion. In airtight houses, it might be necessary to install an outside air intake.

The furnace must be positioned so that the connector is as short as possible; minimize the use of 90° elbows.

The owner must ensure a proper installation to allow for a safe operation of the appliance.

3.8 CLEARANCES TO COMBUSTIBLE MATERIALS

N.B. This appliance must be installed according to the instructions on the unit's certification label.

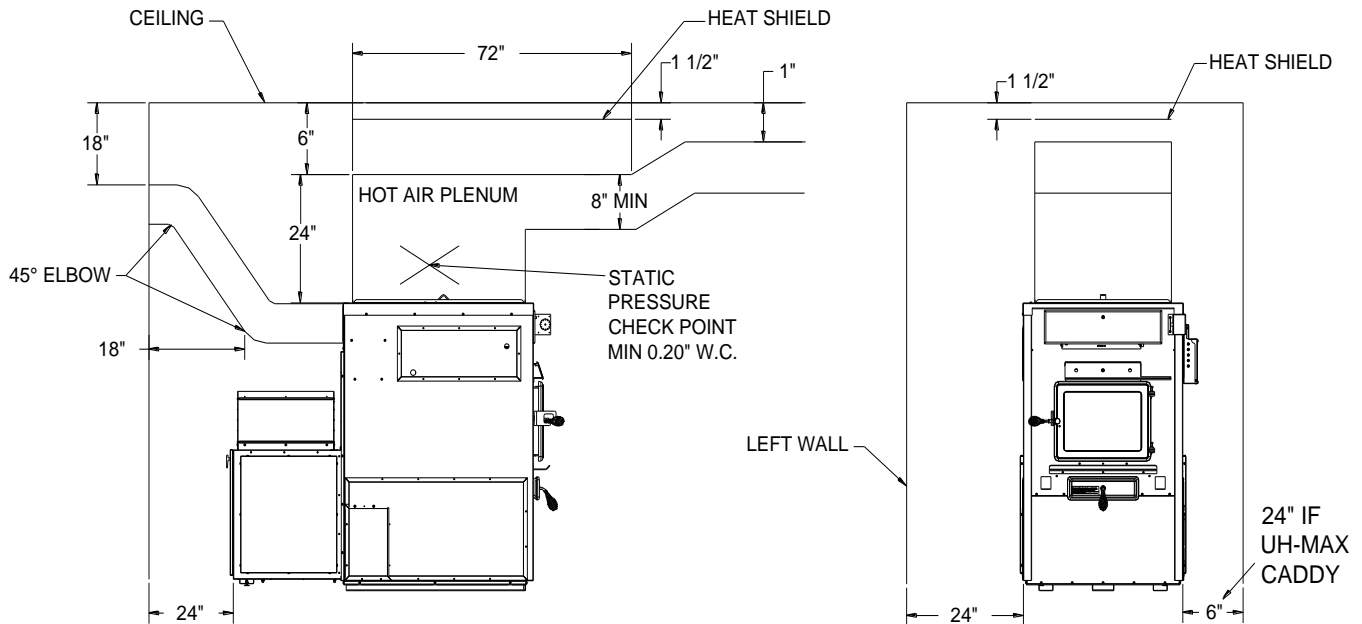

N.B. THE SIZE OF THE AIR RETURN DUCT SHOULD BE AT LEAST EQUAL TO THE SIZE OF THE COLD AIR PLENUM OPENING.

FIRST 6 FEET OF DUCT INCLUDING WARM AIR PLENUM	*6 in.(150 mm) with a shield at 1 1/2"
PLENUM AFTER THE FIRST 6 FEET	1 in. (25 mm)
REAR (INCLUDING CLEARANCE FOR MAINTENANCE)	24 in. (610 mm)
SIDES (INCLUDING CLEARANCE FOR MAINTENANCE)	24 in.(610 mm)
OIL BURNING UNIT FLUE PIPE	9 in.(230 mm)
WOOD BURNING FURNACE FLUE PIPE	18 in.(455 mm)
** FLOOR	0 in.(0 mm)

* Supplied with the furnace.

**The furnace can be installed on a combustible floor. The use of a floor protector exceeding the furnace by 8 inches on the sides and 18 inches in front is highly recommended.

3.9 FLUE AND BAROMETRIC DRAFT CONTROL CONNECTION

Before connecting the stove pipe, make sure you have removed any accessory from the flue pipe such as the scraper, shovel, and the poker.

The flue outlet on the Max Caddy furnace is 6" in diameter and the wood only or wood/electric models may be installed with a 6" chimney approved for use with wood burning heating appliances (2100°F). However, we recommend the use of a 7" chimney if the retrofit to a wood/oil configuration is probable. In that case, a 6" to 7" reducer must be installed at the flue outlet of the furnace. If the draft exceeds 0.06 IN.W.C., a barometric control must be installed. **Never install a manual damper.** Secure the exhaust pipe to the flue adapter with three screws.

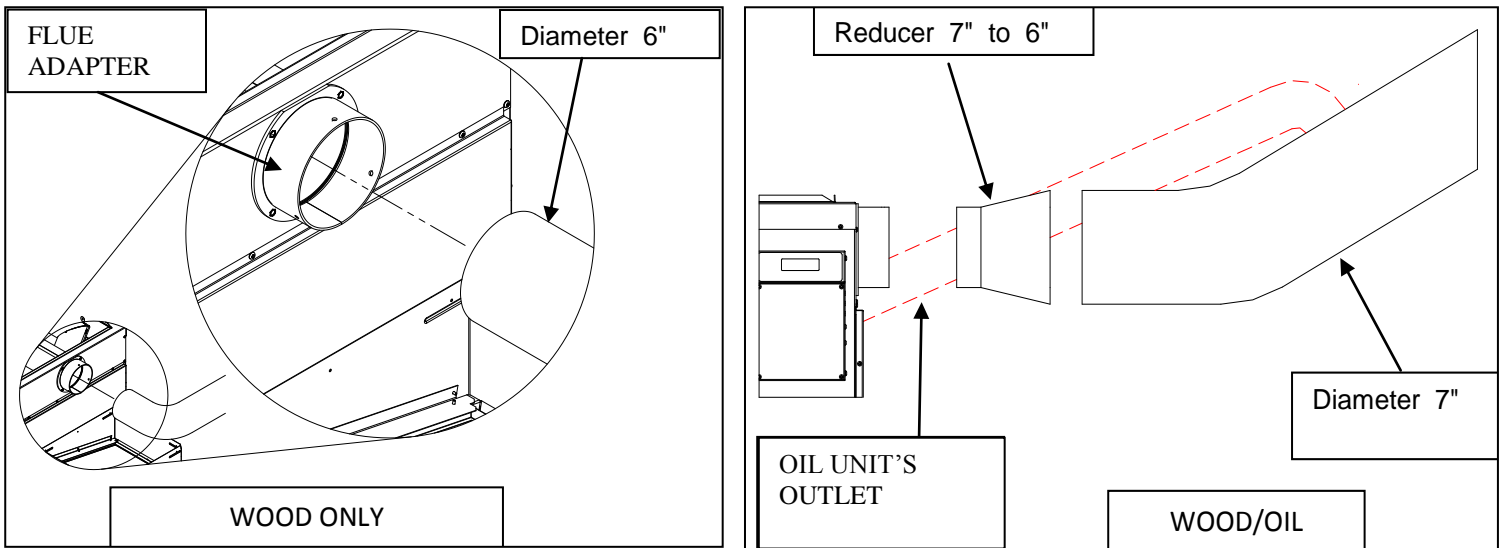

For a proper installation, follow the advice below:

1. All the exhaust pipe joints must be secured with three screws. **Make sure that each screw goes through the inner wall of both connectors (male and female).** See pictures below showing a male-female coupling.

PROPER INSTALLATION



IMPROPER INSTALLATION

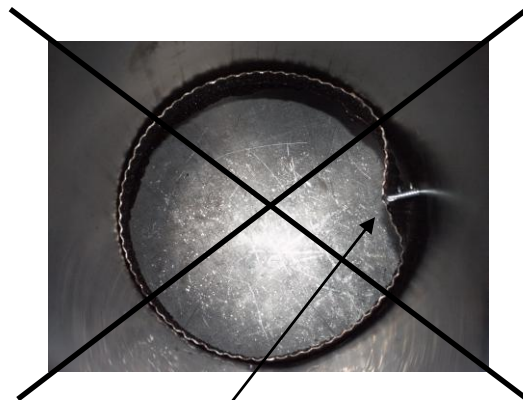

CAUSES RESTRICTION

2. A minimum rise of 1/4" per horizontal foot must be respected.

3.9.1 Damper

If the draft exceeds 0.06 IN.W.C., a barometric damper must be installed. The barometric damper must be adjusted so that the maximum draft measured at the furnace outlet is limited to 0.06 IN.W.C. Please note that a draft higher than 0.06 IN.W.C. will reduce efficiency and could result in an uncontrollable fire. **On the other hand, the minimum draft to be respected is 0.04 IN.W.C. in the evacuation pipe on the solid fuel side, no matter what type of furnace is use (WOOD, WOOD/ELECTRIC, WOOD/OIL, or WOOD/OIL/ELECTRIC).**

3.10 FRESH AIR INTAKE ADAPTER INSTALLATION (OPTIONAL)

When the furnace and the chimney are completely cold, it may be necessary to provide fresh air by opening a door or a window for a few minutes while lighting the fire.

Take note that a house constructed or renovated in order to be airtight may lack the volume of fresh air necessary for the proper combustion of a solid-fuel heating appliance.

In such a case, when starting up the fire, do not operate appliances that evacuate air outside the house, such as:

- Range hood
- Air exchanger
- Clothes dryer
- Bathroom fan
- Ventilated central vacuum system

A fresh air supply may be necessary to prevent solid fuel units from rejecting products of combustion into the house. The indications used to determine if an additional fresh air supply is necessary are not appropriate for all the situations. When in doubt, it is recommended to install a fresh air supply.

A fresh air supply may be needed if:

- Solid fuel units present anomalies, such as irregular draft, smoke return, bad combustion, and/or reversed draft (whether there is combustion or not);
- Existing solid fuel units such as a stove or fireplace release odours, heat badly, cause smoke returns, or reversed draft (whether there is combustion or not);
- The opening of a window, even slightly, in calm weather (windless), eliminates every problem mentioned above ;
- The house is equipped with a tight vapour barrier and adjusted windows, and/or is equipped with an interior air mechanical evacuation device ;
- There is excessive condensation on the windows in winter; and
- The house is equipped with a ventilation system.

If, according to these symptoms or other similar ones, there is insufficient combustion air, it is necessary to ensure an additional combustion air supply.

Additional combustion air can be provided following the following methods, provided that they satisfy chapter 4 of the CSA B365 standard for Canada:

- Direct connection: solid fuel units can be connected directly to a source of new combustion air only if they are certified for this kind of installation, which must respect the manufacturer's instructions. The MAX Caddy can be installed with an optional sealed fresh air kit that has been tested with the unit. Consult your dealer.
- Indirect method: new combustion air can be brought into a pipe located within approximately 300mm (12 inches) of the unit. If the pipe is too close to the furnace, it may interfere with its operation.
- Mechanical ventilation system: if the house is equipped with a ventilation system (air exchanger or heat recovery), the ventilation system may provide sufficient auxiliary air to the solid fuel unit. Otherwise, the owner should be informed that the ventilation system may have to be rebalanced by a ventilation technician after the installation of the solid fuel unit.

NOTE:

It is recommended to install an outside air inlet with a diameter of at least 4 inches in the room where the heating appliance is installed (see drawing below). It is preferable to choose a wall which is not exposed to dominant winds, depending on the conditions surrounding your house.

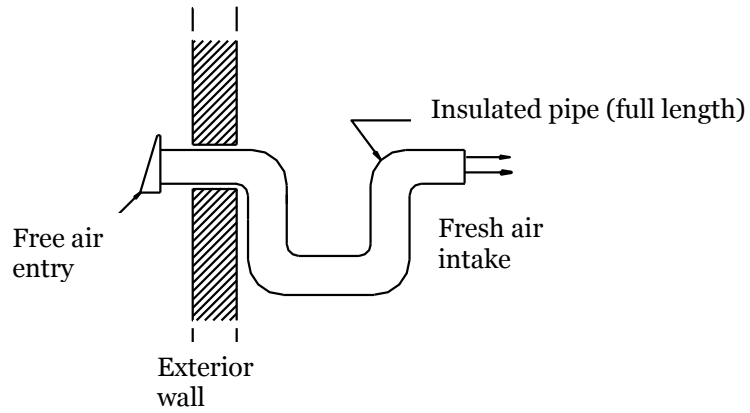

N.B. The owner of the furnace is responsible for the room's air quality in case of negative pressure or temporary negative pressure.

For more information regarding the installation of fresh air intake adapter, refer to the option's manual.

3.11 PARALLEL INSTALLATION

The installation of the Max Caddy with another furnace using the same ductwork is not allowed in Canada. **This type of installation is only allowed in the United States.** Ideally, the maximum BTU input of the existing oil, gas, or electric furnace should be equal or higher than the maximum BTU input of the wood furnace. It is mandatory to respect minimum clearances between the ductwork and combustible material as if the wood furnace was installed as a standalone unit. The ductwork and furnace should be adjusted in order to reach a static pressure of at least 0.20 IN.WC, but not more than 0.50 IN.WC. A back-flow damper should be installed in the plenum. The back-flow damper assures that when either unit is operated by itself, the hot air will flow into the home, and not back through the other furnace. Depending on your installation (see figures examples below), a back-flow damper may be required in each plenum.

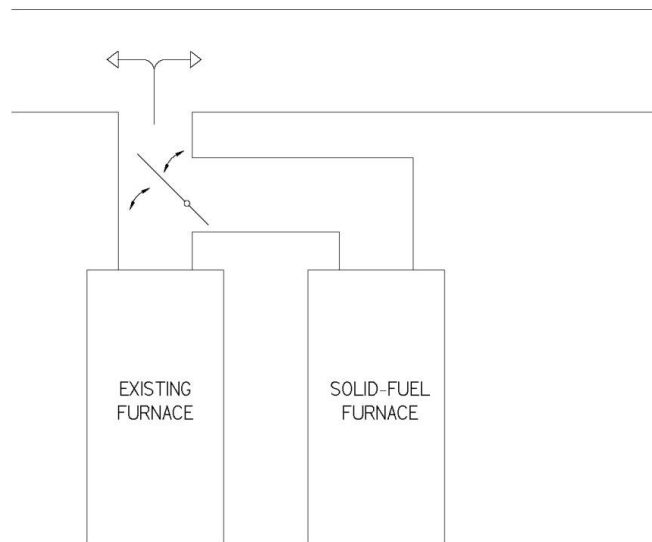
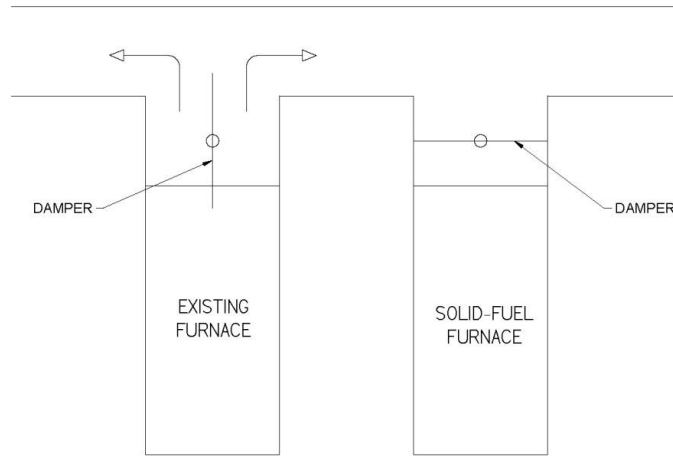

3.12 ELECTRICAL ELEMENT INSTALLATION – WOOD-ELECTRIC MAX CADDY (OPTIONAL)

The high limit control is a manual reset thermostatic sensor that is located inside the electrical unit. The electric unit must be connected as shown on the diagram (see WIRING DIAGRAM). The connections must conform to the diagram.

Electrical connections must conform to the wiring diagram supplied with the option.

The wood / electric combination model uses two thermostats: one thermostat controls the electric heating, and the other one controls the wood heating. With this system, the electric heating has priority over the wood heating. When the thermostat activates the electric heating, the air inlet damper closes down (if opened), the blower starts, and the electric elements are successively activated per block of 5 kW. When the call for electric heating is satisfied, the wood system will take over if the starting point of the wood system thermostat is superior to that of the electric system.

Therefore, under normal wood-electric combination use, you should set the wood system thermostat 2° to 4° higher than the electric system thermostat. The bigger the gap, the more the wood heating will contribute to the overall heating needs.

If the temperature of the electric unit exceeds the high limit, the thermostatic sensor will disengage the elements. To reactivate, press the red “manual reset” button on the thermostatic sensor (L-170 Thermodisc) after finding and fixing the problem that has caused the unit to overheat (static pressure too high, fan breakdown, etc.)

INSIDE VIEW OF THE ELECTRIC ELEMENT

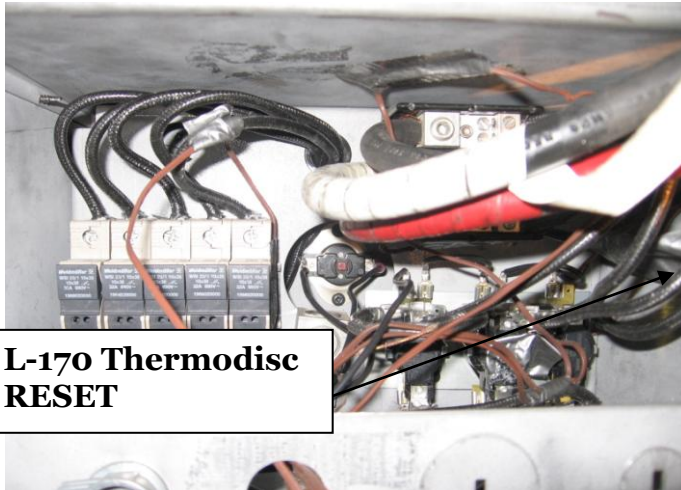

**L-170 Thermodisc
RESET**

**Red button
manual reset**

3.13 THERMOSTAT INSTALLATION

3.13.1 Wood furnace only

The thermostat must be installed on an inside wall and located where it is not likely to be affected by the draft coming from an air outlet. It must be installed at a minimum of 55 inches above the floor.

3.13.2 Combination wood-electric or wood-oil furnace

The combination model uses two thermostats which must be located at the same height from the floor. When the main thermostat (wood) calls for heat and the demand cannot be satisfied by the furnace with wood as a combustible, the option (oil burner or electric unit) will take over and maintain the house at the temperature programmed on the second thermostat (option). If the thermostats use a dry contact, hook-up the main thermostat (wood) to the WOOD MECH port on the PC board and the option's thermostat to the USER MECH port. If the thermostats send a 24 volt signal to the appliance, hook-up the main thermostat (wood) to the WOOD 24V port on the PC board and the option's thermostat to the USER 24V port. For more information regarding the wiring connections, refer to the diagrams in section 7.

3.13.3 Trio furnace (wood-oil-electric or wood-electric-oil)

The trio model also uses two thermostats which must be located at the same height from the floor. When the main thermostat (wood) calls for heat and the demand cannot be satisfied by the furnace with wood as a combustible, the first option will take over and maintain the house at the temperature programmed on the second thermostat (option). Should the first option be unable to satisfy the call for heat, the second option will take over and maintain the house at the temperature programmed on the second thermostat (option). If the thermostats use a dry contact, hook-up the main thermostat (wood) to the WOOD MECH port on the PC board and the option's thermostat to the USER MECH port. If the thermostats send a 24 volt signal to the appliance, hook-up the main thermostat (wood) to the WOOD 24V port on the PC board and the option's thermostat to the USER 24V port. For more information regarding the wiring connections, refer to the diagrams in section 7.

3.14 INSTALLATION OF A DOMESTIC WATER PRE-HEATING SYSTEM (OPTIONAL)

A water heating loop option is also available to pre-heat domestic water using the energy produced by the Max Caddy wood furnace. This water loop kit will be inserted between the wood combustion chamber and the heat exchangers. When heating with wood, the heat from the furnace will pre-heat domestic water that will be stored in a feed tank before entering your existing water heater. Removable panels are installed on both sides of the furnace for quick and easy installation of the loop. A 24 volt solenoid valve must be installed at the inlet of the loop and must be connected to the WATR SOLN terminal on the PC board; when the plenum temperature reaches 140°F, the valve opens to allow water circulation. It closes when the temperature drops below 120°F to prevent overcooling the combustion chamber during low firing rates.

The WATR SOLN terminal may also be used to activate the 24 volt relay of a humidifier installed in the system which, when connected to the PC Board, will be activated and deactivated at the same temperatures as the water solenoid valve (140°F et 120°F). **Complete installation and operation instructions for the hot water loop kit are supplied with the kit and can be downloaded from the PSG web site at www.psg-distribution.com.**

3.15 INSTALLATION OF AN AIR CONDITIONING UNIT

The MAX Caddy wood furnace has been tested with an optional air conditioning unit. If this option is chosen, we recommend an installation as per the graphic provided below. This installation will provide the most efficient and safe operation of the air conditioning unit using the distribution blower of the MAX Caddy furnace during summer. In order to complete the installation of an air conditioning unit, the main thermostat must be a "heat/cool" type. Furthermore, the PC board of the furnace must be in a COOL mode and the desired distribution blower speed must be programmed (see MODES section for complete instructions). It must be noted that upon thermostatic demand for cooling, the distribution blower will start immediately.

The capacity and characteristics of the air conditioning unit that has been tested with the MAX Caddy are stated below. The use of another brand with similar capacity and characteristics is adequate.

Condenser brand: Goodman GSX13048
Capacity: 4 ton
Coil type: Type A, CAUF uncased indoor coil.

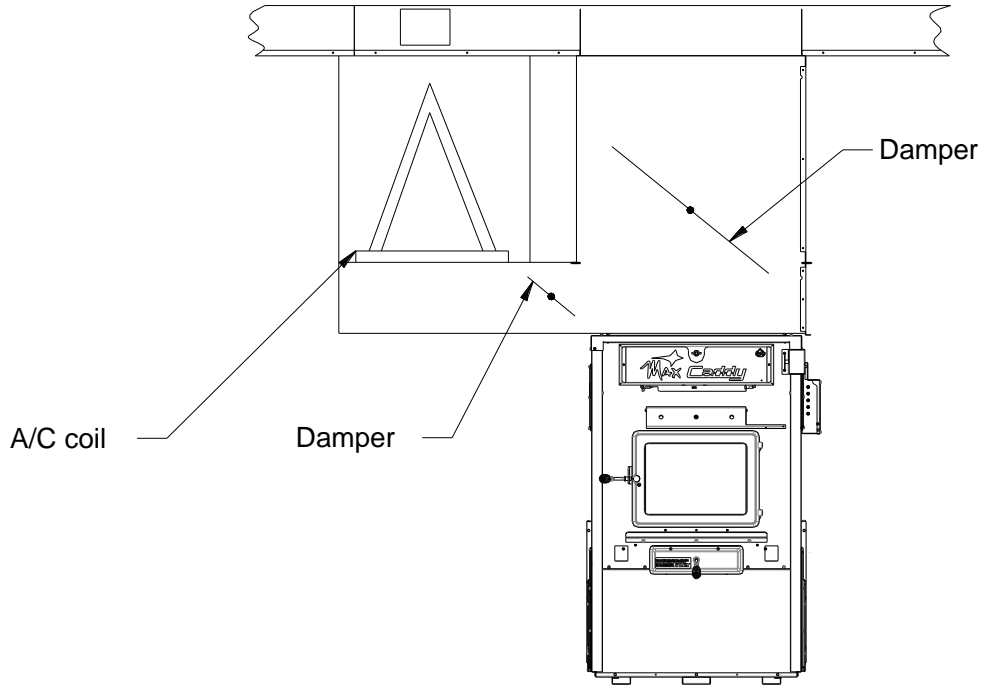

Recommended Installation

3.16 OIL BURNER INSTALLATION – WOOD-OIL MAX CADDY (OPTIONAL)

Refer to section B for the installation and operation instructions for the UH-MAX CADDY wood/oil combination furnace.

4. OPERATING INSTRUCTIONS

4.1 CONTROL SYSTEM

On the Max Caddy furnace, a new electronic control was developed. This system is more polyvalent. All connections are done from the PC board. There are connector ports available for all components and options. Under the HEAT mode, a logic was developed to provide you with the best comfort and efficiency; when you are heating with wood, the distribution blower starts at speed #1 based on a preselected temperature programmed into the PC board (this temperature is called the KIP – *Kick-in Point*). The temperature is read by the RTD probe located inside the hot air plenum. As the temperature continues to rise inside the hot air plenum, the PC board changes the speed of the blower to speed #2. This speed should maintain the most efficient temperature (BEP – *Best Efficiency Point*) inside the hot air plenum. The BEP has been set at 160F by the manufacturer when wood supplies the energy required for heat. If the optional oil burner or electrical unit provide the heat, the BEP is set at 150F. Whenever the temperature inside the hot air plenum continues to rise above the BEP, the PC board selects a higher speed in order to stabilize the temperature into the ducting system and therefore maintain the BEP.

In the case of the electrical or oil option, the blower starts as soon as that there is a request for heat from the option's thermostat. In other words, for security reasons, the distribution blower does not wait for a minimum temperature to be reached inside the hot air plenum before starting. However, the rest of the logic remains the same. That is, for as long as there is a heat demand, the PC board will vary the distribution blower's speed in order to maintain the BEP inside the hot air plenum.

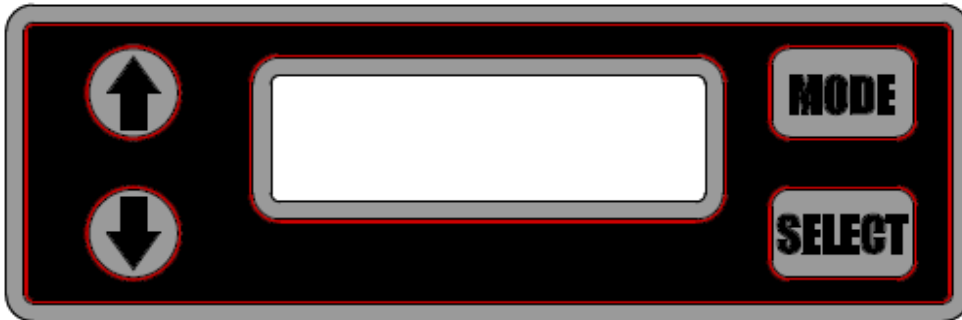

4.2 FIRST USE – GENERAL INFORMATION

The RTD probe reads the temperature inside the hot air plenum and plays the same role as a mechanical fan limit control found on most conventional wood furnaces. The main difference is that the RTD is connected to a PC board. It is an *electronic* fan limit. First, you must configure your PC board. In order to do so, it is important to know which options are installed on your furnace. During the start-up, the PC board will display some information such as the name of the company, the version of the program, as well as a four-digit number corresponding to the default configuration of the furnace.

4.3 FIRST USE - SETTINGS

Using the arrows, you must select the four-digit number corresponding to your installation as per the table below. When your selection is made, push the SELECT button in order to save your setting. Should you need to change this selection, unplug the electrical power and put it back on. Maintain the MODE button pressed for a few seconds. You will then be able to select the option corresponding to your installation.

Table 1 - Configuration

1 1 1 1	Wood only
2 2 2 2	Wood-oil combo
3 3 3 3	Wood-electric combo
4 4 4 4	Trio: wood followed by oil and electricity
5 5 5 5	Trio: wood followed by electricity and oil
6 6 6 6	Bi-energy

4.3.1 The use of the “BI-ENERGY” function

The bi-energy function is used when a local utility company (Hydro-Quebec for instance) offers a bi-energy program under which a preferential rate is given, provided that the appliance is equipped with an electronic control that guarantees the use of a particular source of energy (ex: electricity) based on a given criterion (ex: the outdoor temperature).

When the MAX Caddy is programmed for bi-energy, a temperature sensor (normally open contact) is connected to the PC board (see electric diagram – “BIENERGY” port). The contact remains open for as long as the outside temperature is above a certain value (this reference value is programmed into the system provided by the utility company). As long as the contact remains open, the electrical unit supplies the heat when the wood is not able to satisfy the thermostatic demand. If, however, the outside temperature reaches a level below the reference value, the contact closes and the oil unit is used as the option for heat if the wood is not able to satisfy the thermostatic demand.

4.4 FAN CONTROL

We recommend that the HEAT mode be programmed for the MAX Caddy. Under the HEAT mode, the distribution blower uses various speeds that are controlled by the PC board based on the hot air plenum temperature. The plenum temperature is read by the RTD temperature probe. The manufacturer’s programmed settings should provide the most efficient operation for a majority of installations. The PC board also has a manual mode (“MANU” – consult the MODES section of this manual). Under the manual mode, the MAX Caddy operates as a conventional furnace. That is, the distribution blower starts at the speed programmed in the PC board (one single speed) based on only one temperature point read by the RTD probe inside the hot air plenum.

The adjustment of all controls must be performed by a qualified technician. In order to obtain a continuous air circulation during summer, you simply need to change the PC board mode to “CIRC”. To do so, consult the MODES section of this manual.

It is not recommended to let the blower run on the continuous mode when heating with wood since the wood furnace must reach a certain temperature before the blower starts in order to operate efficiently.

4.5 MODES, OPTIONS, AND PROGRAMMING

Your PC board is equipped with four operating modes : HEAT (automatic heating), COOL (air conditioning), CIRC (recirculation), and MANU (manual heating). You can pass from one mode to the other by pressing on the arrows buttons. For each mode, some selections are available. A definition is provided below (see : “*The Selections*”).

4.5.1 The speeds

Your furnace is equipped with a 4-speed blower. Using the PC board, we have created 6 functional speeds. Refer to Table 2 below for the various speed configurations.

Table 2 – The Speeds

Speed	Corresponding data	CFM*	Static pressure
1	Blower speed #1 using 98V	600	0.2" H ₂ O
2	Blower speed #1 using 115V	760	0.2" H ₂ O
3	Blower speed #2 using 98V	840	0.2" H ₂ O
4	Blower speed #2 using 115V	950	0.2" H ₂ O
5	Blower speed #3 using 115V	1150	0.2" H ₂ O
6	Blower speed #4 using 115V	1260	0.2" H ₂ O

*These results were measured at exit of plenum during laboratory tests. Results may vary depending of the configuration and installation.

4.5.2 System Balancing

It is important to call upon a professional installer for the installation of the furnace and the ducting system configuration. Certain check-ups must be performed and certain rules must be respected in order not to damage the blower. When all components are installed on the furnace and the ducting system is connected to the various rooms of the house, you must balance the ducting system. In order to do so, start the furnace blower by selecting the recirculation mode (CIRC). Then, in the FAN section, use the arrows to select speed #4 (refer to Table 2). It is important to respect the velocity in the main duct, the secondary ducts, as well as the velocity at the room outlets. The static pressure of your system must be adjusted to at least 0.2 IN.W.C. and must not exceed 0.5 IN.W.C. Finally, make sure that you never exceed the maximum blower motor full load amperage.

4.5.3 HEAT Mode (automatic heating)

Operation

When the temperature in your house is below the value at which your wall thermostat is programmed, a signal is sent to your furnace through the PC board, activating the motorized damper located in front of the furnace and thus allowing more oxygen to the fire. The RTD temperature probe, located inside the hot air plenum of your furnace, reads the plenum temperature continuously. When the temperature reaches the start-up value selected by the user (KIP – *Kick-in Point*), the distribution blower starts functioning at the minimum speed. Thereafter, the blower increments its speed until it reaches the best efficiency point (BEP) determined by the manufacturer. If the temperature inside the hot air plenum exceeds the limit determined by the manufacturer, the blower automatically selects the maximal speed and the motorized damper closes in order to slow down combustion. When the temperature returns to a safe level, the blower speed gradually returns to the speed required to maintain the BEP.

Programming

Make sure that your wall thermostat is well connected to the PC board. Make sure that the right port has been selected based on the type of thermostat (e.g. 24VAC or Millivolt).

In the MODE menu, select HEAT by pushing the SELECT button. Then, using the arrows buttons, choose from the different selections: KIP, TEMP, or UNIT. Consult the “**Selections**” section in order to obtain a complete definition of the terms KIP, TEMP, and UNIT.

When your choice is made, press SELECT. Then, use the arrows to make the appropriate adjustment. Press SELECT to memorize your adjustment. To change the selection (KIP, TEMP, or UNIT) push an arrow button. To go back to the main menu (HEAT, COOL, CIRC, MANU), push on the MODE button. After two minutes of inactivity on the keyboard, the display will shut itself off.

4.5.4 COOL Mode (air conditioning)

Operation

If an air conditioning unit is installed, the PC board will have to be connected to a dual-function wall thermostat (e.g. “heat/cool”) in order to synchronize the start of the furnace blower with the start of the air conditioning condenser. Upon receiving the wall thermostat’s signal, the furnace blower will start functioning at the speed selected by the user.

Programming

Make sure that your wall thermostat is well connected to the PC board. Make sure that the right port has been selected based on the type of thermostat (e.g. 24VAC or Millivolt).

In the MODE menu, select COOL by pushing the SELECT button. Then, using the arrows buttons, choose from the different selections: TEMP, UNIT, or FAN. Consult the “**Selections**” section in order to obtain a complete definition of the terms TEMP, UNIT, and FAN.

When your choice is made, press SELECT. Then, use the arrows to make the appropriate adjustment. Press SELECT to memorize your adjustment. To change the selection (TEMP, UNIT, or FAN) push an arrow button. To go back to the main menu (HEAT, COOL, CIRC, MANU), push on the MODE button. After two minutes of inactivity on the keyboard, the display will shut itself off.

4.5.5 CIRC (air circulation)

Operation

This mode is used to circulate air during summer. Thus you will benefit from your ducting system to circulate fresh air from your basement throughout the house.

Programming

In the MODE menu, select CIRC by pushing the SELECT button. Then, using the arrows buttons, choose from the different selections: TEMP, UNIT, or FAN. Consult the “**Selections**” section in order to obtain a complete definition of the terms TEMP, UNIT, and FAN.

When your choice is made, press SELECT. Then, use the arrows to make the appropriate adjustment. Press SELECT to memorize your adjustment. To change the selection (TEMP, UNIT, or FAN) push an arrow button. To go back to the main menu (HEAT, COOL, CIRC, MANU), push on the MODE button. After two minutes of inactivity on the keyboard, the display will shut itself off.

4.5.6 MANU (manual heating)

Operation

The mode allows you to run your system manually without taking into account the blower variation around the BEP (*Best Efficiency Point*). Therefore, you will simply have to select the KIP (i.e. *Kick-in Point* - the hot air plenum temperature at which the blower will start), as well as the blower speed based on your system's static pressure. When the temperature in your house will go below the value at which your wall thermostat is programmed, a signal will be sent to your furnace through the PC board, activating the motorized damper located in front of the furnace and allowing more oxygen to the fire. The RTD (temperature sensor), located in the hot air plenum of your furnace, will read the plenum temperature. When the temperature reaches the start-up value selected by the user (KIP), the blower will start functioning at the speed selected by the user. If the temperature exceeds the limit determined by the manufacturer, the blower will automatically select the maximal speed and the front air damper will close in order to slow down combustion. When the temperature returns to a safe level, the blower will return to the speed selected by the user.

Programming

Make sure that your wall thermostat is well connected to the PC board. Make sure that the right port has been selected based on the type of thermostat (e.g. 24VAC or Millivolt).

In the MODE menu, select MANU by pushing the SELECT button. Then, using the arrows buttons, choose from the different selections: KIP, TEMP, UNIT, or FAN. Consult the “**Selections**” section in order to obtain a complete definition of the terms KIP, TEMP, UNIT, and FAN.

When your choice is made, press SELECT. Then, use the arrows to make the appropriate adjustment. Press SELECT to memorize your adjustment. To change the selection (KIP, TEMP, UNIT, or FAN) push an arrow

button. To go back to the main menu (HEAT, COOL, CIRC, MANU), push on the MODE button. After two minutes of inactivity on the keyboard, the display will shut itself off.

4.5.7 The Selections

KIP (Kick-in Point - start-up temperature of the furnace blower)

Using the arrows, increase or decrease the temperature at which the furnace distribution blower will start functioning. You can adjust the temperature between 107°F (42°C) à 132°F (56°C) . After two minutes of inactivity on the keyboard, the display will shut itself off. The KIP must be programmed if the furnace is operated under the HEAT or MANU modes.

TEMP (Temperature)

By pushing the arrows, you will see the current temperature inside the main hot air plenum of your furnace. After two minutes of inactivity on the keyboard, the display will shut itself off. The TEMP selection has no impact on the operation of the furnace. It is offered as a practical way for an installer or a technician to quickly obtain the temperature inside the hot air plenum under the HEAT or MANU modes if a problem arises and the temperature must be known in order to trouble shoot the furnace.

UNIT (measuring unit)

By pushing the arrows, you will select the measuring unit that you wish to use (Fahrenheit or Celsius). Thereafter, temperatures will be displayed according to your selection. After two minutes of inactivity on the keyboard, the display will shut itself off. The UNIT selection has no impact on the operation of the furnace. It is simply a preference chosen by the technician or the user of the product..

FAN (blower speed)

Using the arrows, increase or decrease the blower speed. You can choose from six preselected speeds. This selection is very important for the modes COOL, MANU, or CIRC. There is a choice of 6 different speeds. Under the COOL mode, the speed selected is the speed at which the distribution blower will work when a cooling demand will be sent by the thermostat. Under the MANU mode, it is the speed at which the distribution blower will work when a heating demand will be sent by the thermostat and that the hot air plenum will have reached its kick-in temperature (KIP). Under the CIRC mode, it is the speed at which the distribution blower will run to circulate the air inside the house during summer. The CIRC mode will also be used by the technician to manually select speed #4 in order to balance the system upon installation of the furnace.

Note: The FAN selection is not necessary under the HEAT mode because it is the PC board that automatically chooses the speed at which the distribution blower runs in order to maintain the BEP inside the hot air plenum.

4.6 LIGHTING

1. Open the furnace door

Note: If there is already a bed of coals in the firebox, go to pre-heating.

2. Place one or two dry kindlings at the front of the furnace.

3. Place newspaper strips on top of the kindlings.

4. Cover the newspaper with more kindlings and small pieces of dry wood.

5. Add newspaper strips, then light the fire as low as possible and leave the door 1/2" (13 mm) opened. If you fail lighting the fire, you might experience a back draft through the air inlets.

4.7 PREHEATING

1. Once the kindling is well ignited or the coals revived, put 2 or 3 fire logs in such a way that the flames can interlace between the logs. Then, close the door. It is important to respect these loading sequences so that the wood will burn from the front to the back of the furnace.
2. Wait 15 to 20 minutes, then proceed with loading the furnace.

4.8 HEATING

1. When loading the furnace, lower the kindled pieces of wood and place them at the center of the combustion chamber before adding new logs.
2. Do not overload. Air must circulate freely in the upper part of the combustion chamber in order to obtain an efficient operation of the appliance (secondary burn). Please note that a small hot fire will produce much less residues than a large, smouldering one.

IMPORTANT: DURING THE HEATING PROCESS, REMOVE THE ASHES AND WOOD THAT COULD OBSTRUCT THE 1/4" (6.4 mm) HOLE (PILOT) LOCATED BELOW THE DOOR, INSIDE THE FURNACE'S COMBUSTION CHAMBER.

PROCEDURE TO OPEN THE LOADING DOOR

TO MINIMIZE THE RISK OF SMOKE SPILLAGE, OPEN THE DOOR 1" AND WAIT ABOUT 10 SECONDS BEFORE OPENING IT COMPLETELY. THE PURPOSE IS TO STABILIZE THE PRESSURE INSIDE THE FURNACE.

4.9 EARLY SIGNS OF AN OVERFIRED FURNACE:

1. Roaring fire.
2. Chimney connector is glowing red.
3. Extreme heat coming from the furnace. If this occurs, **DO NOT OPEN THE DOOR**. Shut-off the air inlet opening completely, and wait until the glow has completely subsided.

ALWAYS KEEP THE DOOR AND THE ASH DRAWER CLOSED
(except for lighting and maintenance).

4.10 WOOD AS HEATING FUEL

We recommend that you burn dry hard wood only. There are two important factors to be considered when choosing a type of wood: the moisture content and the wood density. Hardwood, oak and beech for example, will provide better results because of the high density and minimal tar produced during combustion. It is highly recommended to use wood that has been dried for at least six months. **Do not use coal as heating fuel in this appliance.**

Whenever a high rate of smoke is noticed in the room, you must:

1. Open doors and windows.
2. Make sure the furnace door is closed as well as the damper (if necessary, lower the thermostat starting point or unhook the damper chain and close the barometric draft control manually).
3. When the furnace has cooled down, inspect the chimney to detect obstructions and consult a specialist to determine the cause of the smoke spillage.

4.11 PROLONGED POWER FAILURE

DURING PROLONGED POWER FAILURE, YOU CAN USE YOUR FURNACE. THE DAMPER REMAINS IN CLOSED POSITION AND THE FURNACE FUNCTIONS AT THE MINIMUM BURN RATE. IT IS VERY IMPORTANT YOU ENSURE THE HOLES (1/4" DIAMETER) LOCATED UNDER THE LOADING DOOR INSIDE THE FURNACE'S COMBUSTION CHAMBER ARE FREE TO ENSURE A GOOD PERFORMANCE.

CARBON MONOXYDE IS A LETHAL GAS (ODOURLESS AND COLOURLESS), WHICH YOU MUST BEWARE OF.

4.12 CHIMNEY FIRES

This might occur when the fire gets extremely hot. Burning cardboard, branches, or small pieces of wood can ignite the creosote residue accumulated in the evacuation flue system. The usual signs are:

1. Rumbling.
2. The flue gets extremely hot (red).
3. Flames or sparks are coming out of the chimney.

In case of a chimney fire, call your local fire department immediately and sprinkle the roof around the chimney with water.

Make sure that the furnace door is closed as well as the damper (if necessary, lower the thermostat starting point or release the chain from the damper and close the barometric draft control manually).

If the fire gets uncontrollable due to an improper use or because the draft is too strong, follow the same procedure as in a chimney fire except that you will have to **OPEN** the barometric draft control manually.

LOCAL FIRE DEPARTMENT

Phone number: _____

5. MAINTENANCE

5.1 MAINTENANCE OF THE EXCHANGERS

The flue pipe and the exchangers should be inspected regularly during the burning season. Easy access is provided (without the use of tools): simply unscrew the wing nut on the exchangers access door. See pictures below.

WARNING : THE CLEANING OF THE HEAT EXCHANGERS, OF THE FLUE PIPE, THE CHIMNEY, AND THE EXHAUST BLOWER (IF APPLICABLE), IF NECESSARY, IS PARTICULARLY IMPORTANT AT THE END OF THE WINTER SEASON IN ORDER TO REDUCE CORROSION DURING THE SUMMER MONTHS, CAUSED BY ACCUMULATION OF ASHES.

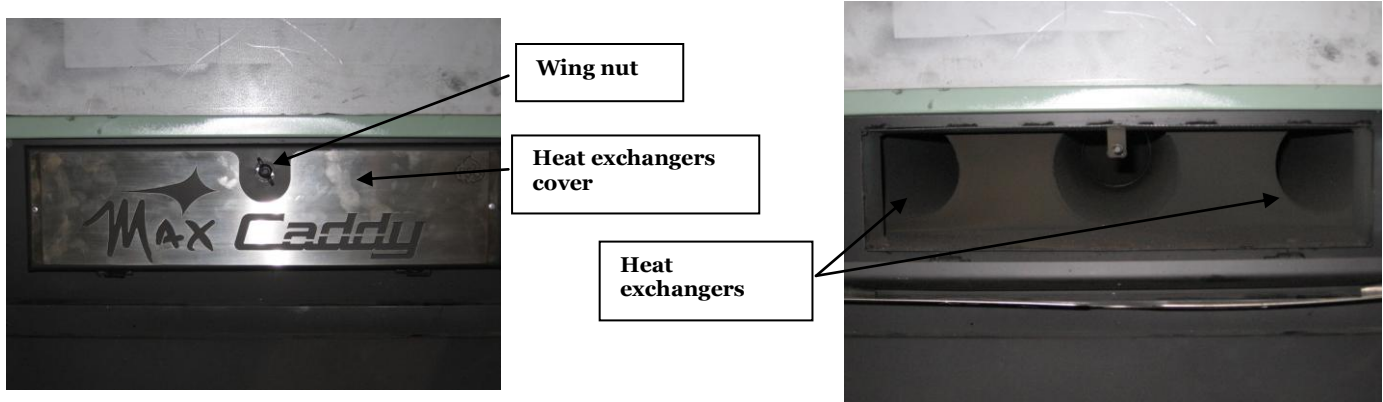

Before cleaning the three exchanger pipes, move the upper vermiculite baffle board of the combustion chamber forward (see drawing on next page). Using the scraper, clean the three exchanger pipes. The accumulated dirt in the lateral exchangers will fall into the combustion chamber; the dirt in the central exchanger will have to be removed from the front or the back of the furnace. Then, ensure that the upper baffle board is free of ashes. **Do not forget to push the upper baffle board back to it's original position.** Finally, close the exchanger access door.

MAX CADDY SECTION VIEW

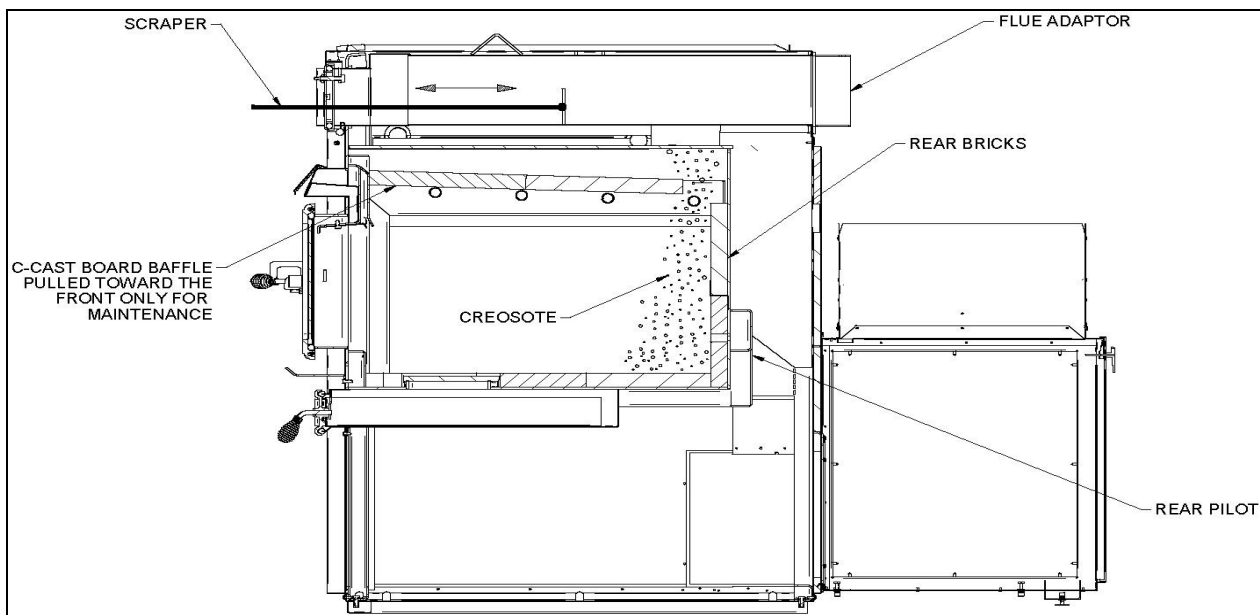

5.2 CHIMNEY MAINTENANCE

The most efficient method to sweep the chimney is using a hard brush. Brush downwards so soot and creosote residues will come off the inner surface and fall at the bottom of the chimney where they can be removed easily.

The chimney must be checked regularly and if creosote has accumulated, it must be removed without delay.

Smoke flue inspection

- The smoke flue (connector) should be inspected regularly during the heating season.
- If possible, the smoke flue should be dismantled and cleaned.
- The flue should be inspected for possible damage.
- If it is in good condition, put the flue back in place; otherwise, it must be replaced.
- REGULARLY, EXAMINE THE FLUE PIPES, THE JOINTS, AND THE SEALING TRIMS TO ENSURE THAT THE SMOKE AND THE COMBUSTION GASES ARE NOT TRANSPORTED INTO THE AIR DUCTING SYSTEM.
- Use only wood as a combustible.
- Seasoned hard wood logs 18" to 22" long are recommended as combustible.

5.3 MAINTENANCE OF THE BLOWER MOTOR

The two motor bearings must be lubricated once a year using non detergent SAE 20 oil (Marathon motor only).

DO NOT OVERLUBRICATE

5.4 FILTERS

The furnace must not be operated without filters. In order to efficiently and safely operate a slow combustion heating system, you have to ensure a regular maintenance. This means that the chimney, the joints and the flue must be kept in good condition and the air filters must be replaced regularly; use the same size and same type as the original filters. High efficiency 2-ply, 3-ply, or 4-ply filters are recommended.

Filters dimensions

Max Caddy: 16" x 20" filters

5.5 DOOR GASKET MAINTENANCE

It is important to maintain the door gasket in good condition. After a while, the gasket might sag; a door adjustment may then be required. If the door adjustment is not sufficient, replace the door gasket with a genuine one.

Door adjustment procedure:

1. Unscrew completely the locking pin (see picture below).

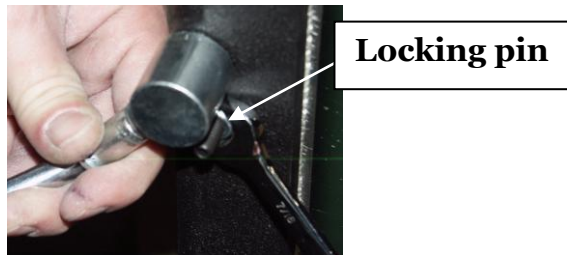

2. To increase the pressure of the door on the gasket, turn the handle counter clockwise; to decrease the pressure of the door on the gasket, turn the handle clockwise until desired pressure is attained.
3. Then, screw back the locking pin about 1/4" deep and make sure you lock it in place with the nut.

6. REPLACEMENT PARTS

Your PSG furnace is designed to burn clean and requires little maintenance. It is recommended to conduct a visual inspection at least once a month to uncover any damage to the unit. Any defect must be repaired without delay using genuine PSG replacement parts. You can find a complete list of replacement parts in our website at www.psg-distribution.com.

6.1 DOOR GLASS

- Inspect the glass regularly to detect any glass failure. If you find any defect, stop using the wood furnace immediately. Never operate a wood furnace with a broken glass.
- If you have to change your door glass, you must use Pyroceram 3/16" (5mm) thick. Use genuine parts sold by a PSG authorized dealer.
- To replace the glass, remove the screws that hold the glass retainers in place. Removed these retainers and replace the defective glass; the glass gasket should be replaced at the same time. To put back in place, reverse the procedure.
- Do not use abrasive cleanser. Special cleansers for wood fireplaces glass are available in any good hardware store or specialty hearth retailer.
- Clean glass **ONLY** when the unit has cooled down.

6.2 GASKET

We recommend replacing the gasket that seals the door once a year, in order to maintain a good control of the combustion for maximum efficiency and security. To replace your door gasket, remove the old gasket and adhesive. Clean the surface thoroughly, apply a high-temp adhesive/silicone (650°F) sold for that particular use, and put the new gasket onto the door. Wait for at least 4 hours before lighting your furnace.

7. GENERAL ELECTRIC DIAGRAM WITH BECKETT OIL BURNER

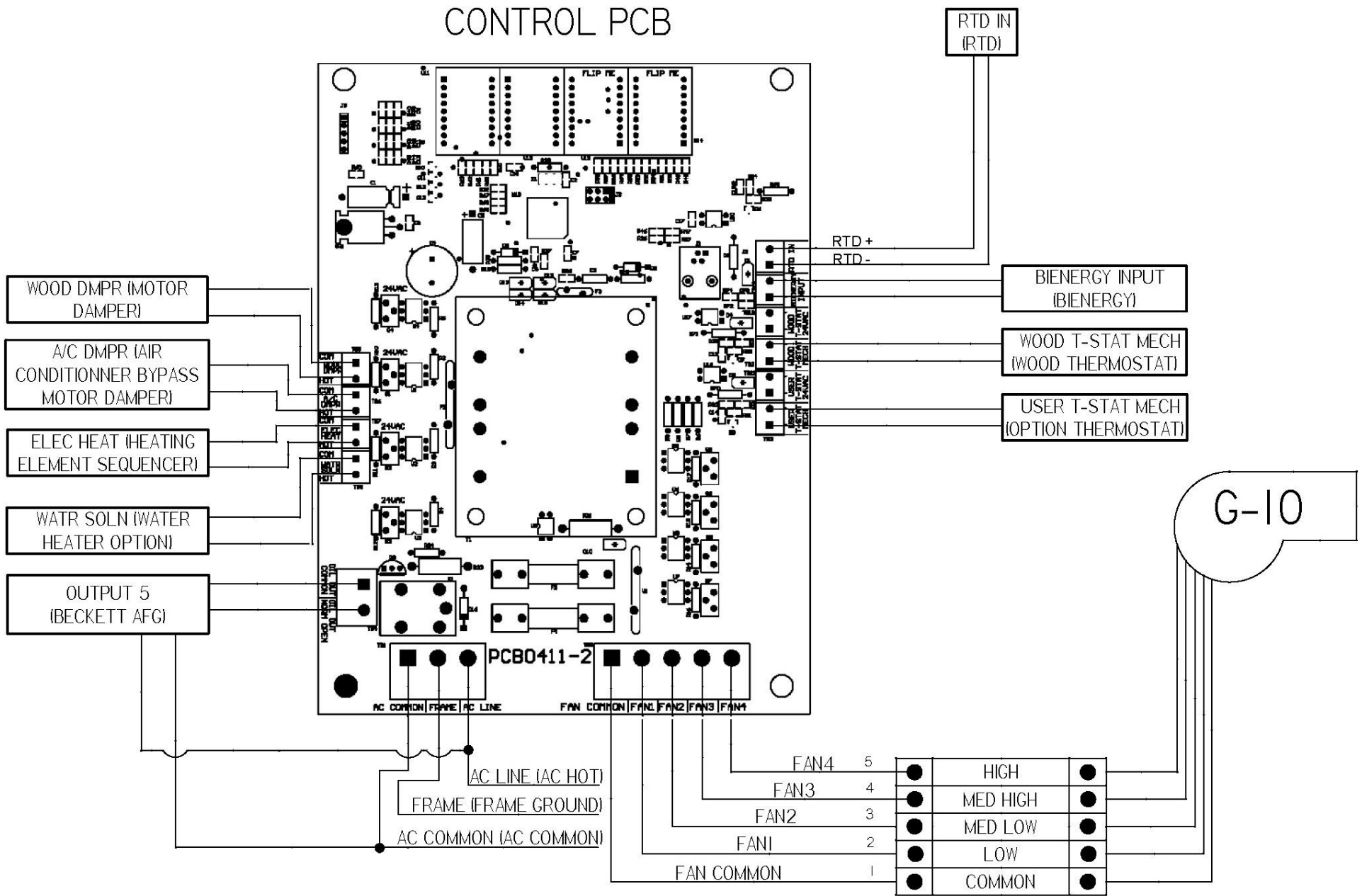

8. GENERAL ELECTRIC DIAGRAM WITH RIELLO OIL BURNER

CONTROL PCB

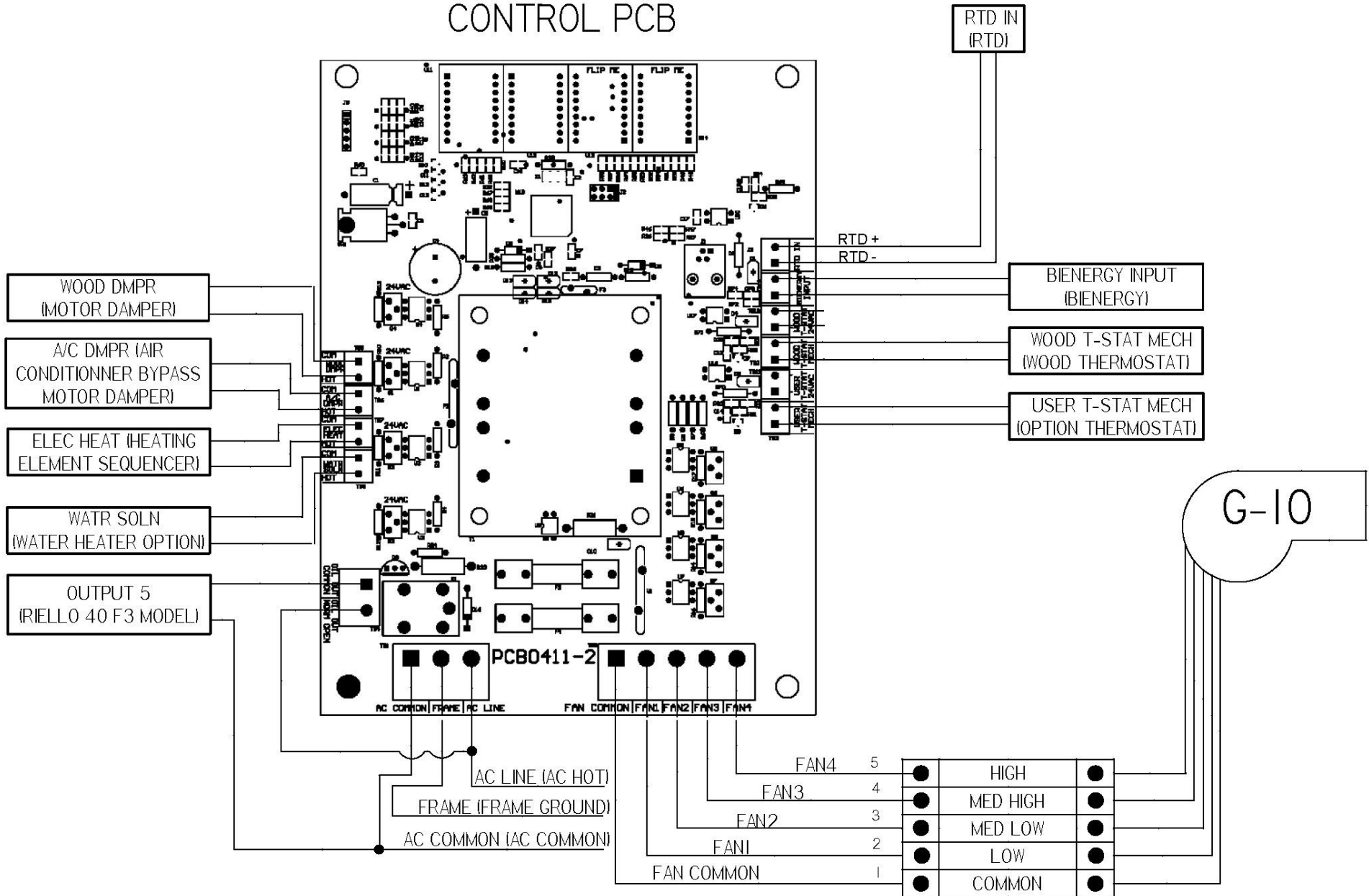

9. ELECTRIC DIAGRAM WITH OPTIONAL ELECTRICAL ELEMENT

MAX CADDY WOOD/ELECTRIC COMBINATION FURNACE

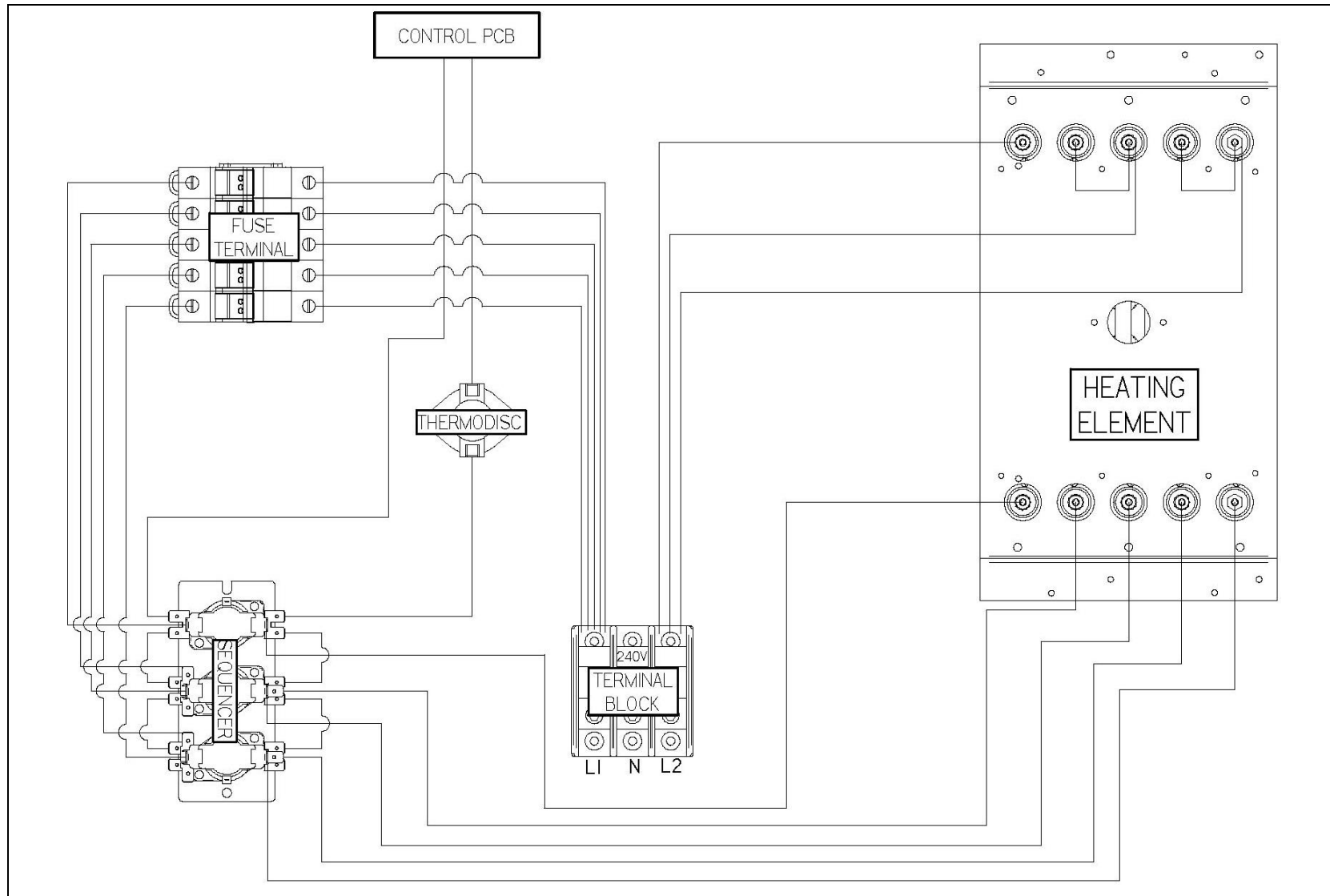

10. MAX CADDY TECHNICAL DATA

	MAX CADDY		
A	57"		
B	29 3/4"		
C	48 3/4"		
D	18 X 20"		
E	32 1/4"		
F	25 1/2"		
G	45"		
FLUE PIPE	6" or 7"*		
WEIGHT	650 lbs		

* Reducer required

10.1 GENERAL TECHNICAL DATA

MODEL	DIRECT DRIVE			THEORETICAL FLOW (CFM)	TEMP VAR. (° F)	BTU INPUT (WOOD)	STATIC PRESSURE		FILTER (1)
	FAN	MOTOR	SPEED				MIN.	MAX.	
							IN.W.C.		
MAX CADDY	G-10	1/2HP	4	1780	100	180,000	0,2	0,5	16" x 20" X 1"

10.2 TECHNICAL DATA – ELECTRICAL ELEMENT

MODEL	OUTPUT (CFM)	TEMP. VAR. (° F)	BTU/HR	AMPS TOTAL	BREAKER REQUIRED	FEEDER GAUGE	VOLTAGE SINGLE PHASE	ELEMENTS QTY
20 kW	1800	75	68,240	85	125 amps	3	120/240	4 x 5 kW
25 kW	1800	85	85,325	100	150 amps	2	120/240	5 x 5 kW
WOOD	1800	100	180,000	5	15 amps	14	120	N/A

11. MAX CADDY BRICKS LAYOUT

Item	DESCRIPTION	QTY
1	BRICK 3 5/8" X 8"	1
2	BRICK 3 1/2" X 5" (CUT)	2
3	BRICK 4" X 6"	3
4	BRICK 4" X 8" (SPECIAL)	1
5	BRICK 4" X 9" (YELLOW)	5
6	BRICK 4" X 8 7/8" (SPECIAL)	1
7	BRICK 4" X 8 1/4" X 1 1/4"	20
8	BRICK 6" X 7 1/2"	2
9	BRICK 6" X 8"	4
10	DRILLED BRICK	3
11	C-CAST BOARD BAFFLE 19 3/4" X 11 3/8" X 1 1/4"	2
12	12" X 7" PSG ASH GRATE	1
13	BRICK HOLDER	2

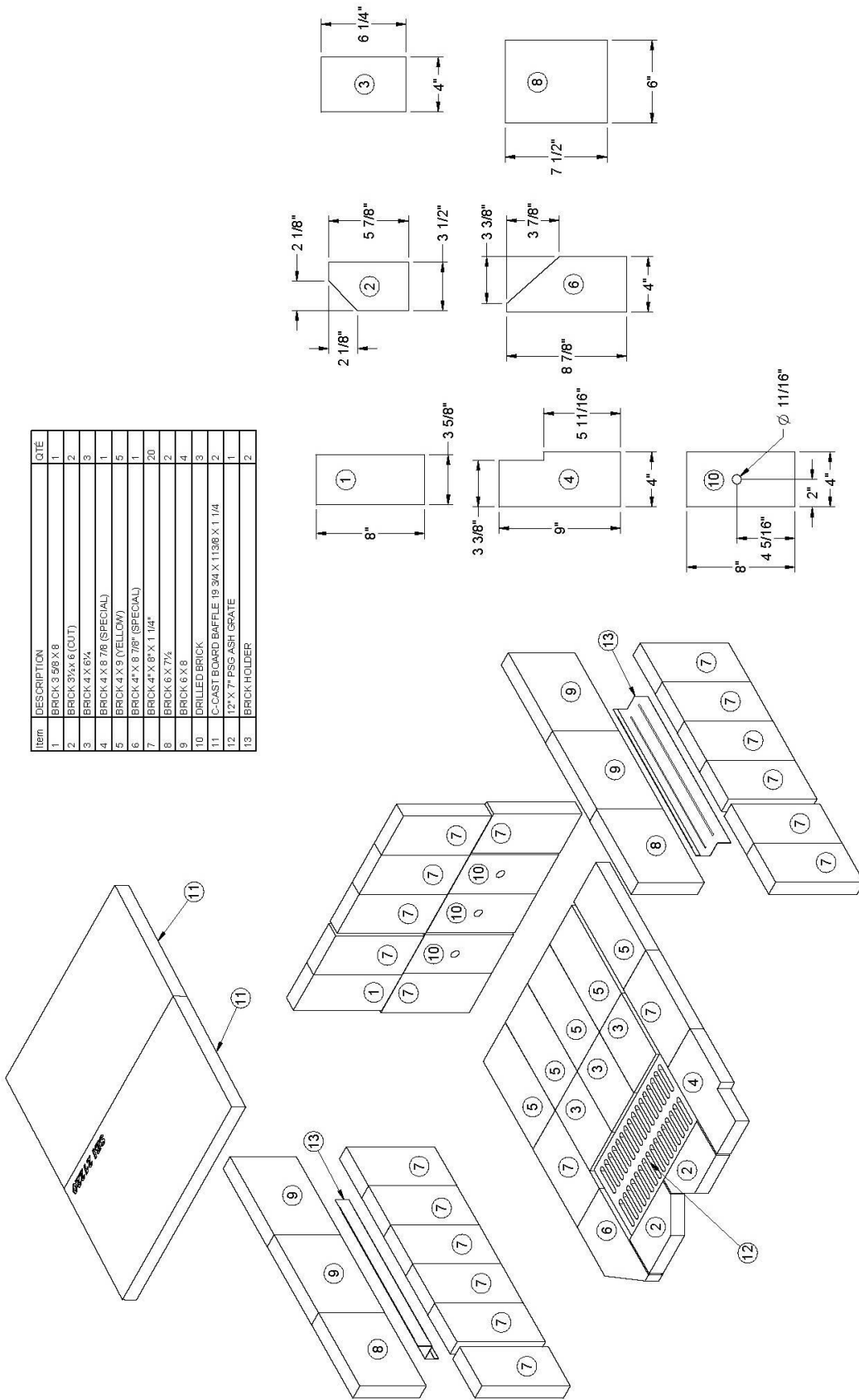

12. TROUBLE SHOOTING

PROBLEM	CAUSES	SOLUTIONS
Heating inefficient during the first combustions. Lack of draft.	Improper adjustment of the barometric damper (opened too wide). Chimney flue restriction (too long, 90° elbows)	Adjust the damper, minimize the chimney length and use 45° elbows.
Furnace heats well, warm air plenum is very hot but there is not much heat coming out in the room.	Improper installation of the ducts, unbalanced system (too many warm air outlets and not enough cold air inlets).	Reinstall the ducts correctly. Respect the minimum static pressure of 0.20 IN.W.C.
Furnace consumes a lot of wood.	The thermostat which controls the damper is continuously activated and is too close to a source of cold air. Damper not properly adjusted. House not insulated enough. Ash drawer is not tightly closed. Furnace too small for the surface to be heated. Unbalanced ventilation system, very little heat where the thermostat is located.	Relocate the thermostat. Adjust the chain that links the damper to the servo-motor. Rebalance the ventilation system in order to increase the air flow in the room where the thermostat is located.
Fan start-up is too slow.	Fan "ON" setting too high. Return air is too cold (temperature lower than 65 degrees). RTD not well located in the warm air plenum.	Lower the temperature starting point. Usually, start-up temperature can be adjusted on the PC board between 125 and 150 degrees F. Reduce the fresh air flow.
A lot of creosote, moderate heat output.	Wet wood, lack of draft. Barometric damper not properly adjusted. Soot-up chimney.	Use dry wood. Adjust the barometric damper. Clean the chimney flue and the furnace exchangers.
Furnace heats a lot but the warm air plenum does not get hot.	Wet wood or low grade wood. Too much cold air return for the hot air ducts. Unbalanced ventilation system.	Use dry wood. Reinstall the ventilation system correctly.

IMPORTANT NOTE

FOR THE INSTALLATION OF A CENTRAL HEATING SYSTEM, IT IS HIGHLY RECOMMENDED TO CONSULT A HEATING SYSTEM VENTILATION SPECIALIST.

SECTION B

WOOD/OIL COMBINATION FURNACE

**INSTALLATION
AND OPERATION INSTRUCTIONS
FOR UH-MAX CADDY WOOD/OIL
COMBINATION FURNACE**

**READ THIS MANUAL THOROUGHLY
BEFORE OPERATING THE FURNACE**

CAUTION

EXPLOSION OR FIRE HAZARD. FOR YOUR SAFETY: DO NOT STORE OR USE GASOLINE OR ANY FLAMMABLE LIQUIDS OR VAPORS IN THE VICINITY OF THIS HEATING UNIT.

CAUTION

DO NOT ATTEMPT TO LIGHT THE BURNER WHEN EXCESS OIL HAS ACCUMULATED, WHEN THE APPLIANCE IS FULL OF VAPOR, OR WHEN THE COMBUSTION CHAMBER IS VERY HOT.

**DO NOT BURN WASTE OR PAPER IN THE APPLIANCE.
DO NOT LEAVE PAPER OR ANY COMBUSTIBLE MATERIAL
AROUND THE APPLIANCE.**

**DO NOT TRY TO MODIFY THE UNIT OR ITS COMMANDS –
CALL A TECHNICIAN**

**PLEASE
SAVE**

THIS DOCUMENT!

GENERAL NOTES

This instructions manual treats mainly of the oil burning unit of your wood/oil combination furnace.

For any additional information concerning this wood burning furnace, please consult Section A of this manual.

To obtain the maximum efficiency out of your furnace, follow the advice below regarding the installation and operation of your WOOD/OIL combination furnace.

- Respect the local codes (when in doubt, consult your local dealer).
- Respect the clearances indicated on this instructions manual and make sure that they match those indicated on the appliance's certification label;
- Make sure that your furnace is installed in conformity with the instructions on the certification label;
- All the controls adjustments must be performed by a qualified technician.

THE INSTALLATION OF THE WOOD/OIL COMBINATION FURNACE MUST BE DONE IN ACCORDANCE WITH THE RULES OF THE AUTHORITIES HAVING JURISDICTION AND FOR CANADA, THE CAN/CSA B-139 STANDARD FOR OIL BURNING HEATING APPLIANCES.

This oil burning furnace is not approved for use with combustible heavier than No.2 oil (furnace oil). **DO NOT USE GASOLINE, TRANSMISSION OIL, OR OTHER TYPE OF OIL CONTAINING GASOLINE.**

1. DRAFT AND CHIMNEY

The chimney must be conform to the rules of the authorities having jurisdiction and the CAN/CSA B139 & NFPA 31 standard regarding installation of oil burning heating appliances. The installation of the connecting pipes to the oil unit must be done and approved by a professional.

The barometric damper provided with the appliance must be properly installed on the flue pipe of the oil unit. The purpose of the damper is to limit the draft, if necessary, in the oil unit evacuation pipe.

Since the evacuation pipe of the oil unit is connected to the evacuation pipe of the wood burning furnace, **the minimum draft to be respected at all times in the evacuation pipe of the wood burning side is -0.04 IN.W.C.**

2. OIL TANK AND PIPING

The maximum capacity of the tank must not exceed 200 imperial gallons and the tank must be located at least 7 feet from the burner. Local codes will govern the size of the air inlets and filling openings as well as the type of plugs to be used. 1 1/4" IPS and 2" IPS are usually accepted as minimum dimensions for the air intake pipes and fill pipes, respectively. The oil line to the burner must be a 3/8" outside diameter copper tubing for runs up to 50 feet and 1/2" o.d. for longer runs. A manual shut-off valve and an oil filter shall follow in sequence on the oil line between the oil tank and the burner. The oil line must be buried or protected adequately to avoid any damage.

2.1 BURNER PUMP

The oil burner is easy to install. Use the three screws and nuts to fix the burner on the combustion chamber.

The burner is equipped with a single stage pump. When the pump is connected to a single feeder pipe, a maximum rise of 8 feet is allowed. This height is measured from the tank outlet level to the burner inlet.

When the rise is more than 8 feet and not exceeding 10 feet, a by-pass plug (provided with the burner) must be inserted in the pump and an oil return pipe must be installed. **For more details, see "INSTALLATION INFORMATIONS", Part No. 21844 on the burner pump.**

If the rise is higher than 10 feet, a two stage pump may be required along with an oil return pipe.

3. APPLIANCE INSTALLATION

3.1 LOCATING THE UNIT

Consult Section A of this manual for more details.

N.B. This appliance must be installed in conformity with the instructions on the certification label.

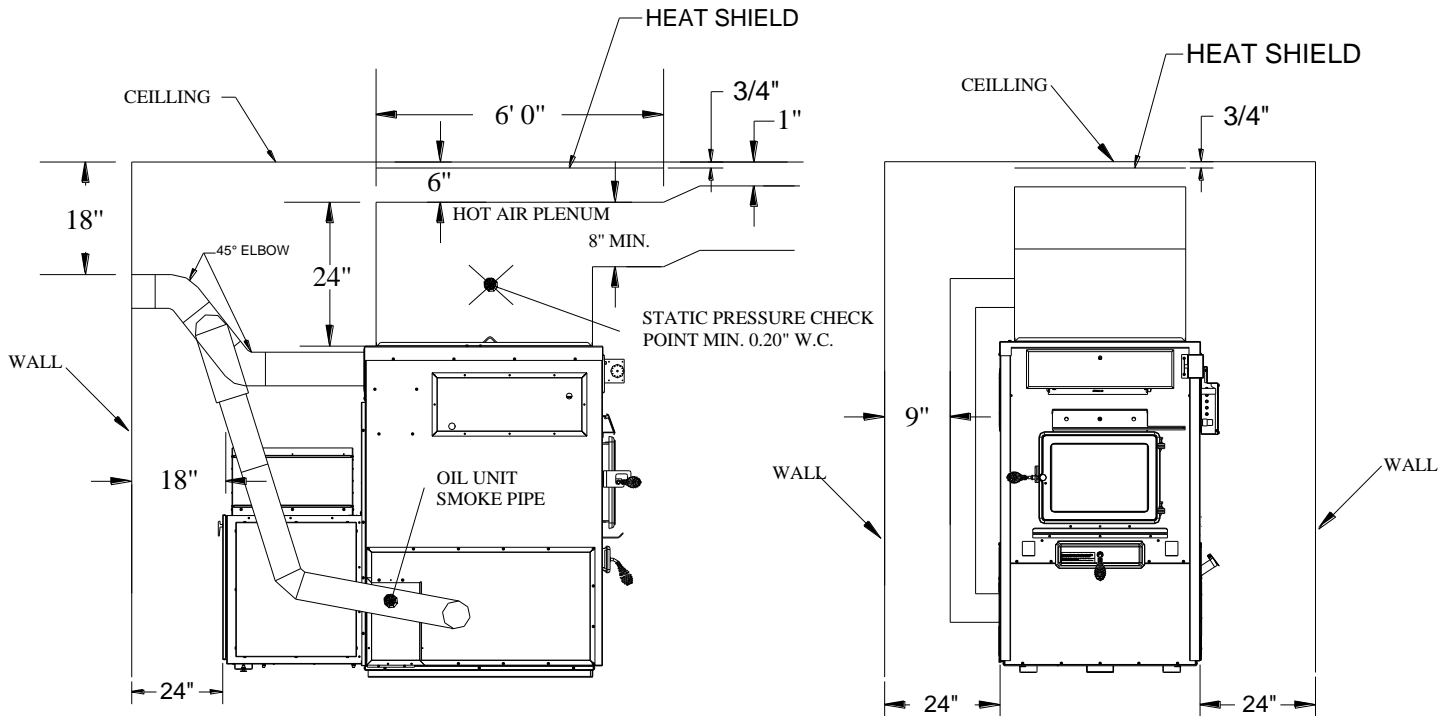

N.B. FOR THE AIR RETURN, RESPECT THE OPENING SURFACE OF THE COLD AIR PLENUM OF THE FURNACE.

3.2 POSITIONING THE APPLIANCE

For a safe and quiet operation, the furnace must be levelled in both directions. Give each "U" shape track an equal support so that the weight is evenly distributed.

3.3 PIPE CONNECTOR AND DAMPER

The pipe connecting the furnace to the chimney must be as short as possible. If a deviation is required, the use of 45° elbows is highly recommended for a better evacuation of the smoke in the chimney of the wood burning furnace. The barometric damper provided with the appliance must be installed on the oil unit evacuation pipe, approximately 24" from the flue outlet of the unit.

TYPE OF FURNACE	(UH) OIL BURNING UNIT FLUE PIPE DIAMETER
PSG/ UH-MAX CADDY	5"

3.4 POSSIBLE INSTALLATIONS

FOR THE WOOD/OIL MAX CADDY

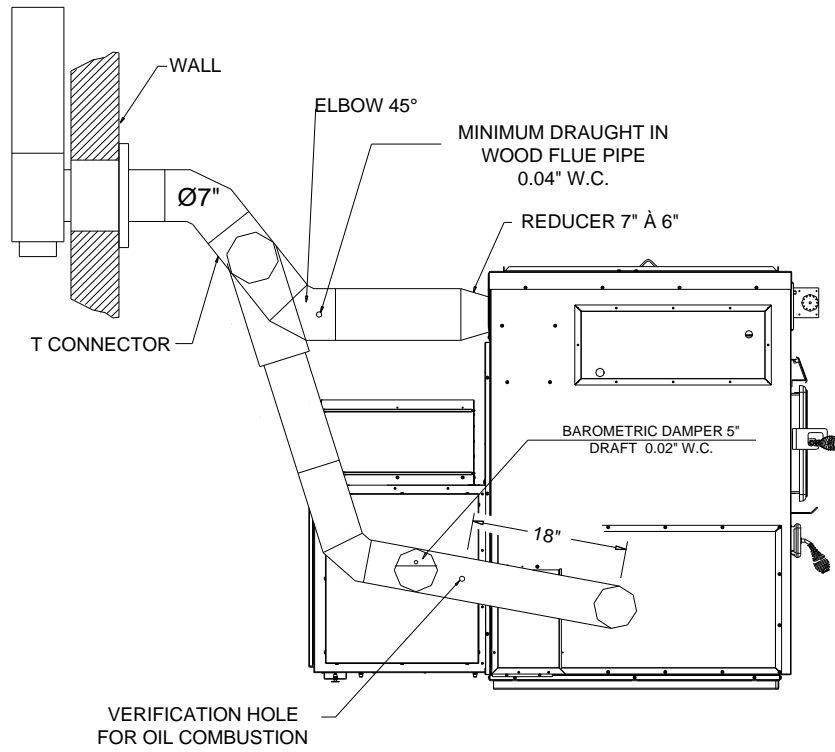

FURNACE TYPE	CHIMNEY PIPE DIAMETER
MAX CADDY	*7"

*REQUIRE A FLUE PIPE REDUCER

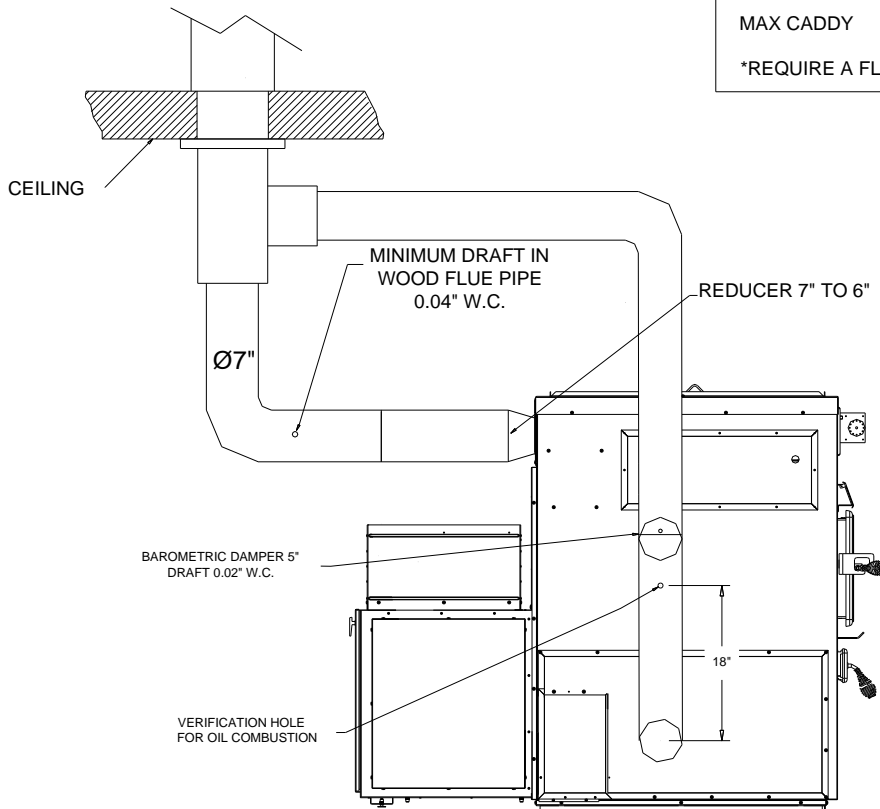

3.5 COMBUSTION AIR

Consult Section A of this manual for more details.

3.6 ELECTRICAL WIRING

The whole wiring from the distribution panel to the heating unit shall comply with the applicable electrical standards and local codes. The unit should be connected to its own 15 amp/120VAC electric circuit. Consult section A of this manual for the electrical wiring diagram using a Beckett or Riello burner.

3.7 THERMOSTAT

Both the wood and oil thermostats must be installed side by side on an interior wall, in a location where they are not affected by the air draft coming from the furnace's blower; they must be level and at least 55 inches above the floor. Consult section A of this manual for more details regarding the thermostats.

3.8 FAN CONTROL

In the case of the oil option, the blower starts once the request for heat is activated by the oil option's thermostat.

The adjustment of all controls must be performed by a qualified technician. For continuous operation of the blower during Summer, the mode must be changed to CIRC on the PC board. Then, the appropriate blower speed must be selected.

It is not recommended to let the blower run on continuous mode when heating with wood since the wood furnace must reach a certain temperature before the blower starts in order to operate efficiently.

3.9 COMBUSTION SAFETY CONTROL

The AFG type oil burner is equipped with an electronic control (# R7184B1032) including a pre-purge function and a new, more durable drive motor.

PRE-PURGE

When there is a call for heat, the burner's fan will run for 15 seconds before the actual ignition takes place to vent the combustion chamber and generate a proper draft. This will result in a smoother ignition of the oil burner.

SAFE OPERATION

If the flame goes out while the burner is running, the CAD cell will detect it; the control will then switch to the "RECYCLE" mode and cut the fuel supply to the burner for 60 seconds. After this delay, the control goes back to "IGNITION" mode. If the flame goes out 3 times in a row, the control will switch to the "LOCKOUT" mode to prevent a continuous cycling of the ignition process, which would cause a premature soot-up of the combustion chamber and smoke pipe. To deactivate the "LOCKOUT" mode, press and hold the reset button of the control for 30 seconds.

A green diagnostic LED on the control has four states:

- On = Flame present
- Off = No flame
- 2 seconds On, 2 seconds Off = "Recycle" mode
- 1/2 second On, 1/2 second Off = "Lockout" mode TEMPORARY SHUT-OFF

By pressing and holding the reset button, the burner will shut-off until the reset button is released. When the button is released, the control will start over at the beginning of the normal cycle.

FOR ADDITIONAL INFORMATIONS ON OPERATION SEQUENCES OF THE BURNER, CONSULT THE BURNER INSTRUCTION MANUAL.

3.10 COMBUSTION ADJUSTMENT AND VERIFICATION

To enjoy the efficiency of our oil burning units, you must respect the following criterion: oil burning units must be connected to flue pipes having at all times a sufficient draft to ensure an efficient and safe operation of unit.

TOOLS REQUIRED:

- DRAFT GAUGE
- SMOKE TESTER
- PUMP PRESSURE GAUGE
- NOZZLE AND ELECTRODES POSITION TESTER
- COMBUSTION TESTER

CHECK LIST:

- SELECTION OF NOZZLE AND HEAD
- NOZZLE / ELECTRODES POSITION IN RELATION TO THE HEAD
- PUMP PRESSURE
- OIL LINE IS BLEED.
- FAN SPEED
- BAROMETRIC DAMPER POSITION

COMBUSTION VERIFICATION PROCEDURE:

- A- DRILL A 9/32" DIAMETER HOLE IN THE EVACUATION PIPE APPROXIMATELY 18" FROM THE OUTLET.
 - B- CLOSE THE DOOR AND THE AIR INTAKE(S) OF THE WOOD BURNING FURNACE.
 - C- LIGHT THE BURNER FOR AT LEAST 10 TO 15 MINUTES.
 - D- OVER THE FIRE DRAFT = 0.01 TO 0.02 IN.W.C. (THE DRAFT OVER THE FIRE MUST BE MEASURED IN THE OPENING OF VISION TUBE'S PULSATION TRAP).
 - E- SMOKE TEST BETWEEN 0 AND 1 ON THE SHELL BACHARACH SCALE (TRACES).
 - F- DRAFT IN THE CHIMNEY = 0.02 IN.W.C.
 - G- PERCENTAGE OF EXCESS AIR = 20 TO 40%, 12% CO₂, 5% O₂.
 - H- AVERAGE EFFICIENCY OF 83% TO 87% BASED ON THE TYPE OF BURNER AND ITS INPUT.
 - I- TIGHTEN ALL THE LOCKING SCREWS AFTER COMPLETING THE FINAL ADJUSTMENT.
- N.B. The barometric damper provided with the appliance must be properly installed on the flue pipe of the oil burning unit. The purpose of the damper is to adjust the draft in the evacuation pipe of the oil burning unit to the recommended level. Since the evacuation pipe of the oil burning unit is connected on the evacuation pipe of the wood burning furnace, the minimum draft to be respected is 0.04 IN.W.C. in the evacuation pipe of the wood burning side, at all times. ***In fact, a barometric damper that would be opened too wide could cause an important loss of draft in the evacuation pipe of the wood burning furnace.***

3.11 ELECTRODES SETTING

The electrodes must be adjusted by a qualified technician. A proper positioning of the electrodes is important to get an efficient lighting of the oil.

ELECTRODE SETTING FOR "F" HEAD

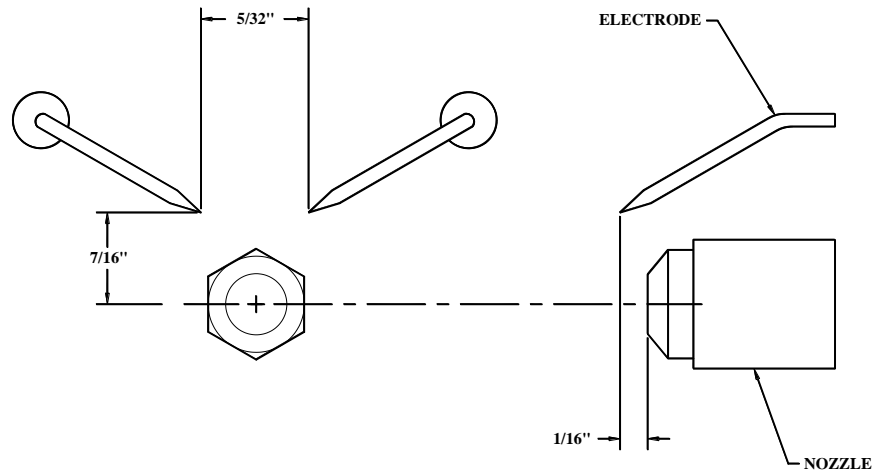

WARNING:

1. REFER TO THE RATING PLATE FOR THE PUMP PRESSURE AND THE NOZZLE TYPE.
2. REFER TO THE OIL BURNER'S INSTRUCTIONS MANUAL FOR DETAILS ON THE PUMP.
3. FOR ELECTRODES SETTING, SEE THE OIL BURNER'S MANUAL.
4. FOR THE START-UP AND ADJUSTMENT OF THE BURNER, SEE THE INSTRUCTIONS MANUAL OF THE BURNER.
5. IN CASE OF BURNER FAILURE, REFER TO THE BURNER MANUAL.

4- APPLIANCE START-UP

The start-up must be performed by a qualified technician. Make sure the installation is completed and the oil tank has been filled up. The oil line must also have been purged.

CAUTION: CLOSE THE BLOWER COMPARTMENT ACCESS PANEL BEFORE STARTING THE BURNER.

5- PROLONGED CLOSING

- A) Cut off the electric circuit
- B) Close the oil shut-off valve

NOTE: THE SHUT-OFF VALVE MUST BE CLOSED WHEN THE APPLIANCE IS OUT OF SERVICE FOR A PROLONGED PERIOD OF TIME.

6- MAINTENANCE

At the beginning of heating season, have the complete installation inspected by a qualified service man, especially the lighting system and the controls.

NOTE: THE UNIT'S MAINTENANCE, REPAIRS AND THE CLEANING OF THE OIL FILTER MUST BE DONE BY A QUALIFIED TECHNICIAN.

SERVICE

Before calling for service, first check the following:

- Fuel supply
- Electric fuses or breakers
- Thermostat setting
- PC board settings
- The state of the green diagnostic LED on the burner control.

MAINTENANCE

WARNING: *Turn off electric power supply before servicing the unit.*

1. The furnace, the burner and the flue pipe should be cleaned at least once a year.
2. The nozzle should be inspected and replaced if needed. Handle with care to avoid damaging its surface.
3. The electrodes should be adjusted as indicated in the burner manual.
4. Lubricate the burner motor bearings twice a year. (2 or 3 drops of SAE 20 non detergent lubricating oil).
5. The oil filter should be verified annually and replaced if needed.

Burner no.: _____ Model: _____ Date of installation: _____

Service telephone no.: Day: _____ Night: _____

Dealer's name and address: _____

TEST REPORT :

CO₂ _____% Temp. at stack: _____ Draft at stack: _____ IN.W.C.

Nozzle output: _____ GPH Smoke colour: _____

Inspected by : _____

8- TECHNICAL DATA

8.1 UH – MAX CADDY

MODEL	BURNER TYPE	BTU INPUT	NOZZLE	FLOW	HEAD	STATIC PLATE	PRESSURE AT THE PUMP	H.P. FAN MOTOR	TUBULATOR ADJUSTMENT	AIR ADJUSTMENT	EFFICIENCY
UH-MAX CADDY	BECKETT AFG	91,000	0.65, 70 ⁰ W (DEHAVAN)	0.65 GAL US/H (2.46 L-H)	F0	---	100 PSI (690 kPa)	½	---	0/7	85%
UH-MAX CADDY	BECKETT AFG	120,000	0.65, 70 ⁰ W (DEHAVAN)	0.86 GAL US/H (3.26 L-H)	F0	---	175 PSI (1205 kPa)	½	---	1/6	83%
UH-MAX CADDY	RIELLO 40 F3	91,000	0.50, 70 ⁰ W (DEHAVAN)	0.60 GAL US/H (2.27 L-H)	---	---	150 PSI (1035 kPa)	½	1	2.5	87%
UH-MAX CADDY	RIELLO 40 F3	120,000	0.65, 70 ⁰ W (DEHAVAN)	0.84 GAL US/H (3.18 L-H)	---	---	165 PSI (1135 kPa)	½	1	2.5	85%

For any additional information, consult the rating plate on the left hand side of the appliance.

LIMITED LIFETIME WARRANTY

The warranty of the manufacturer extends only to the original consumer purchaser and is not transferable. This warranty covers brand new products only, which have not been altered, modified nor repaired since shipment from factory. Proof of purchase (dated bill of sale), model name and serial number must be supplied when making any warranty claim to your PSG dealer.

This warranty applies to normal residential use only. Damages caused by misuse, abuse, improper installation, lack of maintenance, over firing, negligence, accident during transportation, power failures, downdrafts, or venting problems are not covered by this warranty.

This warranty does not cover any scratch, corrosion, warping, or discoloration caused by over firing, abrasives or chemical cleaners. Any defect or damage caused by the use of unauthorized parts or others than original parts void this warranty. An authorized qualified technician must perform the installation in accordance with the instructions supplied with this product and all local and national building codes. Any service call related to an improper installation is not covered by this warranty.

The manufacturer may require that defective products be returned or that digital pictures be provided to support the claim. Returned products are to be shipped prepaid to the manufacturer for investigation. If a product is found to be defective, the manufacturer will repair or replace such defect. Transportation fees to ship the product back to the purchaser will be paid by the manufacturer. Repair work covered by the warranty, executed at the purchaser's domicile by an authorized qualified technician requires the prior approval of the manufacturer. Labour cost and repair work to the account of the manufacturer are based on predetermined rate schedule and must not exceed the wholesale price of the replacement part. All parts and labour costs covered by this warranty are limited according to the table below.

The manufacturer at its discretion may decide to repair or replace any part or unit after inspection and investigation of the defect. The manufacturer may, at its discretion, fully discharge all obligations with respect to this warranty by refunding the wholesale price of any warranted but defective parts. The manufacturer shall in no event be responsible for any special, indirect, consequential damages of any nature, which are in excess of the original purchase price of the product. A one-time replacement limit applies to all parts benefiting from a lifetime coverage. This warranty applies to products purchased after March 1st, 2009.

DESCRIPTION	WARRANTY APPLICATION	
	PARTS	LABOUR
Castings, combustion chamber (welds only), castings, and heat exchanger (welds only).	Lifetime	3 years
Stainless steel firebox components, secondary air tubes*, surrounds and heat shields, ash drawer, and plating* (defective manufacture).	5 years	3 years
Carbon steel firebox components, glass retainers, handle assembly, C-Cast baffle*, and vermiculite baffle*.	3 years	1 year
Oil burner, electrical elements, blowers, heat sensors, switches, rheostat, relays, damper motor, fan limit control, PC board, wiring, and other controls.	2 years	1 year
Ceramic glass (thermal breakage only*), paint (peeling), gaskets, insulation, and ceramic fibre blankets.	1 year	n/a
Firebrick	n/a	n/a

**Pictures required*

Shall your unit or a components be defective, contact immediately your **PSG** dealer. Prior to your call make sure you have the following information necessary to your warranty claim treatment:

- Your name, address and telephone number;
- Bill of sale and dealer's name;
- Serial number and model name as indicated on the nameplate fixed to the back of your unit;
- Nature of the defect and any relevant information.

Before shipping your unit or defective component to our plant, you must obtain from your PSG dealer an Authorization Number. Any merchandise shipped to our plant without authorization will be refused automatically and returned to sender.