



Stove Builder International Inc.
1700, Léon-Harmel
Québec(Québec)
G1N 4R9

Installation and Operating Instructions for Wood and Combined Furnaces

THIS MANUAL CONCERNS THE FOLLOWING FURNACES

WOOD

PSG-2000
PSG-3000
PSG-4000
PSG-4500
PSG-5000

COMBINED FURNACES

15, 18 or 20 KW and UH2000
15, 18, 20 or 25KW and UH3000
18, 20, 25 or 30KW and UH4000
18, 20, 25 or 30 KW and UH4500
40, 50 or 60 KW

**All the instructions must be read carefully
before installing and operating furnace.**

CONGRATULATIONS!

You have just purchased one of the best wood or combined
furnace on the market.

We are convinced that your furnace will provide you
with many years of comfort, safely.

Keep these instructions!

TABLE OF CONTENTS

SECTION A : WOOD OR WOOD ELECTRIC FURNACES	4
INTRODUCTION.....	4
1. CHIMNEY AND DRAFT.....	4
2. SAFETY RULES.....	4
<i>GENERAL REQUIREMENTS</i>	4
<i>ODOUR FROM THE PAINT</i>	5
<i>ASH DISPOSAL</i>	5
<i>CREOSOTE BUILD-UP AND REMOVAL</i>	5
<i>SMOKE DETECTOR</i>	6
<i>ASH DRAWER</i>	6
<i>ASH GRATE</i>	6
3. APPLIANCE INSTALLATION.....	6
<i>UNIT LOCATION</i>	6
<i>CLEARANCES TO COMBUSTIBLE MATERIALS</i>	7
<i>PIPE CONNECTOR AND DAMPER</i>	8
<i>DAMPER</i>	9
<i>COMBUSTION AIR</i>	9
<i>PARALLEL INSTALLATION</i>	10
<i>ELECTRICAL CONNECTION</i>	11
<i>ELECTRIC ELEMENT</i>	12
<i>THERMOSTAT</i>	13
<i>FAN CONTROL</i>	13
4. OPERATING INSTRUCTIONS	14
<i>Control system</i>	14
<i>HEATING</i>	15
<i>EARLY SIGNS OF OVERFIRED FURNACE</i>	15
<i>WOOD AS HEATING FUEL</i>	15
<i>CHIMNEY FIRES</i>	16
5. MAINTENANCE.....	16
<i>MAINTENANCE OF THE EXCHANGERS</i>	16
<i>MAINTENANCE OF THE BLOWER MOTOR</i>	17
<i>FILTERS</i>	17
<i>DOOR GASKET MAINTENANCE</i>	17
6. REPLACEMENT PARTS	17
7. ELECTRIC DIAGRAMS FOR UNITS BUILT FROM 2005.....	18
<i>WOOD-ONLY FURNACES</i>	18
<i>PSG 5000 WOOD-ONLY FURNACES</i>	19
9. TECHNICAL SPECIFICATIONS	20
10. SELECTION CRITERIA (COMBINED WOOD/ELECTRIC FURNACE).....	21
11. TROUBLESHOOTING.....	22
12. DUCTS AND REGISTER MEASUREMENTS.....	23
SECTION B : WOOD/OIL COMBINED FURNACES.....	24
GENERAL NOTES	25
1. DRAFT AND CHIMNEY.....	25
2. OIL TANK AND PIPING.....	25
<i>BURNER PUMP</i>	26
3. APPLIANCE INSTALLATION.....	26

<i>LOCATING THE UNIT</i>	26
<i>CLEARANCES TO COMBUSTIBLE MATERIALS</i>	26
<i>POSITIONING THE APPLIANCE</i>	28
<i>PIPE CONNECTOR AND DAMPER</i>	28
<i>COMBUSTION AIR</i>	31
<i>ELECTRIC COMPONENTS INSTALLATION</i>	32
<i>ELECTRICAL WIRING</i>	33
<i>THERMOSTAT</i>	33
<i>FAN CONTROL</i>	33
<i>COMBUSTION SAFETY CONTROL</i>	34
<i>COMBUSTION ADJUSTMENT AND VERIFICATION</i>	35
<i>ELECTRODES SETTING</i>	36
4- APPLIANCE START-UP	37
5- PROLONGED CLOSING	37
7- ELECTRICAL DIAGRAMS.....	39
8- TECHNICAL DATA.....	41
PSG LIMITED LIFETIME WARRANTY	42

REGISTER YOUR WARRANTY ONLINE

To receive full warranty coverage, you will need to show evidence of the date you purchased your furnace. Keep your sales invoice. We also recommend that you register your warranty online at

www.psg-distribution.com

Registering your warranty online will help us track rapidly the information we need on your furnace.

SECTION A : wood or wood electric furnaces

INTRODUCTION.

To get maximum performance from your PSG furnace, keep in mind the following:

- Comply with local codes (if in doubt, contact your local heating specialist).
- Make sure your furnace is installed according to the instructions on the certification plate.
- Make sure that your furnace has been installed in accordance with the required standards specified on the furnace's certification labels.

1. CHIMNEY AND DRAFT

This furnace must be connected to a chimney approved for wood-burning appliances; the chimney connector for a PSG 2000 must have 6" diameter; 7" for PSG3000 and PSG4000, for all other models, use an 8" diameter chimney connector.

Use of a barometric draft control is recommended in order to regulate the draft to the recommended setting. Never use a manual chimney damper.

The barometric control must be adjusted so that the maximum draft measured at the furnace outlet does not exceed -0.06 in. w.c. **Please note that a draft exceeding -0.06 in. w.c. could produce an uncontrollable fire.** On the other hand, the minimum draft required is -0.04 in. w.c. in the evacuation pipe on the wood side, no matter what type of furnace (PSG Wood, PSG Wood/Electric and PSG Wood/Oil).

2. SAFETY RULES

GENERAL REQUIREMENTS

- Never light your furnace using chemicals or other liquid fuels. Never installed automatic feeder on that unit.
- Do not burn wood coated with paint, glue or chemical products.
- Never store wood near the furnace. Respect the required minimum clearances between combustibles and your furnace.
- Keep your furnace, chimney and smoke pipe connector clean and in good working order at all times. We recommend that you establish clear procedures for wood storage, system maintenance and operation of your furnace. Check creosote accumulation daily until you can determine by experience how often to clean. Weekly cleanings may be necessary in mild weather, while a monthly cleaning may be all that is required during the colder months of the year.
- Keep loading and ash drawer doors shut during operation and make sure their gaskets are in good condition. To get a replacement gasket, contact your PSG dealer.
- A plentiful supply of combustion air and a vigorous fire will help prevent creosote accumulation.

All controls adjustments must be performed by a qualified technician. The controls settings and the blower speed must conform to the recommendations of the National Warm Air Heating and Air Conditioning Association and respect the recommended static pressure ranges in the warm air bonnet of the furnace (see General Technical data static pressure).

WARNING

THE ASH DRAWER GET VERY HOT.
DO NOT MANIPULATE WITH BARE HANDS.

ODOUR FROM THE PAINT

It is normal that a smoke odour emanate from the unit when you first light it. It is recommended to burn it at high rate and ventilate the building until the odour resorbs.

ASH DISPOSAL

Ashes must be placed in a metal container with a tight fitting lid. The container should be placed outside, well away from combustible materials. If the ashes are meant to be buried in soil, you should wait until all cinders have thoroughly cooled.

CREOSOTE BUILD-UP AND REMOVAL

When wood is burned slowly, it produces tar and other organic vapours which, when combined with moisture, form creosote. The creosote vapours condensate in a relatively cold chimney flue. As a result, creosote residues accumulate in the flue lining.

N.B.: To minimize the frequency of chimney cleaning, buy your firewood at least one year before using it. Store it in a dry place in order to obtain the minimum moisture rate and optimize the efficiency. Do not store wood or combustible materials within the installation minimum clearances or the space required to reload the appliance and remove the ashes.

When ignited, creosote produces an extremely hot fire inside the chimney.

To avoid this situation, it is important to do the turnover of wood. Inspect the chimney system at regular intervals to determine a cleaning cycle. A weekly cleaning might be required during mild temperature periods but a monthly cleaning should be sufficient during cold periods. **If a significant layer of creosote has accumulated, it must be removed immediately to eliminate the risk of a chimney fire.**

Remember that a small hot fire is preferable to a large smouldering one to prevent creosote build-up within the system. An emergency plan is necessary in case of a chimney fire.

It's recommended to clean the heat exchangers thoroughly at the end of the season in order to help prevent corrosion.

SMOKE DETECTOR

We highly recommend the use of a smoke detector. It must be installed at least 15 feet (4,57 m) from the appliance in order to prevent undue triggering of the detector when reloading.

ASH DRAWER

Your appliance is equipped with an ash drawer to collect ashes produced by the combustion of wood. This drawer must not be left open during combustion as this will cause over firing and serious damage to the furnace. **The drawer must be cleaned regularly.**

It is important that the door and the ash drawer be kept closed while the appliance is in use. Maintain all gaskets in good condition: in case of deterioration, contact your dealer for replacement.

ASH GRATE

You must replace the ash grate if it is damaged and a replacement may be obtained from your dealer.

3. APPLIANCE INSTALLATION

UNIT LOCATION

The furnace must be installed where outside air supply is sufficient for proper combustion. In airtight houses, it might be necessary to install an outside air inlet (see details in: «3- INSTALLATION» COMBUSTION AIR).

The furnace must be positioned so that the connector is as short as possible in order to minimize the use of 90° elbows.

The owner must ensure a proper installation to allow a safe operation of the appliance.

CLEARANCES TO COMBUSTIBLE MATERIALS

N.B. This appliance must be installed in accordance with the instructions on the unit's certification.

MINIMUM CLEARANCES TO COMBUSTIBLE MATERIALS FOR PSG FURNACES

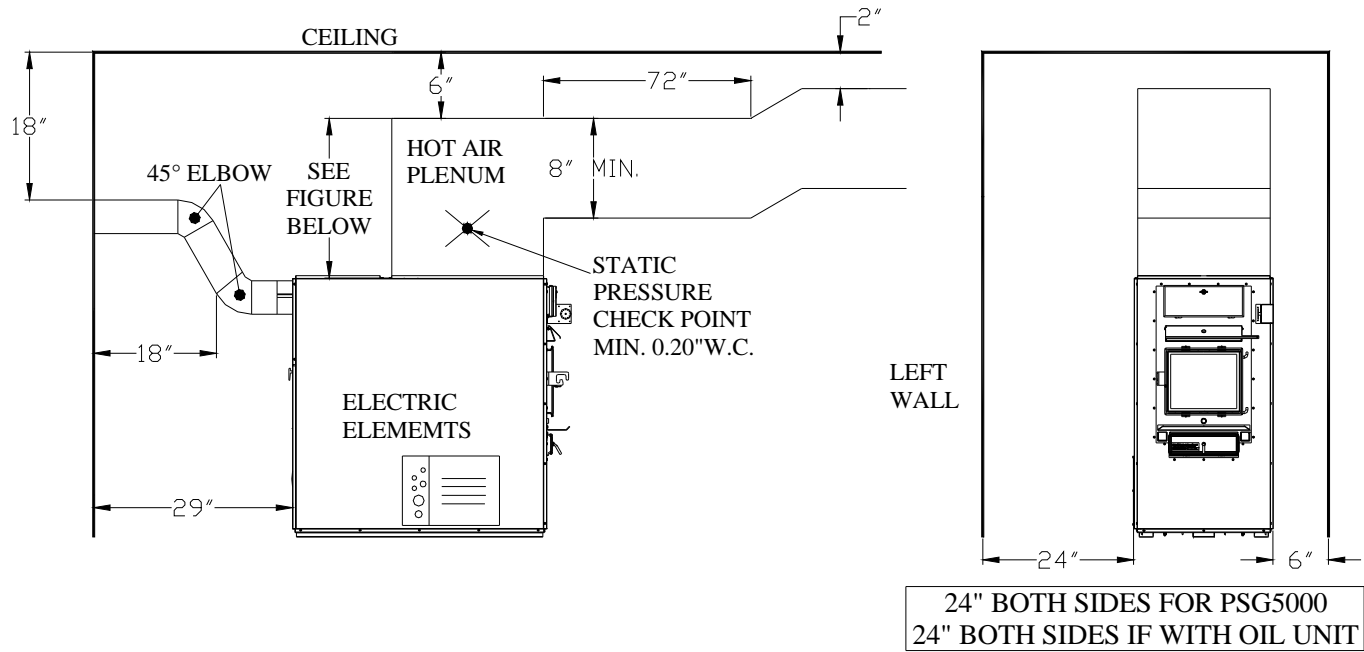

N.B. THE AIR RETURN CONDUITS SHOULD BE AT LEAST EQUAL TO THE COLD AIR PLENUM DIMENSIONS.

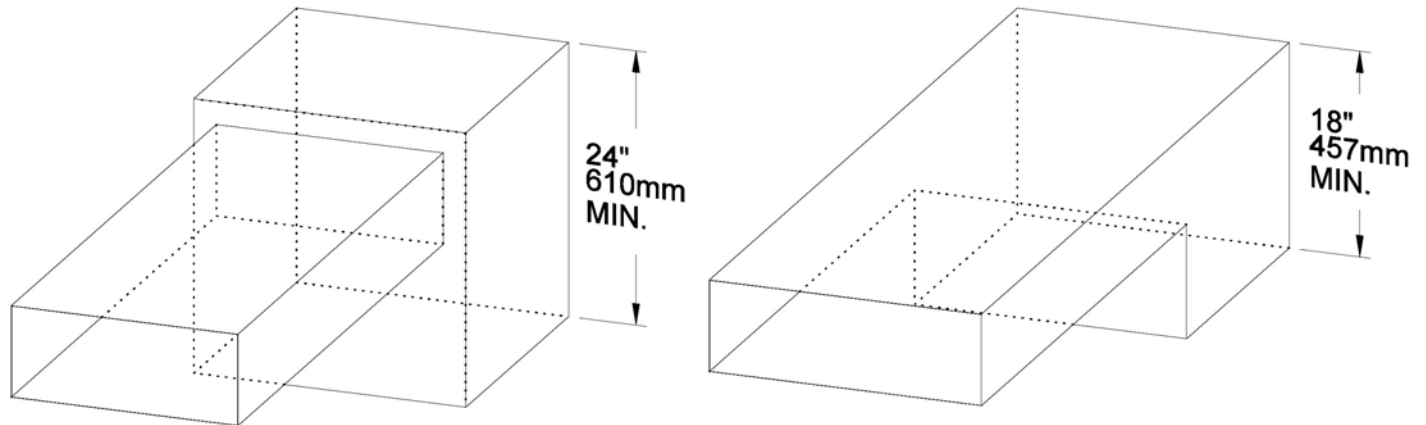

Hot air plenum minimal height.

NOTE: THE HEIGHT OF THE PLENUM MUST BE 24 INCHES FOR THE FURNACES PSG 4000, PSG 4500 AND PSG 5000.

PIPE CONNECTOR AND DAMPER

Before proceeding to connection, remove all accessories such as: scraper, shovel and poker from the evacuation pipe of the furnace.

A 6" diameter chimney listed for use with wood burning heating appliances is recommended for the PSG2000, 7" for PSG3000-4000 and 8" for the others models. If draft exceed -0.06 w.c., you must install a barometric control (see Damper). **Never install a manual damper.**

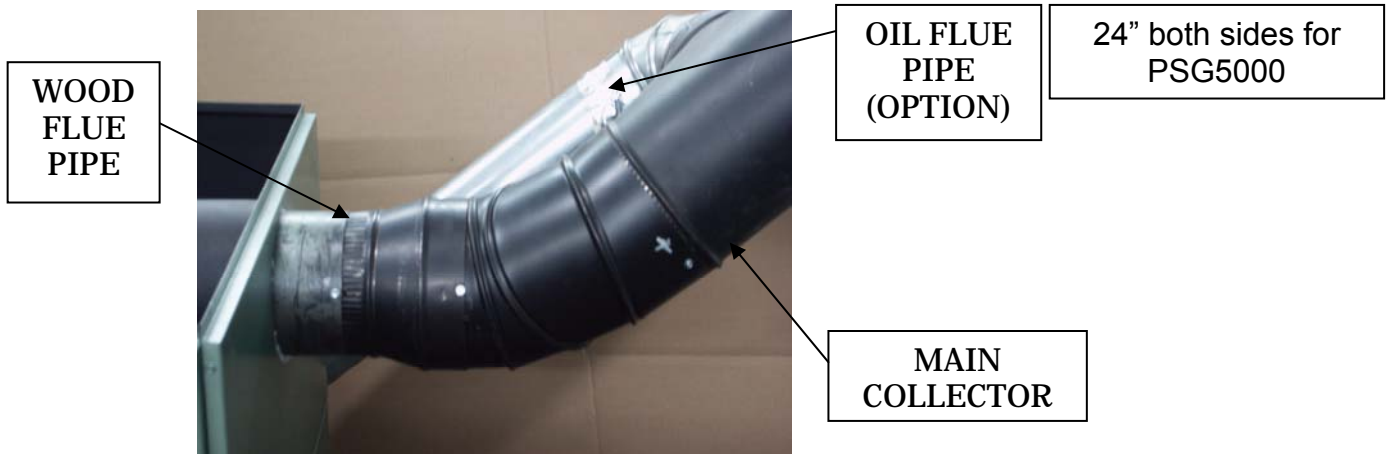

For a proper installation, follow the advices below:

1. All the joints of the evacuation pipe must be secured, using three screws.

Make sure that each screw goes through the inner walls of both connectors (male and female). See pictures below showing a male-female coupling.

PROPER INSTALLATION



UNPROPER INSTALLATION



CAUSE RESTRICTION

2. A minimum rise of 1/4 inch per horizontal foot must be respected.

DAMPER

The barometric control must be adjusted so that the maximum draft measured at the furnace outlet is limited to -0.06 in. w.c. Please note that a draft higher than -0.06 in. H₂O could result in an uncontrollable fire. **On the other hand, the minimum draft to be respected is -0.04 in. w.c. in the evacuation pipe on the solid fuel side, no matter what type of furnace.**

COMBUSTION AIR

In the event that the furnace and the chimney are completely cold, it might be necessary before lighting, to provide fresh air by opening a door or a window for a few minutes.

Take note that a house constructed or renovated in order to be airtight is liable to lack fresh air which is necessary for a proper combustion and a proper operation of heating units.

In such a case, when starting up the fire, do not operate appliances which evacuate air outside the house such as:

- Range hood
- Air exchanger
- Cloths dryer
- Bathroom fan
- Ventilated central vacuum system

NOTE:

It is recommended to install an outside air inlet of minimum 4" diameter in the room where the heating appliance is installed (see drawing below). To do so, it is preferable to choose a wall which is not exposed to extreme winds, according to the conditions surrounding your house.

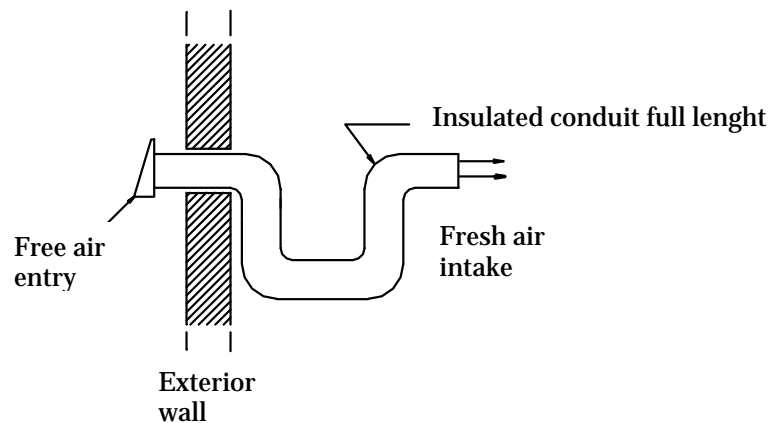

N.B. The owner of the furnace is responsible for the room salubrity in case of negative pressure or temporary negative pressure.

PARALLEL INSTALLATION

The installation of this furnace with another furnace using the same ductwork is not allowed in Canada. **This type of installation is only allowed in the United States.** Ideally, the maximum BTU input of the existing oil, gas, or electric furnace should be equal or higher than the maximum BTU input of the wood furnace. It is mandatory to respect minimum clearances between the ductwork and combustible material as if the wood furnace was installed as a standalone unit. The ductwork and furnace should be adjusted in order to reach a static pressure of at least 0.20 IN.WC, but not more than 0.50 IN.WC. A back-flow damper should be installed in the plenum. The back-flow damper assures that when either unit is operated by itself, the hot air will flow into the home, and not back through the other furnace. Depending on your installation (see figures examples below), a back-flow damper may be required in each plenum.

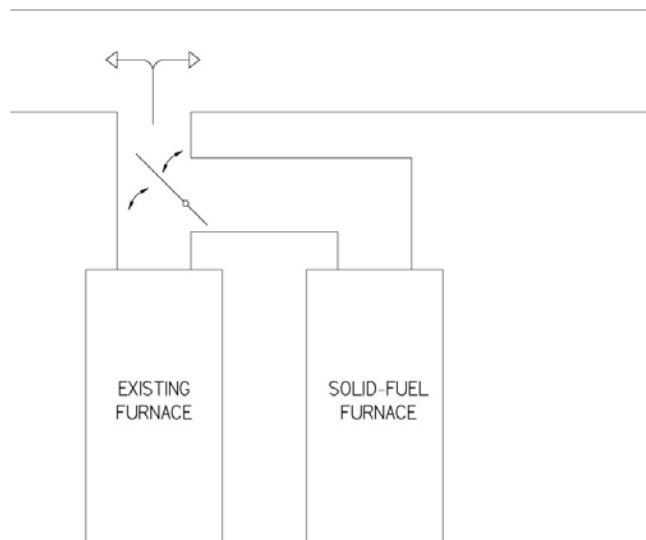
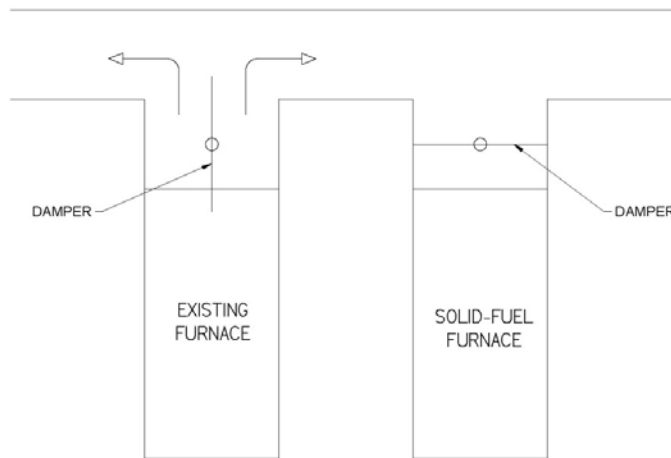

ELECTRICAL CONNECTION

The following instructions do not supersede the local code.

WOOD ONLY

Install the fan limit control on the support provided after securing this support on the left edge of the hot air plenum where two holes are pre-drilled (**there are four pre-drilled holes on the edge of the PSG3000, use the two that are located farther back**). Install the servo-motor on the facade above the door, on the right side (use pre-drilled holes). The chain that links the air inlet latch to the motor must have a play of 1/8 in. When there is no call for heat, the air inlet latch must be completely shut and the chain must be affixed to the servo-motor at "8 o'clock". *

The red switch located on the junction box controls low speed operation of the blower, in either ON (continuous operation) or OFF modes.

WARNING: USE FEEDING WIRES SUITABLE FOR 75°C

WOOD/ELECTRIC

The high limit control on the electric unit is a manual reset thermostatic captor that is located directly inside the electric unit (**see INSIDE VIEW OF THE ELECTRIC ELEMENT**). The electric elements must be installed as shown on the diagram. Install the wood combined fan limit control on the support provided, at the determined location. The connections must conform to the diagram.

Install the servo-motor on the facade above the door, on the right side (use pre-drilled holes). The chain that links the air inlet latch to the motor must have a play of 1/8 in. When there is no call for heat, the air inlet latch must be completely shut and the chain must be affixed to the servo-motor at "8 o'clock". *

WARNING: USE FEEDING WIRES SUITABLE FOR 75°C

* (With all reserves on the minimum combustion air to be increased depending on the type and quality of the combustible).

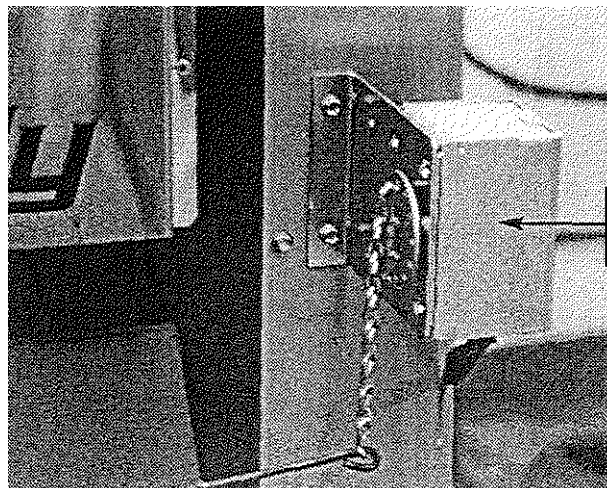

SERVOMOTOR

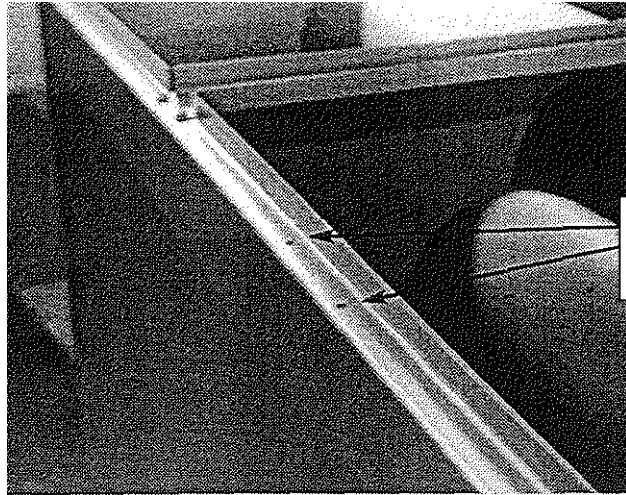

**HOLES FOR FAN
LIMIT CONTROL**

ELECTRIC ELEMENT

The WOOD / ELECTRIC combined model uses two separate thermostats: one thermostat controls the electric heating, the other one controls the wood heating. With this system, the electric heating has priority over the wood heating. When the thermostat activates the electric heating, the air inlet closes down (if opened), the blower starts and the electric elements are successively activated per block of 5 kW. The system may be connected to an outdoor sensor which will allow the last block of elements (5 kW) to start up only when the outside temperature is cold enough. This will reduce the power of the systems by 5 kW during mild temperature for more economy and comfort.

When the call for electric heat is completed, the wood system will take over if the setting of the wood thermostat is higher than that of the electric thermostat.

So, in normal bi-energy use, you should set the wood system thermostat 2° to 3° higher than the electric system thermostat.

Take note furnaces equipped with the G10 blower have a four speed motor and furnaces equipped with the G-12 have 2 speed motor and an adjustable pulley.

If the temperature of the element exceeds the limit allowed, the thermostatic captor will disengage the elements. To reactivate, press the red "manual reset" button on the L-170 thermodisk; find out why the temperature limit has been exceeded (static pressure too high, fan breakage, dirty filter, etc.) before reactivating.

INSIDE VIEW OF THE ELECTRIC ELEMENT

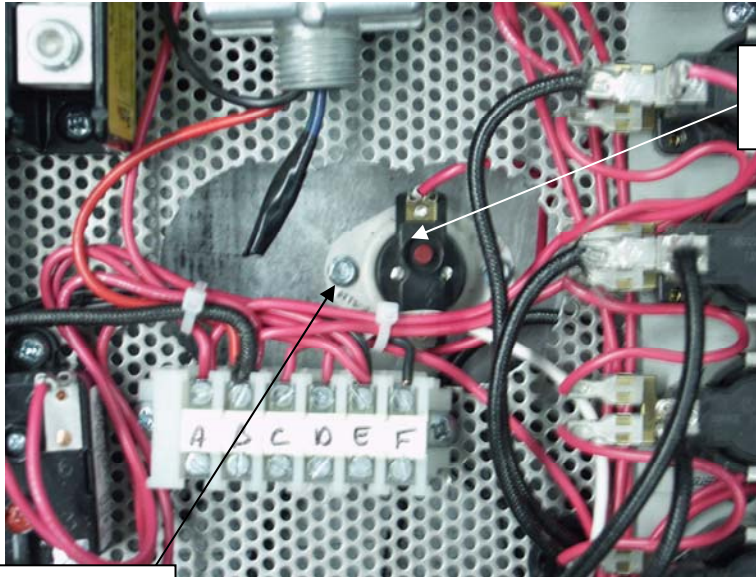

**Red button
manual reset**

Thermodisk L-170

OUTSIDE VIEW OF THE ELECTRIC ELEMENT

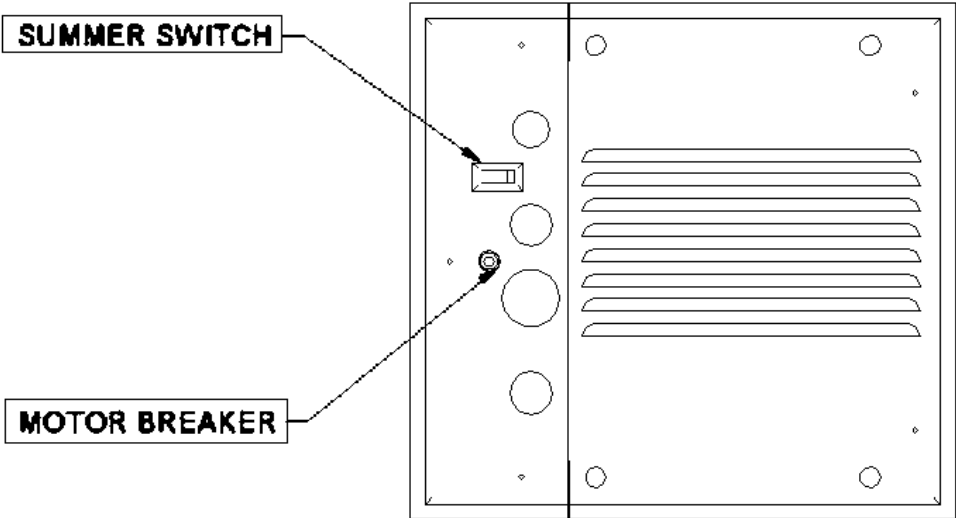

THERMOSTAT

The thermostat must be installed on an inside wall in a location where it is not likely to be affected by the draft coming from an air outlet. It must be installed at a minimum of 55 inches above the floor.

N.B. The combined wood / electric model uses two thermostats and they should be installed at same height.

FAN CONTROL

The fan control setting may vary depending on the type of installation. The "out of service" temperature is factory set at 110° F and the "in service" temperature is factory set at 150° F. These settings should provide a proper operation for most installations.

It is preferable for a prolonged operation of the blower that the setting "out of service" be low enough. But a setting "out of service" too low will cause cold air circulation. To modify the settings, move the tabs at the desired position on the temperature scale.

The adjustment of all controls must be performed by a qualified technician. The controls setting and the blower speed must conform to the recommendations of the "Warm Air Heating and Air Conditioning National Association".

The red switch located on the electric unit controls the low speed (summer speed) either at the "on" or the "off" position. For a better efficiency, we recommend to let the blower be controlled automatically when heating with wood.

4. OPERATING INSTRUCTIONS

Control system

On the wood furnaces only, the thermostat controls the air inlet damper. When the thermostat calls for heat, the damper opens and the fire burns up. When the furnace gets hot enough, the combined limit control activates the blower motor at the speed selected for wood heating.

The chain that links the air inlet damper to the motor must have a play of 1/8 inch. When there is no call for heat, the air inlet damper must be completely closed and the chain must be affixed to the servo-motor at "8 o'clock". *

* (With all reserve on the minimum air to be increased depending on the type and quality of the combustible).

LIGHTING:

1. Open the door

Note: If there is already a bed of coals in the combustion chamber, go directly to PREHEATING.

2. Drop the ashes into the ash pan
3. Place one or two dry kindlings at the front of the combustion chamber
4. Place newspaper strips on top of the kindlings.
5. Cover the newspaper with more kindlings and small pieces of dry wood.
6. Add newspaper strips, then light the fire as low as possible and leave the door 1/2" (13 mm) opened. If you fail lighting the fire, you might experience a back draft through the air inlets.

PREHEATING

1. Once the kindling is well ignited or the coals revived, put 2 or 3 fire logs in such a way that the flames can interlace between the logs then close the door. It is important to respect these loading sequences so that the wood will burn from the front to the back of the furnace.
2. Wait 15 to 20 minutes, then proceed with loading the furnace.

HEATING

1. When loading the furnace, lower the kindled pieces of wood and place them at the center of the combustion chamber before adding new logs.
2. Do not overload. Air must circulate freely in the upper part of the furnace in order to obtain an efficient operation of the appliance. Please note that a small hot fire will produce much less residues than a large smouldering one.

IMPORTANT: DURING THE HEATING PROCESS, REMOVE THE ASHES AND EMBERS THAT COULD OBSTRUCT THE AIR INTAKE LOCATED BELOW THE DOOR INSIDE THE FURNACE.

PROCEDURE TO OPEN THE LOADING DOOR

TO MINIMIZE THE RISK OF A BACK DRAUGHT OPEN THE DOOR 1" AND WAIT ABOUT 10 SECONDS BEFORE OPENING COMPLETELY. THE PURPOSE IS TO STABILIZE THE PRESSURE INSIDE THE FURNACE.

EARLY SIGNS OF OVERFIRED FURNACE

1. Roaring fire.
2. Chimney connector is glowing red.
3. Extreme heat coming from the furnace. If this occurs, **DO NOT OPEN THE DOOR**, shut-off the air inlet opening completely, and wait until the glow has completely subsided.

ALWAYS KEEP THE DOOR AND THE ASH DRAWER CLOSED
(except for lighting and maintenance).

WOOD AS HEATING FUEL

We recommend that you burn dry wood only.

There are two important factors to be considered when choosing a type of wood: the moisture content and the wood density. Hardwood, such as maple, oak and beech will provide better results because of the high density and minimal tar produced during combustion. It is highly recommended to use wood that has been dried at least six months. **Do not use coal as heating fuel in this appliance.**

Whenever a high amount of smoke is noticed in the room, you must:

1. Open doors and windows.
2. Make sure the furnace door is closed as well as the damper (if necessary, lower the thermostat starting point or undo the chain of the damper and close manually the barometric draft control).
3. When the furnace has cooled down, inspect the chimney to detect obstructions and consult a specialist to determine the cause of the smoke spillage.

CARBON MONOXYDE IS A LETHAL GAS (ODOURLESS AND COLOURLESS), WHICH YOU MUST BEWARE OF.

CHIMNEY FIRES

Chimney fires might occur when the fire gets extremely hot. Burning cardboard, branches or pieces of wood can ignite the creosote residue accumulated in the evacuation flue system. The usual signs are:

1. Rumbling
2. The flue gets extremely hot
3. Flames are coming out of the chimney

In case of a chimney fire, first call your local fire department and sprinkle the roof around the chimney with water.

Make sure that the furnace door is closed as well as the damper (if necessary, lower the thermostat starting point or release the chain from the damper and CLOSE the barometric draft control manually).

If the fire gets uncontrollable due to an improper use or because the draft is too strong, follow the same procedure as in a chimney fire except that you will have to OPEN manually the barometric draft control.

LOCAL FIRE DEPARTMENT.

Phone number: _____

5. MAINTENANCE

MAINTENANCE OF THE EXCHANGERS

The evacuation pipe and the heat exchangers should be inspected regularly during the burning season. Using the scraper, clean the exchanger pipes thoroughly on a regular basis.

INSTRUCTIONS

- 1° Wait until fire is completely out before cleaning.
- 2° Remove the smoke pipe connector from the furnace.
- 3° Inspect the furnace's heat exchangers (rectangular tubes) through the smoke outlet for creosote accumulation. On the PSG5000, you can access the heat exchangers by removing the square panel located at the back of the furnace.
- 4° Using the supplied scraper, clean the heat exchangers and the combustion chamber and remove creosote residues.
- 5° Reassemble the smoke pipe connector or access panels.

CHIMNEY MAINTENANCE

One of the most efficient methods is to sweep the chimney, using a hard brush. Brush up and down. Soot and creosote residue will come off the inside surface and fall at the bottom of the chimney where it can be removed easily.

The chimney must be checked regularly and if creosote has accumulated, it must be removed. Cleaning on a monthly basis should be sufficient during the coldest months.

Smoke flue inspection

- The smoke flue should be inspected regularly during the heating season.
- If possible, the smoke flue should be dismantled and cleaned.
- The flue should be inspected to detect any defect.
- If no defect is noticed, put the flue back in place; otherwise, it must be replaced.
- Use only wood as a combustible.
- Seasoned hard wood logs 18" to 22" long are recommended as a combustible.

Regular maintenance is required for safe and efficient operation of a controlled-combustion heating system. Chimney, gaskets and smoke pipes must remain in good working condition.

MAINTENANCE OF THE BLOWER MOTOR

The two bearings of the motor must be lubricated once a year using non detergent SAE 20 oil.

DO NOT OVERLUBRICATE

FILTERS

The furnace must not be operated without the filters. The air filters must be cleaned or replaced regularly. Use the same size and preferably the same type as the original filters.

DOOR GASKET MAINTENANCE

It is important to maintain the door gasket in good condition. After a while, the gasket might sag and a door adjustment may be required to prevent air leakage; if adjustment is not sufficient, replace the gasket.

We recommend to replace the gasket that seals the door once a year in order to maintain a good control of the combustion for maximum efficiency and security. To replace your door gasket, remove the old gasket and glue. Clean the surface thoroughly, apply the gasket glue and put the new gasket onto the door. Wait for at least 2 hours before lighting your furnace.

6. REPLACEMENT PARTS

Your PSG furnace is designed to burn clean and requires minimal maintenance. It's recommended to conduct a visual inspection at least once a month to uncover any damage to the unit. Any damage must be repaired as soon as possible using genuine PSG replacement parts. You can find a complete list of replacement parts on our website at www.psg-distribution.com.

7. ELECTRIC DIAGRAMS FOR UNITS BUILT FROM 2005

WOOD-ONLY FURNACES

FAN LIMIT HONEYWELL L6064(MOTOR (G-10) 4 SPEED AND (G-12) 2 SPEED)

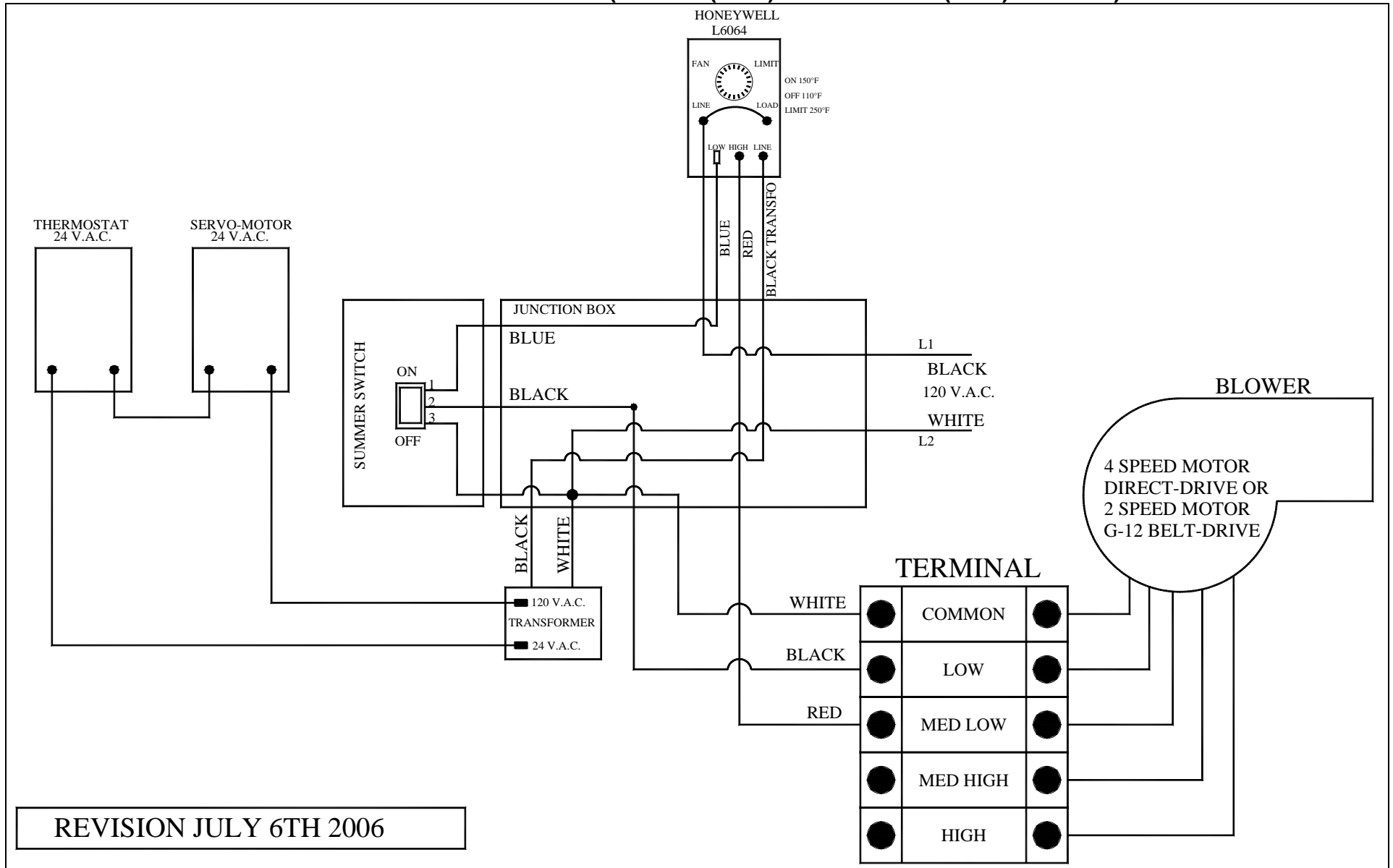

REVISION JULY 6TH 2006

PSG 5000 WOOD-ONLY FURNACES

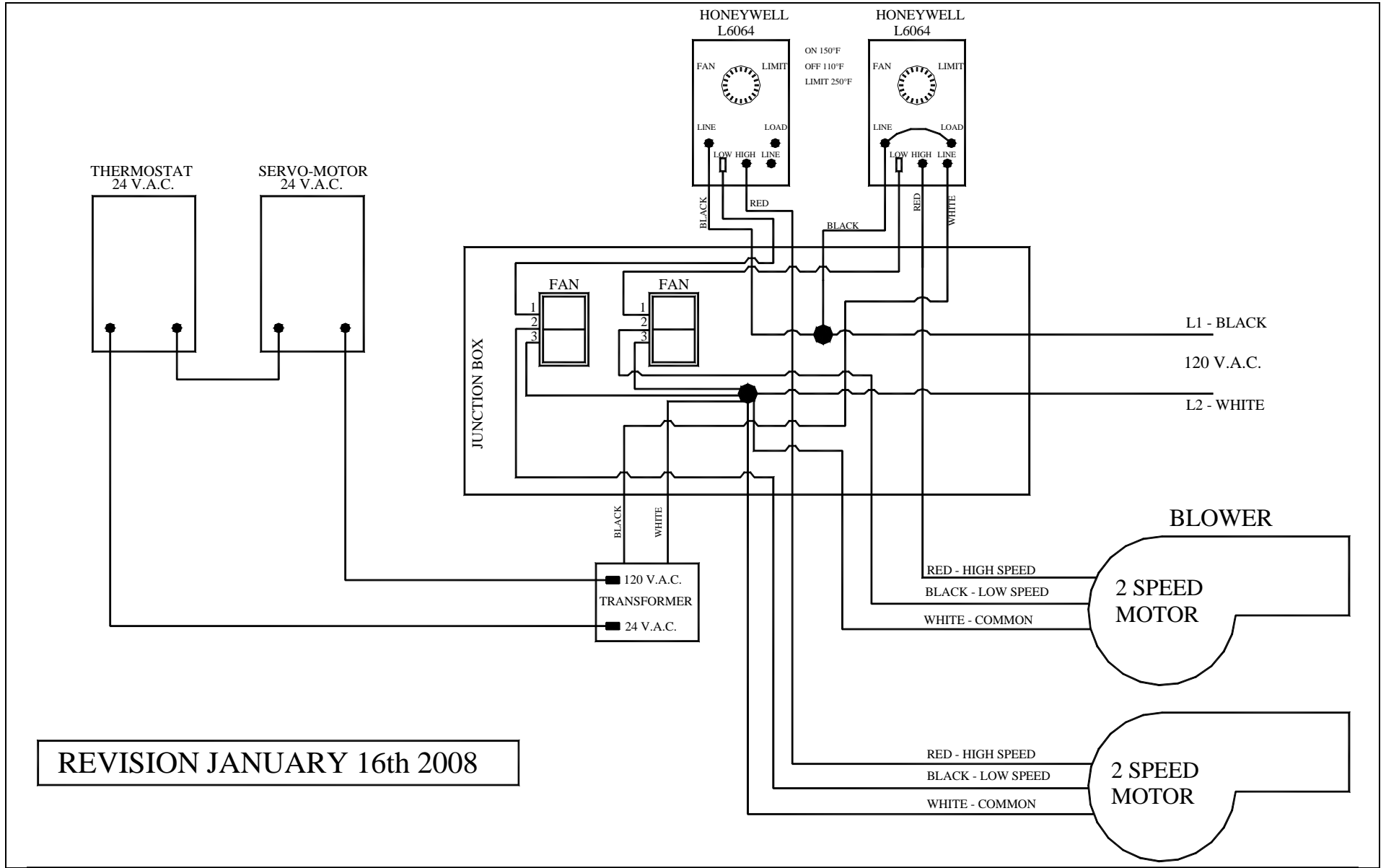

REVISION JANUARY 16th 2008

9. TECHNICAL SPECIFICATIONS

	2000	3000	4000	4500	5000
A	45 ¼"	47"	50"	52 ½"	54 ½"
B	23 ½"	25 ½"	29 ½"	33 ½"	54"
C	45 ½"	47 ¼"	48"	48"	56 ¾"
D	15 ⅞"	15 ⅞"	19"	19"	19 ¾"
E	26 ⅜"	28"	28"	30"	31 ½"
F	22 ½"	24 ½"	28 ½"	32 ½"	51 ⅞"
G	40 ½"	41 ¼"	42"	42"	49 ½"
PIPES	7"	8"	8"	8"	8"
WEIGHT	445	540	600	660	1200

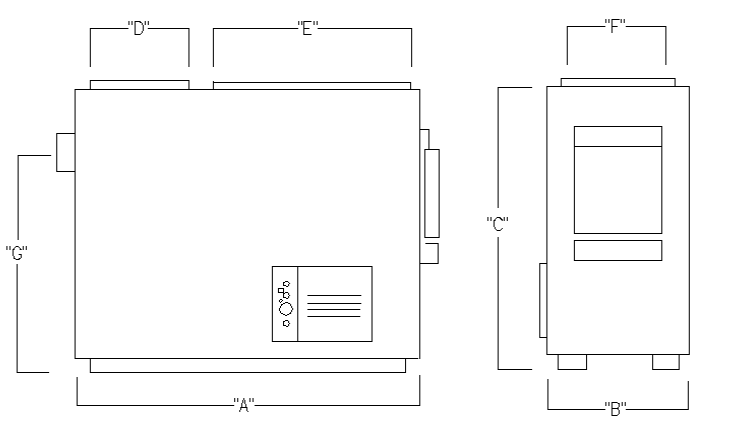

GENERAL TECHNICAL DATA

MODEL	BELT DRIVE			DIRECT DRIVE			OUTPUT (C.F.M.)	TEMP VAR. (° F)	BTU INPUT (WOOD)	STATIC PRESSURE ("WATER)		FILTER (2)
	FAN	MOTOR	SPEED	FAN	MOTOR	SPEED				H ₂ O		
2000	N/A			G-10	1/3	4	950	68	70000	0,2	0,4	11 x 20
3000	N/A			G-10	1/3	4	1300	78	110000	0,2	0,6	12 x 24
4000	N/A			G-10	1/3	4	1300	128	180000	0,2	0,6	12 x 24
4000	G-12	3/4	2	N/A			1800	93	180000	0,2	0,8	12 x 24
4500	G-12	3/4	2	N/A			1800	121	235000	0,2	0,8	12 x 24
5000	G-12	3/4	2	N/A			2600	125	350000	0,2	1,45	20 x 24

TECHNICAL DATA – ELECTRIC MODE

MODEL	OUTPUT (C.F.M.)	TEMP. VAR. (° F)	BTU/HR	AMPERES TOTAL	BREAKER REQUIRED	FEEDER GAUGE	VOLTAGE SINGLE PHASE	ELEMENTS QTY
15 KW	950 1300	50 36	51195	75	100	4	120/240	3 – 5 KW
18 KW	950 1300	60 44	61434	87	125	4	120/240	2 – 5 KW, 2 – 4 KW
20 KW	950 1300	67 49	68260	95	125	3	120/240	4 – 5 KW
25 KW	950 1300 1800	83 61 44	85325	115	150	2	120/240	5 – 5 KW
30 KW	1300 1800	73 53	102390	140	175	1	120/240	6 – 5 KW
WOOD				15			120	

10. SELECTION CRITERIA (COMBINED WOOD/ELECTRIC FURNACE)

RESIDENTIAL AREA

House including: basement, first floor and second floor (half)

Floor area *	New house	Existing house
1100 square feet or less	PSG 2000 – 15KW	PSG 2000 – 18 or 20KW
1100 to 1450 square feet	PSG 3000 – 18KW	PSG 3000 – 20 or 25KW
1400 to 2000 square feet	PSG 4000 – 20KW	PSG 4000(G-12)– 25 or 30KW
2000 to 3000 square feet	PSG 4500 – 25KW	PSG 4500 – 30KW

COMMERCIAL AREA

Building including: Walls 14 to 16 feet high
Garage doors, no basement

Floor area	
2500 to 3800 square feet	PSG 4500- 25 or 30KW
4000 to 10000 square feet	PSG 5000 – 40, 50 or 60KW

* Consider main floor only.

11. TROUBLESHOOTING

PROBLEM	CAUSES	SOLUTIONS
1. Sudden drop in heating performance follows adequate heating from first loadings.	Ash accumulation at lower intake blocks combustion air intake and causes deposits in heat exchanger and flue pipes.	Clear air intake of any ash accumulation. Clean heat exchanger and flue pipes.
2. Insufficient heat from first loadings, low draft	Wrong setting of draft regulator (opening too large). Restriction in chimney flue (excessive length of chimney connector, right-angled elbows).	Set draft regulator (reduce opening). Reduce distance between furnace and chimney and eliminate 90° elbows. Maximum length: 10 feet. Tight-angle elbows: maximum 3.
3. Poor heating in the rooms while hot air plenum and furnace are hot.	Inadequate duct installation. Insufficient static pressure. Unbalanced system (too many hot air outlets for too few cold air intakes).	Reposition ducts.
4. Furnace burns too much wood.	The thermostats controlling the air combustion damper is located too close to cold air and demands heat continuously. Wrong setting of air intake register. Poor building insulation. Ash drawer left open. Furnace too small for heating needs. Unbalanced ventilation system, insufficient heat near thermostat.	Relocate thermostat. Adjust chain between damper motor and combustion air damper. Balance the ventilation system as to increase the flow air in room where thermostat is located.
5. Fan starts too late.	Fan starting temperature is too high. Cold air return is too cold. Inappropriate location of fan limit control in hot air plenum.	Lower starting temperature (the fan limit control is normally set at 150°F); under certain conditions, this limit should be reduced. Reduce the cold air intake. Relocate fan limit control within the hot air plenum.
6. Creosote accumulation, very average performance.	Damp wood. Insufficient draft. Clogged chimney.	Use dry wood. Adjust draft regulator. Clean chimney, chimney connector and furnace heat exchangers.
7. Hot air plenum remains barely warm while furnace in full operation.	Damp wood. Too much cold air return in relation to hot air ducts. Unbalanced ventilation system.	Use dry wood. Balance ventilation system.

IMPORTANT NOTE

WE STRONGLY RECOMMEND CONSULTING A HEATING SYSTEM SPECIALIST FOR THE INSTALLATION OF A CENTRAL HEATING VENTILATION SYSTEM.

N.B.: STOVE BUILDER INTERNATIONAL INC. IS NOT LIABLE FOR ANY FAULTY INSTALLATION WHICH RENDERS THIS UNIT INOPERATIVE

12. DUCTS AND REGISTER MEASUREMENTS

(sample calculations)

SIMPLIFIED METHOD DISTRIBUTION SYSTEM

WARM AIR SYSTEM INSTALLATION

Ducts size (heat)

4 inch outlet reduce by 1"

5 inch outlet reduce by 2" Always by 8" thick

6 inch outlet reduce by 3"

N.B.: The main duct must be reduced every 2 outlets.

Ducts specifications (heat)

Dimensions	Length	Elbow	Average equivalence
4"	10'	1 x 90°	Max 4,000 Btu
5"	10'	1 x 90°	Max 6,000 Btu
6"	10'	1 x 90°	Max 7,000 Btu

DAMPER

For a 4" warm air outlet: 2" x 10" damper

For a 5" warm air outlet: 2" x 12" damper or 4" x 10"

For a 6" warm air outlet: 2" x 14" damper or 4" x 12"

HOUSE DIMENSIONS

Example: 28 x 40 bungalow: 1,120 sq. ft.

28 x 40 x 8: 8,960 cu. ft. x 1.8 Ch. air/hr: 16,128 Btu

Exposed walls:

40 + 40 + 28 + 28: 136 x 8: 1,088 cu. ft. x 22: 23,936 Btu

Number of windows:

12 of 3 x 4: 144 x 60: 8,640 Btu

Number of doors:

2 x 3 x 7: 42 x 100: 4,200 Btu

52,904 Btu

Non-insulated basement: 25%

Insulated basement: 15% 7,906 Btu

or 54 Btu per sq. ft. 60,840 Btu

FOR ELECTRIC ELEMENTS 80%:48,672 Btu or 14,28 kW

TO BE ADDED:House 1 1/2 floor = 25%

House 2 floors = 40%

BEDROOM (for example: 12 x 12)

12 x 12 x 8: 1,152 cu. ft. x 1.8 Ch. air/hr: 2,074 Btu

Exposed walls:

12 + 12 x 8: 192 x 22: 4,224 Btu

Windows:

3 x 4 x 60 720 Btu

7,018 Btu

SECTION B : wood/oil combined furnaces

**INSTALLATION
AND OPERATION INSTRUCTIONS
FOR WOOD/OIL BURNING
COMBINED FURNACES
PSG/UH 2000-3000-4000 AND 4500**

**READ THIS MANUAL THOROUGHLY
BEFORE OPERATING THE FURNACE**

CERTIFIED BY OMNI TESTING LABORATORIES ACCORDING TO CAN/CSA B366.1-M91, UL391 3e ed. 1995, rev. 1999 & CAN/CSA B212-93 (JUNE 2000)

CAUTION

CAUTION

EXPLOSION OR FIRE HAZARD.
FOR YOUR SAFETY: DO NOT
STORE OR USE GASOLINE OR
ANY FLAMMABLE LIQUIDS OR
VAPORS IN THE VICINITY OF
THIS HEATING UNIT.

DO NOT ATTEMPT TO LIGHT THE
BURNER WHEN EXCESS OIL HAS
ACCUMULATED, WHEN THE
APPLIANCE IS FULL OF VAPOR OR
WHEN THE COMBUSTION
CHAMBER IS VERY HOT.

DO NOT BURN WASTES OR PAPER IN THE APPLIANCE.
DO NOT LEAVE PAPER OR ANY COMBUSTIBLE MATERIAL
AROUND THE APPLIANCE.

PLEASE SAVE THESE DOCUMENTS!

GENERAL NOTES

This instruction manual treats mainly of the oil burning unit of your wood/oil combination furnace.

For any additional information concerning the wood burning furnace, please consult your installation and operation instructions manual for wood and wood/electricity furnaces.

To obtain the optimal efficiency, follow the advices below regarding the installation and operation of your WOOD/OIL combination furnace.

Respect the local codes (when in doubt, consult your local heating appliances dealer).

Make sure that the clearances indicated in the instruction manual correspond to the specifications on the certification plate.

Make sure that your furnace is installed in conformity with the instructions on the name plate.

All the controls adjustments must be performed by a qualified technician. The controls settings and the fan speed must be in compliance with the recommendations of the Warm Air Heating and Air Conditioning National Association and must respect the static pressure ranges in the warm air plenum of the furnace.

THE INSTALLATION OF THE WOOD/OIL COMBINATION FURNACE MUST BE DONE IN ACCORDANCE WITH THE RULES OF THE AUTHORITIES HAVING JURISDICTION AND THE CAN/CSA B-139 M-91 STANDARD FOR OIL BURNING HEATING APPLIANCES.

The oil burning furnaces are not approved for use with combustible heavier than No.2 oil (furnace oil). **DO NOT USE GASOLINE, TRANSMISSION OIL OR OTHER TYPE OF OIL CONTAINING GASOLINE.**

1. DRAFT AND CHIMNEY

The chimney must conform to the rules of the authorities having jurisdiction and the CAN/CSA B139 M-91 & NFPA 31 standard regarding installation of oil burning heating appliances. The installation of the connecting pipes to the oil unit must be done and approved by a qualified pipe fitter.

The barometric damper provided with the appliance must be properly installed on the flue pipe of the oil unit. The purpose of the damper is to limit the draft, if necessary, in the oil unit evacuation pipe.

Since the evacuation pipe of the oil unit is connected to the evacuation pipe of the wood burning furnace, **the minimum draft to be respected at all times in the evacuation pipe of the wood burning side is - 0.04" W.C.**

2. OIL TANK AND PIPING

The maximum capacity of the tank must be 200 gallons and the tank must be located at least 7 feet from the burner. Local codes will govern the size of the air inlets and filling openings as well as the type of plugs to be used. 1 1/4" IPS and 2" IPS are usually accepted as minimum dimensions for the air intake and fill pipes, respectively. The oil line to the burner must be a 3/8" outside diameter copper tubing for runs up to 50 feet and 1/2" o.d. for longer runs. A manual shut-off valve and an oil filter shall follow in sequence on the

oil line between the oil tank and the burner. The oil line cannot be buried and must be protected adequately to avoid any damage.

BURNER PUMP

The burner is equipped with a single stage pump. When the pump is connected to a single feeder pipe, a maximum rise of 8 feet is allowed. This height is measured from the tank outlet level to the burner inlet.

When the rise is more than 8 feet but not exceeding 10 feet, a by-pass plug (provided with the burner) and an oil return pipe must be installed. **For more details, see “INSTALLATION INFORMATIONS”, Part No. 21844 on the burner pump.**

If the rise is higher than 10 feet, a two stage pump may be required along with an oil return pipe.

3. APPLIANCE INSTALLATION

LOCATING THE UNIT

The furnace must be installed in a location where combustion air is available in sufficient quantity. In airtight houses, the installation of an outside air intake might be required. (See details in 3- APPLIANCE INSTALLATION, COMBUSTION AIR).

The owner is responsible for ensuring a proper installation to allow a salubrious operation of the appliance.

Position the furnace so that the connecting pipe is as short as possible and limit the use of 90° elbows to a minimum.

Provide sufficient clearance to permit easy access for maintenance of the filters, motors, controls and pipe connectors.

CLEARANCES TO COMBUSTIBLE MATERIALS

MINIMUM INSTALLATION CLEARANCES TO COMBUSTIBLE MATERIALS	
WARM AIR PLENUM AND FIRST 6 FEET OF DUCT	6 in.(152 mm)
WARM AIR PLENUM AFTER THE FIRST 6 FEET = B	2 in. (51 mm)
REAR (INCLUDING CLEARANCE FOR MAINTENANCE) = A	29 in. (737 mm)
SIDES (INCLUDING CLEARANCE FOR MAINTENANCE)	24 in.(610 mm)
OIL BURNING UNIT FLUE PIPE	9 in.(229 mm)
WOOD BURNING FURNACE FLUE PIPE	18 in.(458 mm)
* FLOOR	0 in.(0 mm)

*** ON A COMBUSTIBLE FLOOR,THE USE OF A FLOOR PROTECTION EXCEEDING THE UNIT BY 8 INCHES ON THE SIDE AND REAR AND 18 INCHES IN FRONT IS RECOMMENDED.**

N.B. These appliances must be installed in conformity with the instructions on the name plate.

N.B. FOR AIR RETURN, RESPECT THE OPENING SURFACE OF THE RETURN AIR PLENUM OF THE FURNACE.

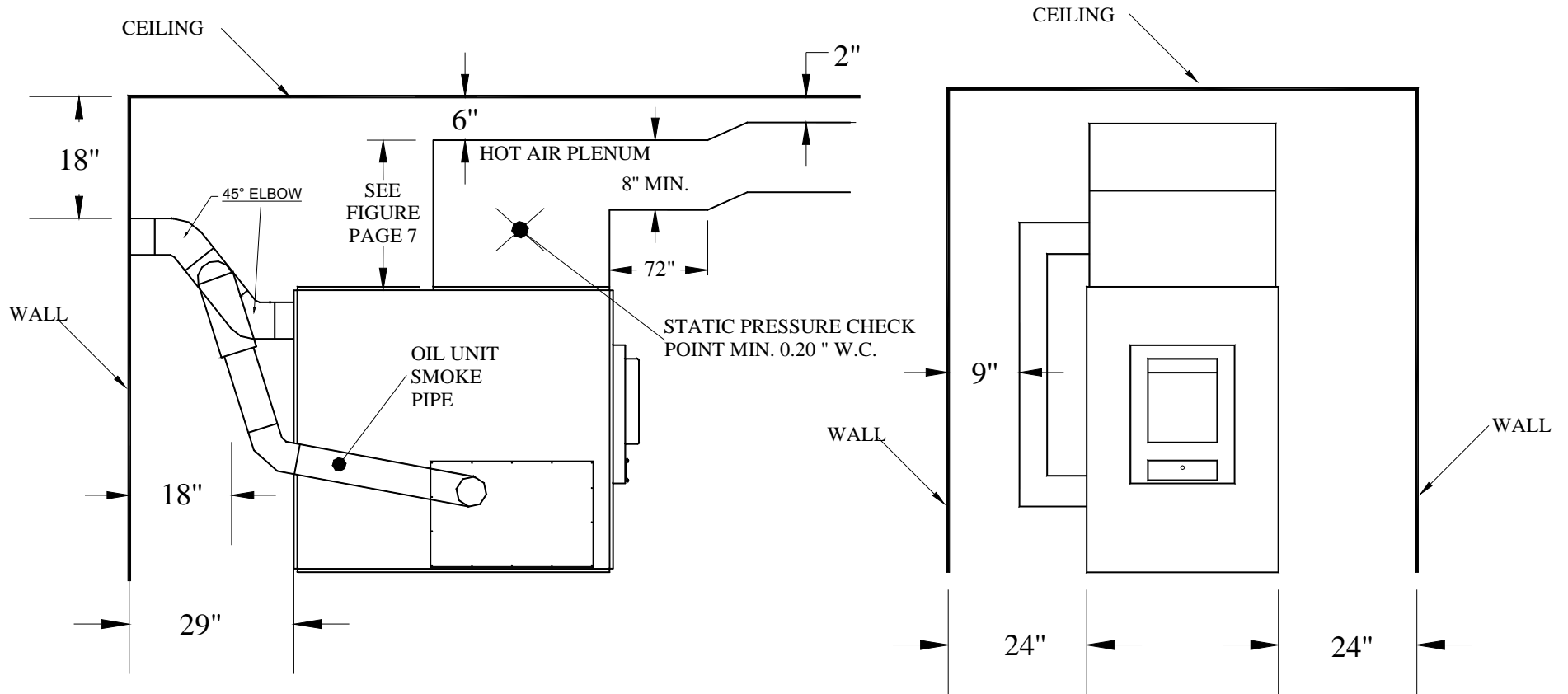

POSITIONING THE APPLIANCE

For a safe and quiet operation, the furnace must be levelled in both directions. Give each “U” shape block, an equal support so that the weight is evenly distributed.

PIPE CONNECTOR AND DAMPER

The pipe connecting the furnace to the chimney must be as short as possible. Whenever possible, the use of 45° elbows is recommended for a better evacuation of the smoke in the chimney, for both the wood burning furnace and the oil burning unit (UH). The barometric damper provided with the appliance must be installed in the oil unit evacuation pipe, approximately 24" from the flue outlet of the oil unit.

TYPE OF FURNACE	(UH) OIL UNIT FLUE PIPE DIAMETER
PSG/UH 2000	5"
PSG/UH 3000	5"
PSG/UH 4000	5"
PSG/UH 4500	6"

DIFFERENT INSTALLATIONS FOR PSG/UH-2000-4000-4500

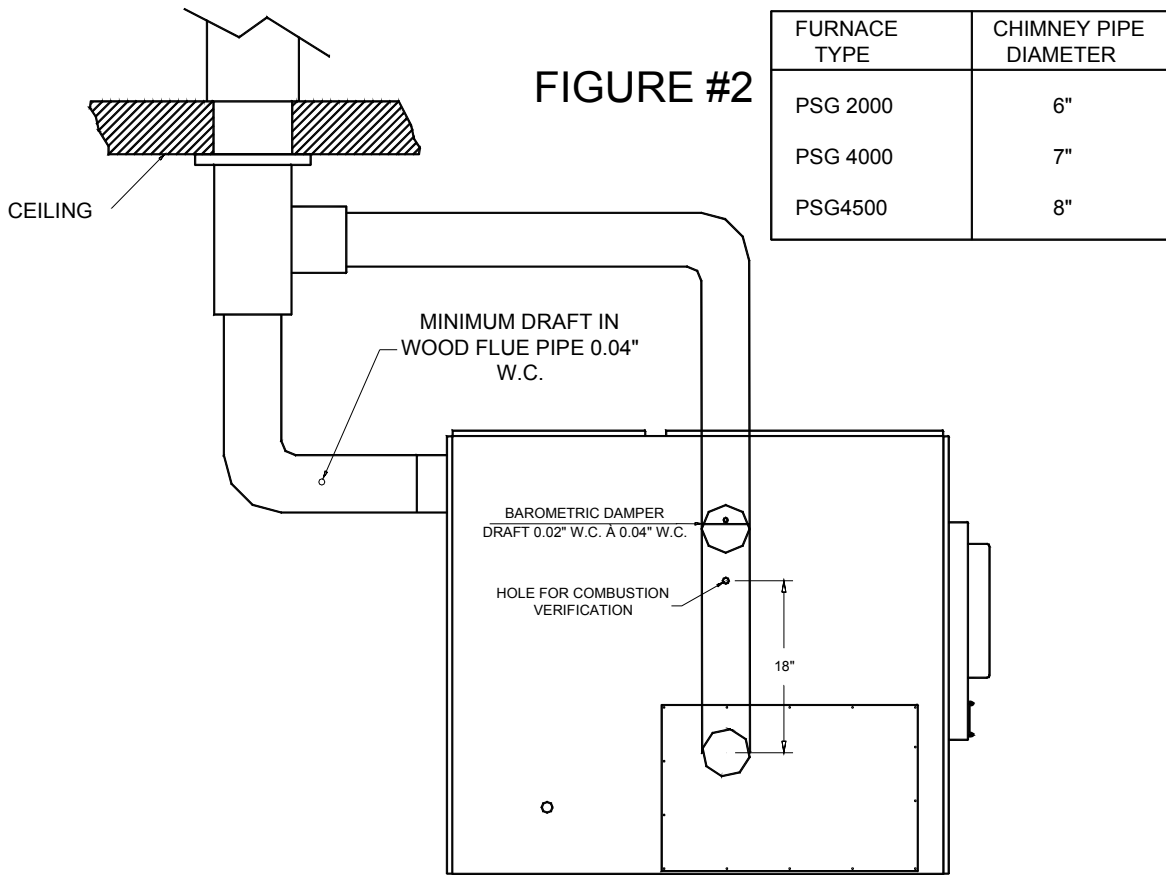
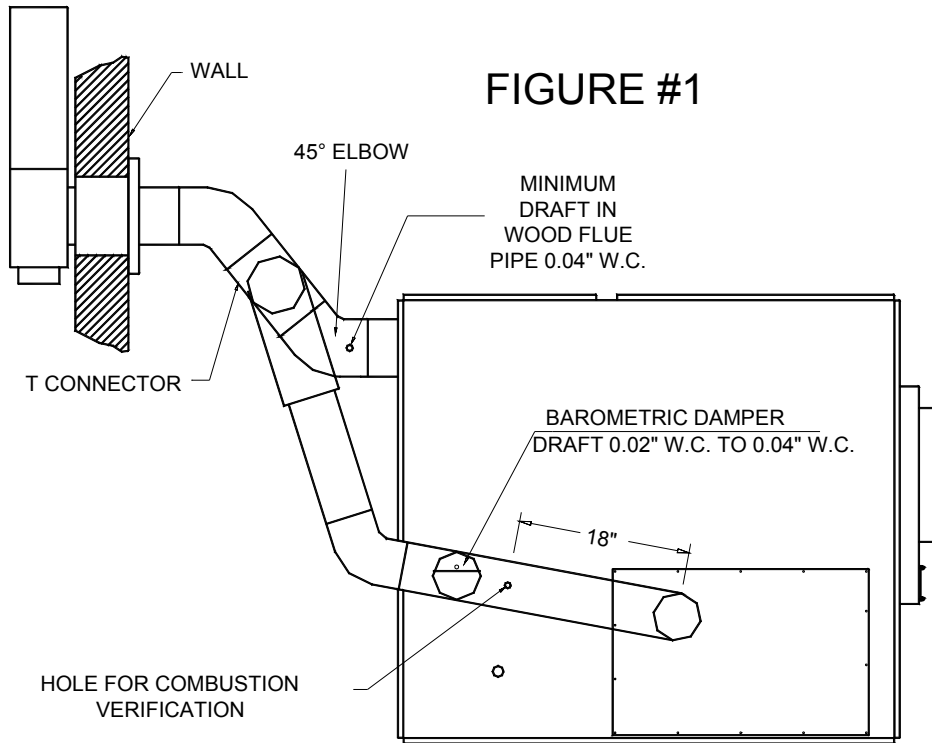

FOR PSG/UH-3000

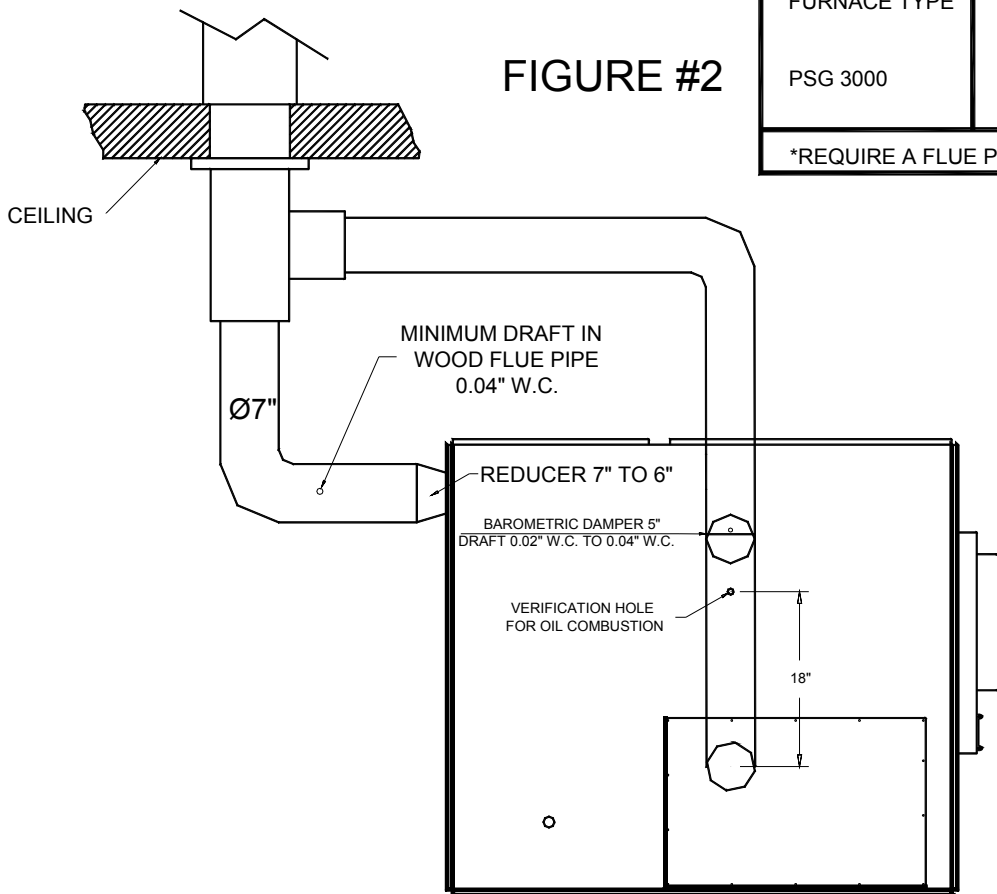
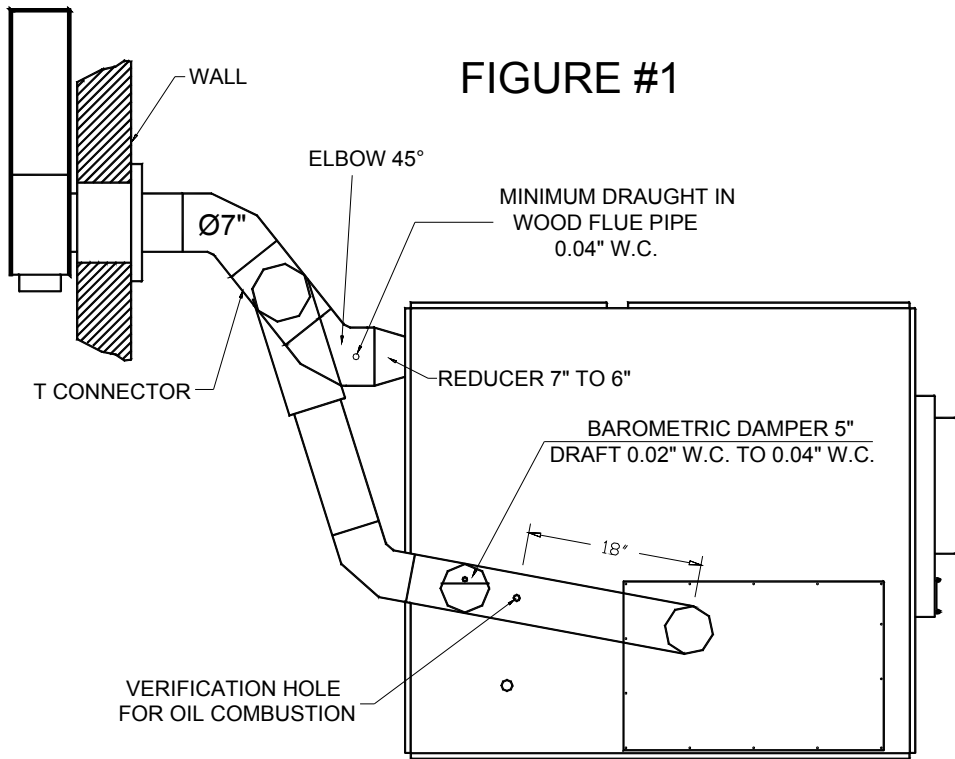

FURNACE TYPE	CHIMNEY PIPE DIAMETER
PSG 3000	*7"
*REQUIRE A FLUE PIPE REDUCER	

COMBUSTION AIR

Take note that an airtight house is liable to lack the fresh air needed for proper combustion, specially if you are using appliances that evacuate air from the house, such as:

- Range hood
- Air exchanger
- Clothes dryer
- Bathroom fan
- Central vacuum cleaning system

In that case, it is recommended to install a 4" fresh air inlet in the room or next to the room where the heating appliance is located (see drawing below); choose a wall which is not exposed to dominant winds, depending on the conditions surrounding your house.

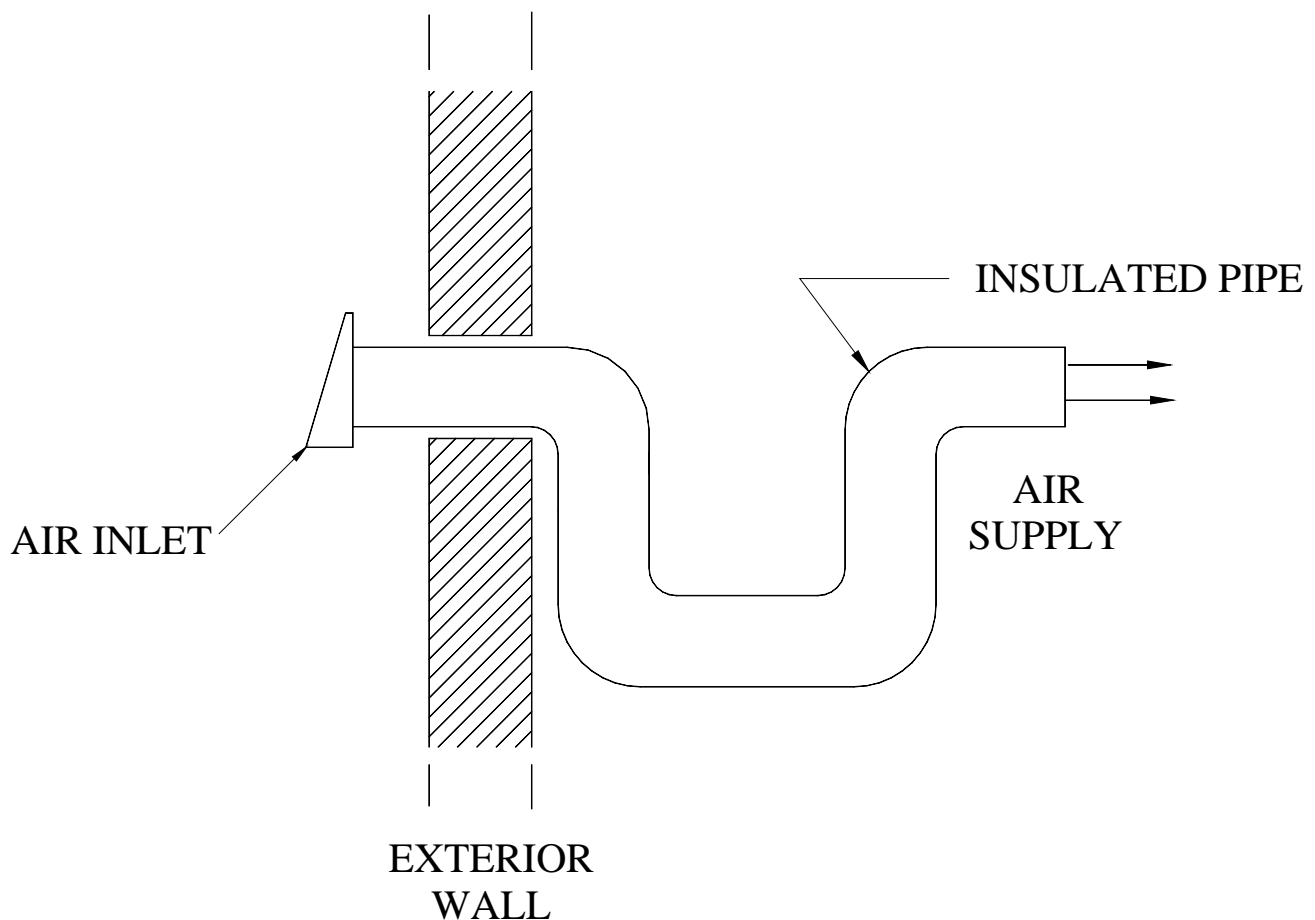

N.B. The owner is responsible for the salubrity of the premises in case of negative pressure or temporary negative pressure.

ELECTRIC COMPONENTS INSTALLATION

All the wires joining the electric components must have the proper length. Run the wires connecting the servo-motor to the relay-transformer away from surfaces that may get hot (see figure #1).

FIGURE #1

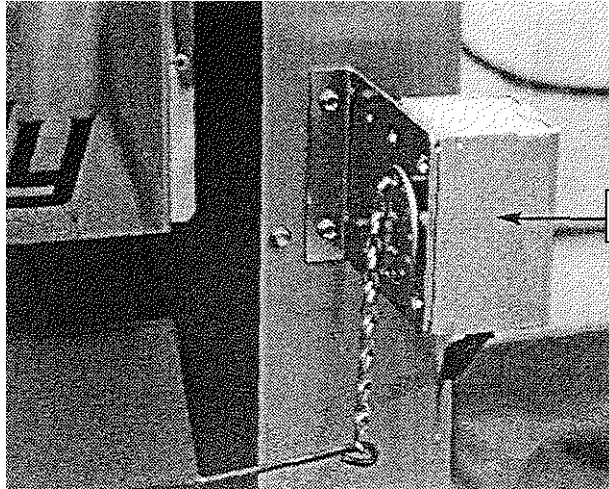

SERVO-MOTOR

FAN LIMIT INSTALLATION ON PSG UH-2000-3000 AND 4000 MODELS

The wood fan limit control must be installed with the mounting bracket, in the warm air plenum on the left hand side of the appliance; two holes are pre-drilled on the edge to match the holes on the mounting bracket (see fig. #3). On the PSG3000, there are four pre-drilled holes, use the ones located further back.

The fan limit control for the oil unit (affixed to the junction box and relay-transformer, see figure #2) must be installed on the lower left hand side removable panel, near the oil flue outlet; a 1" diameter hole is pre-punched to allow the insertion of the fan limit's probe).

FIGURE #2

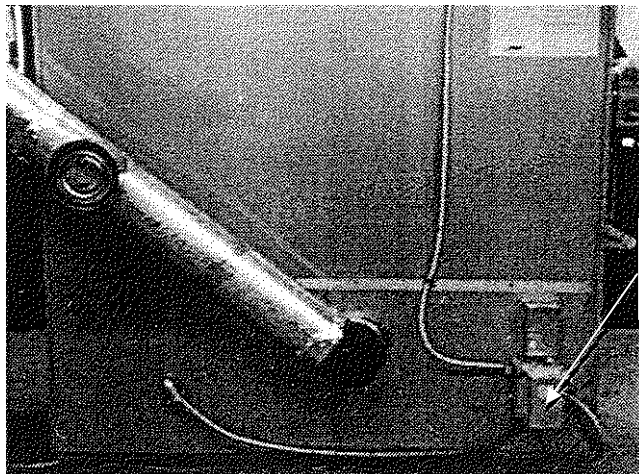

RELAY
TRANSFORMER

FIGURE #3

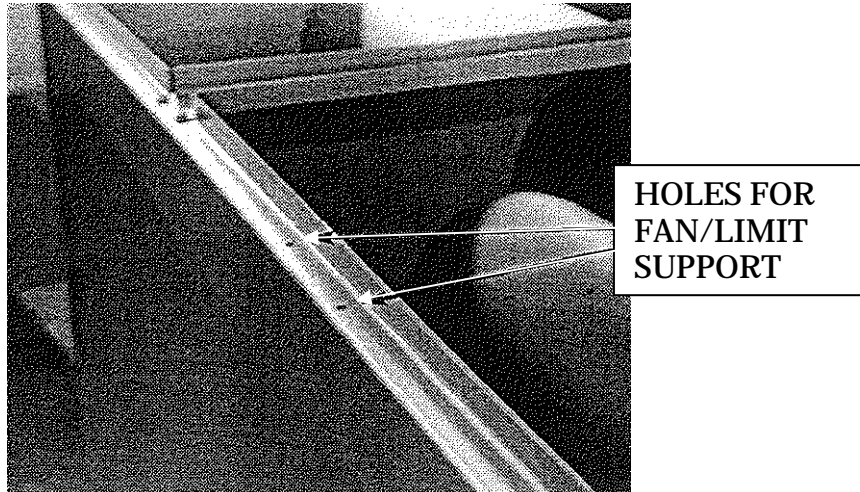

FAN LIMIT CONTROL INSTALLATION ON MODEL PSG/UH-4500

The wood unit fan limit control must be installed with the mounting bracket in the warm air plenum on the right hand side of the appliance (two holes are pre-drilled on the upper edge of the furnace to receive the mounting bracket). The fan limit control for the oil burning unit must be installed on the upper right part of the appliance's front panel (a 1" diameter hole is pre-punched in order to insert the fan limit's sensor in the furnace).

N.B. On the PSG/UH-4500, the **wood** fan limit control is the one that is attached to the junction box and relay-transformer.

ELECTRICAL WIRING

The whole wiring from the distribution panel to the heating unit shall comply with the applicable electrical standards and local codes. The unit should be connected to its own 15 amp/120VAC electric circuit (see electrical diagram).

THERMOSTAT

Both the wood and oil thermostats must be installed side by side on an interior wall, in a location where they are not affected by the air draft coming from the furnace's blower; they must be level and at least 55 inches above the floor.

FAN CONTROL

The fan limit control settings may vary according to the type of building and heating installation; the "fan off" setting is factory set at 100°F and the "fan on" setting positioned as close as physically possible to the "fan" off" setting; these settings should allow a proper operation for most installations

In order for the blower to run for long enough periods, the "fan off" setting must not be set too high but too low a setting will result in undesirable cold air circulation. To modify the settings, move the tabs to the desired position on the temperature scale of the fan limit control.

All adjustments of the controls must be performed by a qualified technician. The controls settings and the blower speeds must be set in accordance with the recommendations of the Warm Air Heating and Air Conditioning National Association.

To obtain a continuous air circulation during summer months, simply turn the manual switch "ON". The summer switch is located on the controls junction box.

It is not recommended to let the blower run on continuous mode when heating with wood as the wood furnace must reach a certain temperature before the blower starts to perform adequately.

COMBUSTION SAFETY CONTROL

The AFG type oil burner is equipped with an electronic control (# R7184B1032) including a pre-purge function and a new more durable drive motor.

PRE-PURGE

When there is a call for heat, the burner's fan will run for 15 seconds before the actual ignition takes place to vent the combustion chamber and generate a proper draft. This will result in a smoother ignition of the oil burner.

SAFE OPERATION

If the flame goes out while the burner is running, the CAD cell will detect it; the control will then switch to the "RECYCLE" mode and cut the fuel supply to the burner for 60 seconds. After this delay, the control goes back to "IGNITION" mode. If the flame goes out 3 times in a row, the control will switch to the "LOCKOUT" mode to prevent a continuous cycling of the ignition process, which would cause a premature sooting of the combustion chamber and smoke pipe. To deactivate the "LOCKOUT" mode, press and hold the reset button of the control for 30 seconds.

A green diagnostic LED on the control has four states:

- On = Flame present
- Off = No flame
- 2 seconds On, 2 seconds Off = "Recycle" mode
- 1/2 second On, 1/2 second Off = "Lockout" mode TEMPORARY SHUT-OFF

By pressing and holding the reset button, the burner will shut-off until the reset button is released. Then, the control will start over at the beginning of the normal cycle.

FOR ADDITIONAL INFORMATIONS ON OPERATION SEQUENCES OF THE BURNER, CONSULT THE BURNER INSTRUCTION MANUAL.

COMBUSTION ADJUSTMENT AND VERIFICATION

To enjoy the efficiency of our oil burning units, you must respect the following criteria:

TOOLS REQUIRED:

- DRAFT GAUGE
- SMOKE TESTER
- PUMP PRESSURE GAUGE
- NOZZLE AND ELECTRODES POSITION GAGE
- COMBUSTION TESTER

CHECK LIST:

- SELECTION OF NOZZLE AND HEAD
- NOZZLE / ELECTRODES POSITION IN RELATION TO THE HEAD
- PUMP PRESSURE
- OIL LINE IS BLEED
- LOW FIRING RATE BAFFLE (INSIDE THE BURNER) REQUIRED FOR UH-2000-3000-4000 AND UH-CADDY. NOT REQUIRED FOR UH-4500
- FAN SPEED
- BAROMETRIC DAMPER POSITION

COMBUSTION VERIFICATION PROCEDURE:

- A- DRILL A 9/32" DIAMETER HOLE IN THE EVACUATION PIPE APPROXIMATELY 18" FROM THE OUTLET.
 - B- CLOSE THE DOOR AND THE AIR INTAKE(S) OF THE WOOD BURNING FURNACE.
 - C- LIGHT THE BURNER FOR AT LEAST 10 TO 15 MINUTES.
 - D- OVER THE FIRE DRAUGHT = -0.01 TO -0.02 W.C. (THE DRAFT OVER THE FIRE MUST BE MEASURED IN THE OPENING IN THE PULSATION TRAP).
 - E- SMOKE TEST BETWEEN 0 AND 1 ON THE SHELL BACHARACH SCALE (TRACES).
 - F- DRAFT IN THE CHIMNEY =-0.02 TO -0.04 W.C.
 - G- PERCENTAGE OF EXCESS AIR = 20 TO 40%, 12% CO₂, 4.6% O₂.
 - H- AVERAGE EFFICIENCY OF 80 TO 85 %.
 - I- TIGHTEN ALL THE LOCKING SCREWS AFTER COMPLETING THE FINAL ADJUSTMENT.
- N.B. – The barometric damper provided with the appliance must be properly installed on the flue pipe of the oil burning unit. The purpose of the damper is to adjust the draft in the evacuation pipe of the oil burning unit to the recommended level. Since the evacuation pipe of the oil burning unit is connected on the evacuation pipe of the wood burning furnace, the minimum draft to be respected is 0.04" W.C. in the evacuation pipe of the wood burning side, at all time. ***In fact, a barometric damper that would be opened too wide could cause an important loss of draft in the evacuation pipe of the wood burning furnace.***

ELECTRODES SETTING

The electrodes must be adjusted by a qualified technician. A proper positioning of the electrodes is important to get an efficient lighting of the oil.

ELECTRODE SETTING FOR "F" HEAD

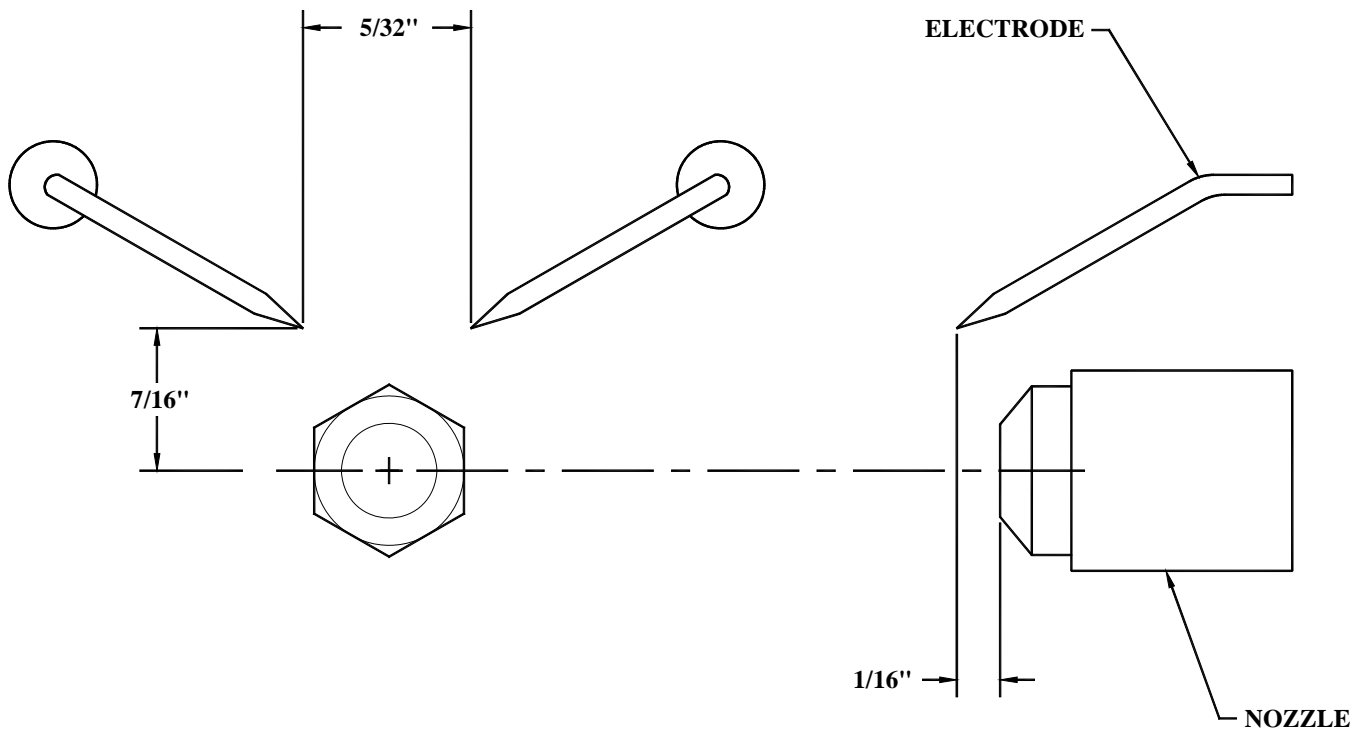

WARNING:

1. REFER TO THE RATING PLATE FOR THE PUMP PRESSURE AND THE NOZZLE TYPE.
2. REFER TO THE BECKETT INSTRUCTION MANUAL FOR DETAILS ON THE BECKETT PUMP.
3. FOR ELECTRODES SETTING SEE THE BECKETT MANUAL.
4. FOR THE START-UP AND ADJUSTMENT OF THE BURNER SEE THE INSTRUCTION MANUAL OF THE BURNER.
5. IN CASE OF BURNER FAILURE, REFER TO THE BURNER MANUAL.

4- APPLIANCE START-UP

The start-up must be performed by a qualified technician. Make sure the installation is completed and the oil tank has been filled up. The oil line must also have been purged.

CAUTION: CLOSE THE BLOWER COMPARTMENT ACCESS PANEL BEFORE STARTING THE BURNER.

5- PROLONGED CLOSING

- A) Cut off the electric circuit
- B) Close the oil shut-off valve

NOTE: The shut-off valve must be closed when the appliance is out of service for a prolonged period of time.

6- MAINTENANCE

At the beginning of heating season, have the complete installation inspected by a qualified service man, especially the lighting system and the controls.

NOTE: THE UNIT'S MAINTENANCE, REPAIRS AND THE CLEANING OF THE OIL FILTER MUST BE DONE BY A QUALIFIED TECHNICIAN.

SERVICE:

Before calling for service, first check the following:

- Fuel supply
- Electric fuses or breakers
- Thermostat setting
- Fan limit controls settings
- The state of the green diagnostic LED on the burner control (see section: 3. APPLIANCE INSTALLATION, COMBUSTION SAFETY CONTROL).

MAINTENANCE:

WARNING: *Turn off electric power supply before servicing the unit.*

1. The furnace, the burner and the flue pipe should be cleaned at least once a year.
2. The nozzle should be inspected and replaced if needed.
Handle with care to avoid damaging its surface.
3. The electrodes should be adjusted as indicated in the burner manual.
4. Lubricate the burner motor bearings twice a year.
(2 or 3 drops of SAE 20 non detergent lubricating oil).
5. The oil filter should be replaced at least once a year.

Burner no.: _____ Model: _____ Date of installation: _____

Service Telephone no.: Day: _____ Night: _____

Dealer's name and address: _____

TEST REPORT :

CO₂ _____% Temp. at stack: _____ Draft at stack: _____ w.c.

Nozzle output: _____ GPH Smoke colour: _____

Inspected by : _____

FILTERS

The furnace should never be operated without filters.

This applies especially to temporary heating during construction period. Operating the furnace without filters would allow dust and other particles in the air to circulate freely and to penetrate into the fans and motors carters causing damage and possible failure. Clean and replace filters as often as required.

Note : **The operation cost is higher and efficiency lower when using a dirty filter.**

7- ELECTRICAL DIAGRAMS

WIRING DIAGRAM FOR PSG/UH – 2000 – 3000 - 4000

(The location of the wood limit is on the plenum and the location of the oil limit is on the panel towards exhaust pipe)

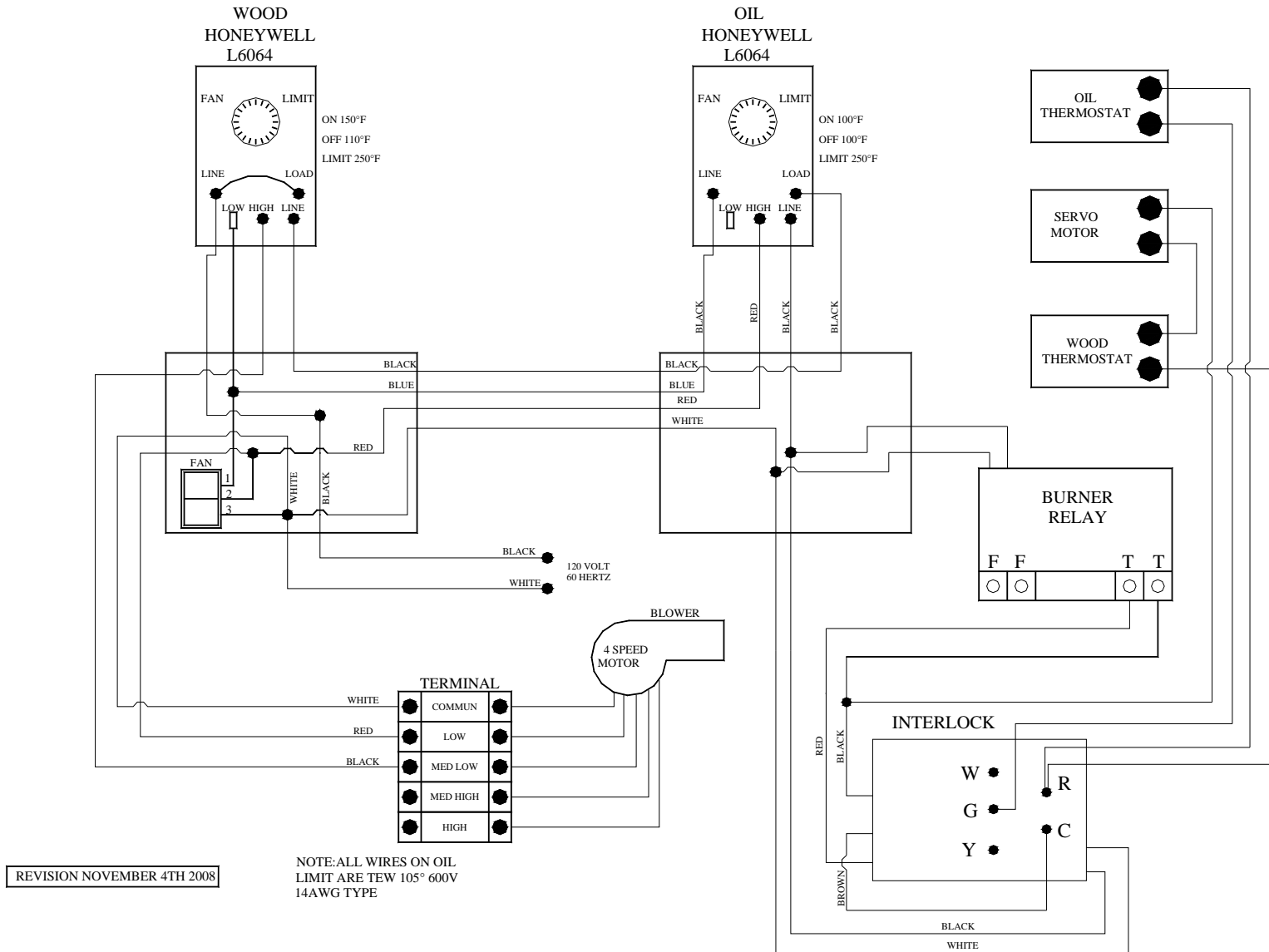

WIRING DIAGRAM FOR PSG/UH – 4500

(The location of the wood limit is on the plenum and the location of the oil limit is on the front panel)

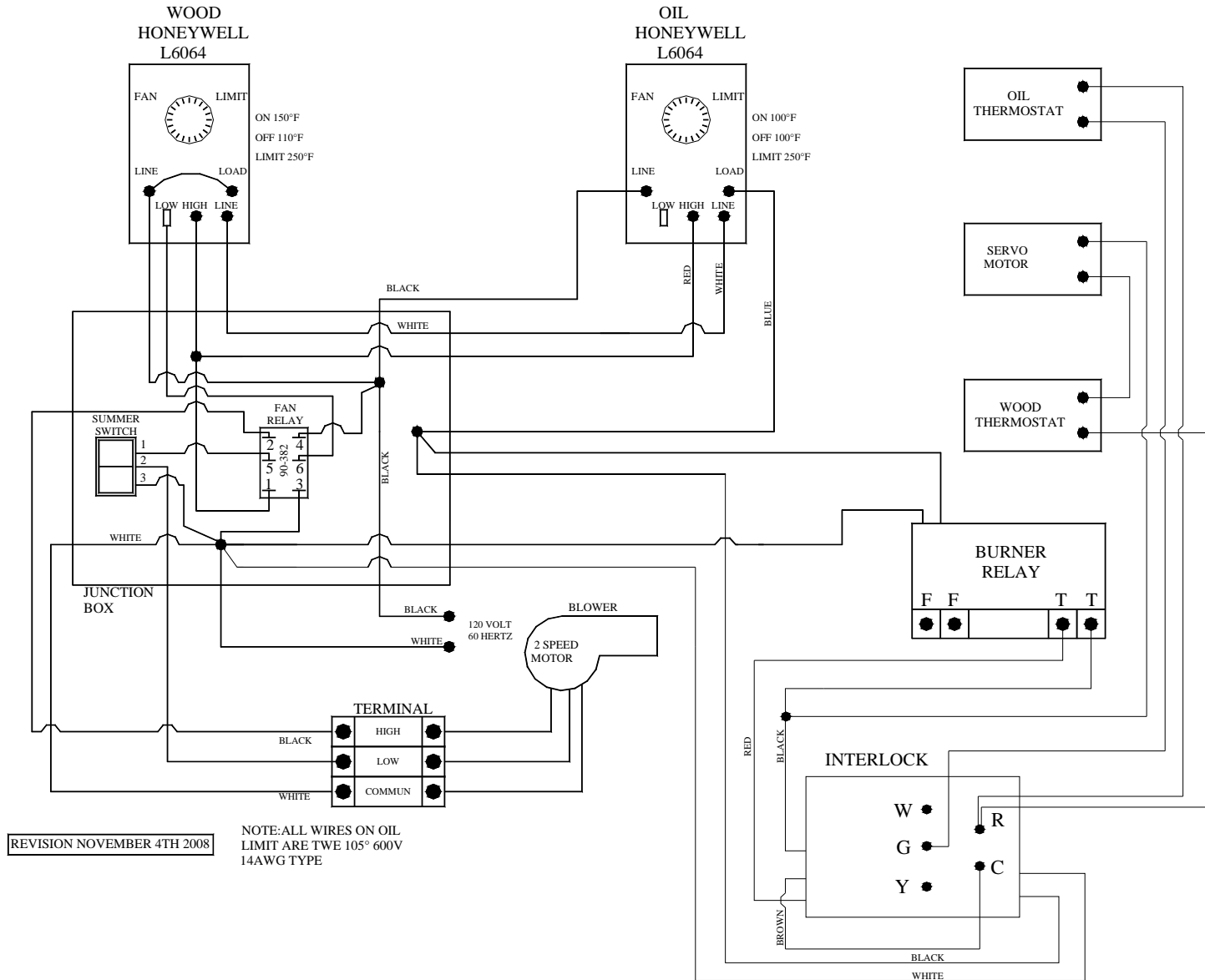

8- TECHNICAL DATA

PSG/UH – 2000 – 3000 – 4000 - 4500

MODEL	BURNER TYPE	BTU INPUT	NOZZLE	HEAD	STATIC PLATE	PRESSURE AT THE PUMP	H.P. MOTOR FAN
UH-2000	BECKETT AFG	85,000	0.65, 70° A (DELAVAN)	F3	2 3/4	110 PSI	1/3 H.P.
UH-3000	BECKETT AFG	91,000	0.65, 70° A (DELAVAN)	F3	2 3/4	120 PSI	1/3 H.P.
UH-4000	BECKETT AFG	120,000	0.75, 70° A (DELAVAN)	F3	2 3/4	150 PSI	1/3 H.P.
UH-4500	BECKETT AFG	150,000	1.0, 70° W (DELAVAN)	F3	2 3/4	120 PSI	3/4 H.P.

For any additional informations, consult the rating plate on the left hand side of the appliance.

PSG LIMITED LIFETIME WARRANTY

The warranty of the manufacturer extends only to the original consumer purchaser and is not transferable. This warranty covers brand new products only, which have not been altered, modified nor repaired since shipment from factory. Proof of purchase (dated bill of sale), model name and serial number must be supplied when making any warranty claim to your PSG dealer.

This warranty applies to normal residential use only. Damages caused by misuse, abuse, improper installation, lack of maintenance, over firing, negligence, accident during transportation, power failures, downdrafts, or venting problems are not covered by this warranty.

This warranty does not cover any scratch, corrosion, warping, or discoloration caused by over firing, abrasives or chemical cleaners. Any defect or damage caused by the use of unauthorized parts or others than original parts void this warranty. An authorized qualified technician must perform the installation in accordance with the instructions supplied with this product and all local and national building codes. Any service call related to an improper installation is not covered by this warranty.

The manufacturer may require that defective products be returned or that digital pictures be provided to support the claim. Returned products are to be shipped prepaid to the manufacturer for investigation. If a product is found to be defective, the manufacturer will repair or replace such defect. Transportation fees to ship the product back to the purchaser will be paid by the manufacturer. Repair work covered by the warranty, executed at the purchaser's domicile by an authorized qualified technician requires the prior approval of the manufacturer. Labour cost and repair work to the account of the manufacturer are based on predetermined rate schedule and must not exceed the wholesale price of the replacement part. All parts and labour costs covered by this warranty are limited according to the table below.

The manufacturer at its discretion may decide to repair or replace any part or unit after inspection and investigation of the defect. The manufacturer may, at its discretion, fully discharge all obligations with respect to this warranty by refunding the wholesale price of any warranted but defective parts. The manufacturer shall in no event be responsible for any special, indirect, consequential damages of any nature, which are in excess of the original purchase price of the product. A one-time replacement limit applies to all parts benefiting from lifetime coverage. This warranty applies to products purchased after March 1st, 2009.

DESCRIPTION	WARRANTY APPLICATION	
	PARTS	LABOUR
Castings, combustion chamber (welds only), castings, and heat exchanger (welds only).	Lifetime	3 years
Stainless steel firebox components, secondary air tubes*, surrounds and heat shields, ash drawer, and plating* (defective manufacture).	5 years	3 years
Carbon steel firebox components, glass retainers, handle assembly, C-Cast baffle*, and vermiculite baffle*.	3 years	1 year
Oil burner, electrical elements, blowers, heat sensors, switches, rheostat, relays, damper motor, fan limit control, PC board, wiring, and other controls.	2 years	1 year
Ceramic glass (thermal breakage only*), paint (peeling), gaskets, insulation, and ceramic fibre blankets.	1 year	n/a
Firebrick	n/a	n/a

**Pictures required*

Shall your unit or a components be defective, contact immediately your **PSG** dealer. Prior to your call make sure you have the following information necessary to your warranty claim treatment:

- Your name, address and telephone number;
- Bill of sale and dealer's name;
- Serial number and model name as indicated on the nameplate fixed to the back of your unit;
- Nature of the defect and any relevant information.
-

Before shipping your unit or defective component to our plant, you must obtain from your PSG dealer an Authorization Number. Any merchandise shipped to our plant without authorization will be refused automatically and returned to sender.