



**PSG**  
1700, Léon-Harmel  
Québec (Québec)  
G1N 4R9

## Installation and operating instructions for CADDY furnaces

READ THE MANUAL THOROUGHLY  
BEFORE OPERATING THE FURNACE

FURNACE MODELS INCLUDED IN THIS MANUAL

CADDY WOOD AND COMBINED  
15 Kw, 18 Kw, 20 Kw, 25 Kw and UH-Caddy

**Read these instructions carefully before installing  
and operating your furnace.**

### **CONGRATULATIONS!**

You have purchased one of the finest wood  
or combined furnaces available on the market.

We are confident that your furnace will provide years of comfort and safe  
operation.

**Please keep this document!**

# TABLE OF CONTENTS

<b>SECTION A: WOOD OR WOOD/ELECTRIC COMBINED FURNACES.....</b>	<b>3</b>
INTRODUCTION.....	3
1. CHIMNEY AND DRAFT.....	3
2. SAFETY RULES.....	3
<i>GENERAL REQUIREMENTS</i> .....	3
<i>ODOUR FROM THE PAINT</i> .....	4
<i>ASH DISPOSAL</i> .....	4
<i>CREOSOTE BUILD-UP AND REMOVAL</i> .....	4
<i>SMOKE DETECTOR</i> .....	5
<i>DOOR GLASS</i> .....	5
<i>GLASS SPECIFICATIONS</i> .....	5
<i>ASH DRAWER</i> .....	5
<i>ASH GRATE</i> .....	5
3. APPLIANCE INSTALLATION.....	6
<i>UNIT LOCATION</i> .....	6
<i>CLEARANCES TO COMBUSTIBLE MATERIALS</i> .....	6
<i>FLUE AND BAROMETRIC DAMPER CONNECTION</i> .....	7
<i>DAMPER</i> .....	8
<i>COMBUSTION AIR</i> .....	8
<i>PARALLEL INSTALLATION</i> .....	9
<i>ELECTRICAL CONNECTION</i> .....	10
<i>ELECTRIC ELEMENT CADDY WOOD / ELECTRIC</i> .....	11
<i>THERMOSTAT</i> .....	12
<i>FAN CONTROL</i> .....	12
4. OPERATING INSTRUCTIONS.....	12
<i>CONTROL SYSTEM</i> .....	12
<i>LIGHTING</i> .....	13
<i>PREHEATING</i> .....	13
<i>HEATING</i> .....	13
<i>EARLY SIGNS OF OVERFIRED FURNACE:</i> .....	14
<i>WOOD AS HEATING FUEL</i> .....	14
<i>CHIMNEY FIRES</i> .....	14
5. MAINTENANCE.....	15
<i>MAINTENANCE OF THE EXCHANGERS</i> .....	15
<i>CHIMNEY MAINTENANCE</i> .....	16
<i>MAINTENANCE OF THE BLOWER MOTOR</i> .....	16
<i>FILTERS</i> .....	16
<i>DOOR GASKET MAINTENANCE</i> .....	16
6. REPLACEMENT PARTS.....	17
<i>DOOR GLASS</i> .....	17
<i>GASKET</i> .....	17
7. WIRING DIAGRAM.....	18
<i>CADDY WOOD ONLY</i> .....	18
8. CADDY TECHNICAL DATA.....	19
<i>GENERAL TECHNICAL DATA</i> .....	19

<i>TECHNICAL DATA – ELECTRIC MODE</i> .....	19
9. DUCTS AND DAMPERS DIMENSIONS (EXAMPLES OF CALCULATION) .....	20
10. CADDY BRICKS LAYOUT.....	21
11. TROUBLE SHOOTING.....	22
<b>SECTION B: WOOD/OIL COMBINED FURNACES. ....</b>	<b>23</b>
GENERAL NOTES.....	24
1. DRAFT AND CHIMNEY .....	24
2. OIL TANK AND PIPING.....	24
<i>BURNER PUMP</i> .....	25
3. APPLIANCE INSTALLATION.....	25
<i>LOCATING THE UNIT</i> .....	25
<i>CLEARANCES TO COMBUSTIBLE MATERIALS</i> .....	25
<i>POSITIONING THE APPLIANCE</i> .....	28
<i>PIPE CONNECTOR AND DAMPER</i> .....	28
<i>COMBUSTION AIR</i> .....	29
<i>ELECTRIC COMPONENTS INSTALLATION</i> .....	30
<i>ELECTRICAL WIRING</i> .....	31
<i>THERMOSTAT</i> .....	31
<i>FAN CONTROL</i> .....	31
<i>COMBUSTION SAFETY CONTROL</i> .....	32
<i>COMBUSTION ADJUSTMENT AND VERIFICATION</i> .....	32
<i>ELECTRODES SETTING</i> .....	33
4- APPLIANCE START-UP .....	34
5- PROLONGED CLOSING.....	34
6- MAINTENANCE.....	34
<i>SERVICE</i> .....	34
<i>MAINTENANCE</i> .....	35
<i>FILTERS</i> .....	35
7- ELECTRICAL DIAGRAMS.....	36
8- TECHNICAL DATA.....	37
PSG LIMITED LIFETIME WARRANTY .....	38

**REGISTER YOUR WARRANTY ONLINE**

To receive full warranty coverage, you will need to show evidence of the date you purchased your stove. Keep your sales invoice. We also recommend that you register your warranty online at [www.psg-distribution.com](http://www.psg-distribution.com)  
Registering your warranty online will help us track rapidly the information we need on your furnace.

# SECTION A: WOOD OR WOOD/ELECTRIC COMBINED FURNACES.

## INTRODUCTION

Take note that this furnace operates like an EPA wood burning stove. This applies to the lighting, the embers and the minimum combustion air intake which depends on the type and the grade of the combustible.

This model line is certified as meeting the emissions limits in 40 C.F.R. part 60, section 60.532 (B) per EPA methods 28 and 5G-3, February 1988.

Average emissions rate: 6.56 g/hr  
Average heating efficiency: 76%

To optimize the efficiency of your furnace, here are few advices you should follow when installing or operating your Caddy

Respect the local codes (when in doubt, consult your local dealer).

Make sure your furnace is installed according to the instructions on the certification plate.

All controls adjustments must be performed by a qualified technician. The controls settings and the blower speed must conform to the recommendations of the National Warm Air Heating and Air Conditioning Association and respect the recommended static pressure ranges in the warm air bonnet of the furnace (see General Technical data static pressure).

## 1. CHIMNEY AND DRAFT

This furnace must be connected to a chimney certified for use with wood burning heating appliances; a 7 inch chimney and connector are recommended for the Caddy (see 3.Appliance installation, paragraph C).

If draft exceed  $-0.06$  in. W.C a barometric damper should be installed on the smoke pipe.  
Never install a manual damper.

The barometric control must be adjusted so that the maximum draft measured at the furnace outlet does not exceed  $-0.06$  in. w.c. Please note that a draft exceeding  $-0.06$  in. w.c. will reduce the efficiency and could produce an uncontrollable fire. **On the other hand, the minimum draft required is  $-0.04$  in. w.c. in the evacuation pipe on the wood side, no matter what type of furnace (WOOD, WOOD / ELECTRIC OR WOOD / OIL).**

## 2. SAFETY RULES

### GENERAL REQUIREMENTS

- Make sure the chimney outlet and the pipes are clean and in good condition.
- Do not use chemical products or liquids to light the fire.
- Do not burn wood coated with paint, glue or chemical products.
- Do not burn wastes or flammable liquids such as gasoline, naphtha or motor oil.
- Do not install an automatic feeder on this furnace.
- Do not store wood in the vicinity of the furnace. Respect the required clearances between combustible materials and the source of heat.

## **WARNING**

- THE ASH DRAWER AND EXCHANGERS ACCESS PANEL GET VERY HOT.
- DO NOT MANIPULATE WITH BARE HANDS.

### **ODOUR FROM THE PAINT**

It is normal that smoke and odours emanate from the unit when you first light it. It is recommended to burn it at high rate and ventilate the building until the odours resorb.

### **ASH DISPOSAL**

Ashes must be placed in a metal container with a tight fitting lid. The container should be stored outdoors, well away from combustible materials. If the ashes are meant to be buried in soil, wait until all cinders have thoroughly cooled before burying.

### **CREOSOTE BUILD-UP AND REMOVAL**

When wood is burned slowly, it produces tar and other organic vapours which, when combined with moisture, form creosote. The creosote vapours condensate in a relatively cool chimney flue. As a result, creosote residues accumulate on the flue lining.

N.B.: To minimize the frequency of the chimney cleaning, buy your firewood at least one year before using it. Store it in a dry place in order to obtain the minimum moisture rate and optimize the efficiency. Do not store wood or combustible materials within the installation minimum clearances or the space required to reload the appliance and remove the ashes.

When ignited, creosote produces an extremely hot fire inside the chimney.

To avoid chimney fires, it is important to do the turnover of wood. Inspect the chimney system at regular intervals to determine a cleaning cycle. A weekly cleaning might be required during mild temperature periods while a monthly cleaning should be sufficient during colder periods.

**If a significant layer of creosote has accumulated, it must be removed immediately to eliminate the risk of chimney fire.**

Remember that a small hot fire is preferable to a large smouldering one to prevent creosote build-ups within the system. Prepare an emergency procedure in case of a chimney fire.

**It's recommended to clean the heat exchangers thoroughly at the end of season in order to prevent corrosion.**

## **SMOKE DETECTOR**

We highly recommend the use of a smoke detector. It must be installed at least 15 feet (4,57 m) from the appliance in order to prevent undue triggering of the detector when reloading.

## **DOOR GLASS**

To maintain a clean and safe installation, do not build your fire too close to the glass or allow the fire logs to lean on the glass.

Do not operate your furnace at too low a setting. Keep the air inlet opened long enough during the fire start-up to prevent the fire from smouldering, which could stain the glass.

An intense fire will help keeping the glass clean. However, in the event that your glass gets stained, which should normally not occur, you will have to clean it using a wet cloth and an oven cleaner. Cleaned the glass **ONLY** when the unit has cooled down. Do not use abrasive cleanser. Wood stove glass cleaners are available on the market and their efficiency makes no doubt.

**WARNING: Avoid knocking or scratching the glass which could crack or break.**

## **GLASS SPECIFICATIONS**

The glass is made of Pyroceram type of glass, 3/16" – (5 mm) thick.

Do not operate your furnace with a broken glass, as this could seriously damage your furnace.

You can purchase a replacement glass from your PSG dealer.

## **ASH DRAWER**

Your furnace is equipped with an ash drawer to collect ashes produced by the combustion of wood. This drawer must not be left open during combustion as this may cause over firing and serious damages to the furnace.

**The drawer must be cleaned regularly.**

It is important that the door and the ash drawer be kept closed while the appliance is in use. Maintain all gaskets in good condition; in case of deterioration, contact your dealer for replacement gasket.

## **ASH GRATE**

You must replace the ash grate if it is damaged and a replacement may be obtained from your dealer. The steel plate on the ash grid is meant to optimize the heat inside the combustion chamber and should only be removed to empty the ashes.

### 3. APPLIANCE INSTALLATION

#### UNIT LOCATION

The furnace must be installed where outside air supply is sufficient for proper combustion. In airtight houses, it might be necessary to install an outside air inlet (see details in: COMBUSTION AIR).

The furnace must be positioned so that the connector is as short as possible; minimize the use of 90° elbows.

The owner must ensure a proper installation to allow a safe operation of the appliance.

#### CLEARANCES TO COMBUSTIBLE MATERIALS

**N.B.** This appliance must be installed according to the instructions on the unit's certification plate.

#### MINIMUM CLEARANCES TO COMBUSTIBLE MATERIALS FOR CADDY FURNACE

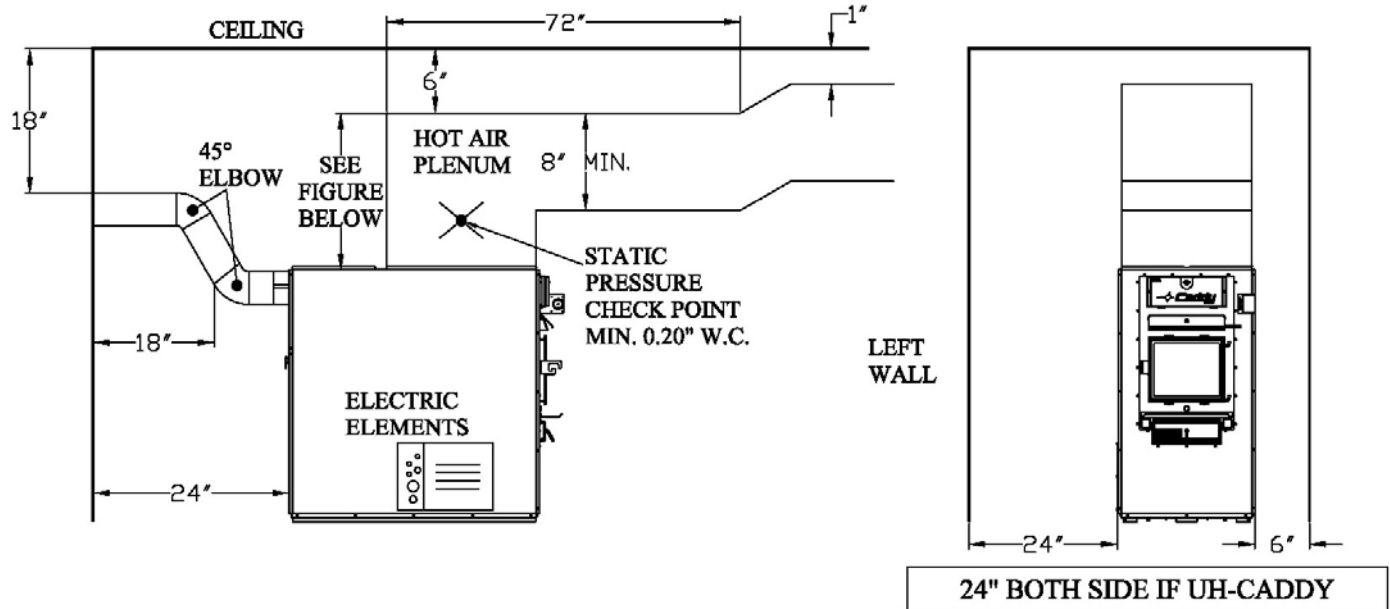

**N.B.** THE SIZE OF THE AIR RETURN CONDUITS SHOULD BE AT LEAST EQUAL TO THE SIZE OF THE COLD AIR PLENUM OPENING.

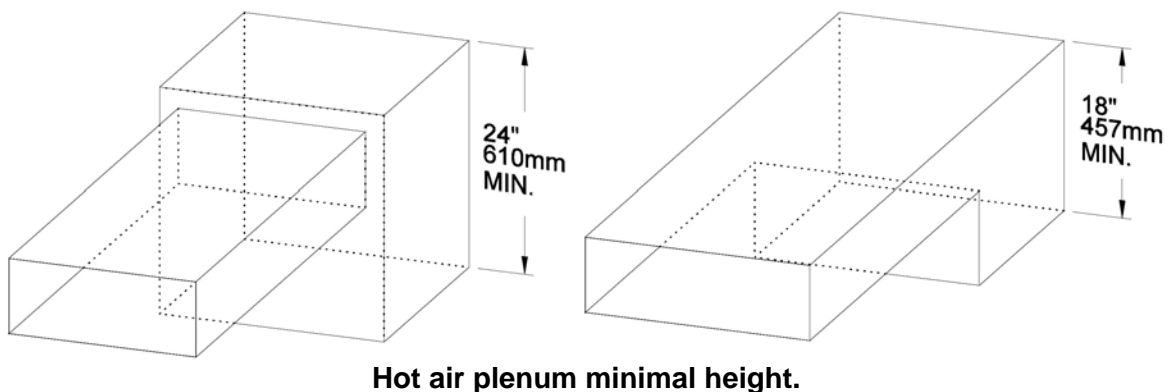

## FLUE AND BAROMETRIC DAMPER CONNECTION

**Before connecting the stove pipe, make sure you have removed the accessories from the flue pipe as the scraper, shovel and the poker.**

The flue outlet on the Caddy furnace is 6" in diameter and the wood only or wood/electric models may be installed with a 6" chimney approved for use with wood burning heating appliances (2100°F). However, we recommend the use of a 7" chimney to allow the retrofit to wood/oil configuration, if desired, without changing the chimney; in that case, a 6" to 7" reducer must be installed at the flue outlet of the furnace. If the draft exceed -0.06 w.c., a barometric control must installed.(see **Damper**) **Never install a manual damper.**

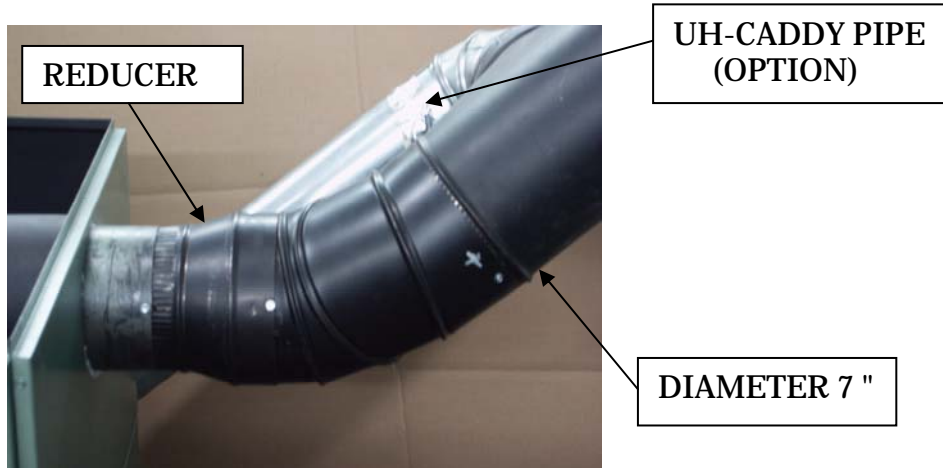

For a proper installation, follow the advices below:

1. All the evacuation pipe joints must be secured with three screws.  
***Make sure that each screw goes through the inner walls of both connectors (male and female). See pictures below showing a male-female coupling.***

PROPER INSTALLATION



IMPROPER INSTALLATION



CAUSE RESTRICTION

2. A minimum rise of 1/4 inch per horizontal foot must be respected.

## DAMPER

If the draft exceeds -0.06 w.c., a barometric damper must be installed. The barometric damper must be adjusted so that the maximum draft measured at the furnace outlet is limited to -0.06 in. w.c. Please note that a draft higher than -0.06 w.c. will reduce efficiency and could result in an uncontrollable fire. **On the other hand, the minimum draft to be respected is -0.04 in. w.c. in the evacuation pipe on the solid fuel side, no matter what type of furnace (WOOD, WOOD / ELECTRIC OR WOOD / OIL).**

## COMBUSTION AIR

When the furnace and the chimney are completely cold, it might be necessary to provide fresh air by opening a door or a window for a few minutes while lighting the fire.

Take note that a house constructed or renovated in order to be airtight is liable to lack fresh air necessary for the proper combustion of a flame producing heating appliance.

In such a case, when starting up the fire, do not operate appliances which evacuate air outside the house such as:

- Range hood
- Air exchanger
- Clothes dryer
- Bathroom fan
- Ventilated central vacuum system

## NOTE:

It is recommended to install an outside air inlet of minimum 4" diameter in the room where the heating appliance is installed (see drawing below). It is preferable to choose a wall which is not exposed to dominant winds, depending on the conditions surrounding your house.

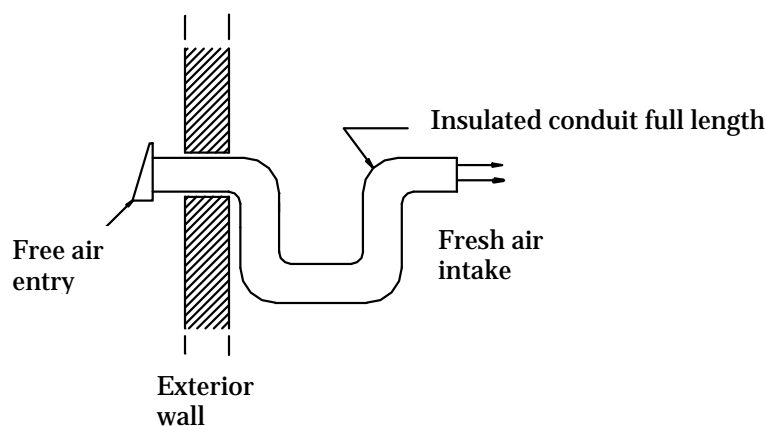

**N.B. The owner of the furnace is responsible for the room salubrity in case of negative pressure or temporary negative pressure.**

## Parallel Installation

The installation of this furnace with another furnace using the same ductwork is not allowed in Canada. **This type of installation is only allowed in the United States.** Ideally, the maximum BTU input of the existing oil, gas, or electric furnace should be equal or higher than the maximum BTU input of the wood furnace. It is mandatory to respect minimum clearances between the ductwork and combustible material as if the wood furnace was installed as a standalone unit. The ductwork and furnace should be adjusted in order to reach a static pressure of at least 0.20 IN.WC, but not more than 0.50 IN.WC. A back-flow damper should be installed in the plenum. The back-flow damper assures that when either unit is operated by itself, the hot air will flow into the home, and not back through the other furnace. Depending on your installation (see figures examples below), a back-flow damper may be required in each plenum.

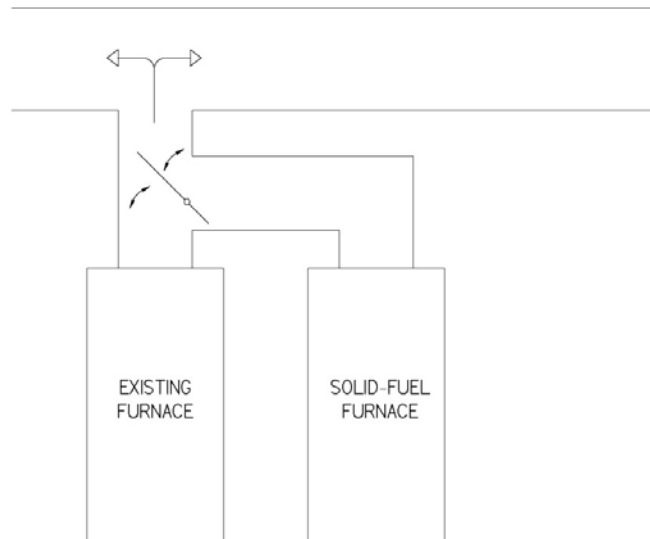
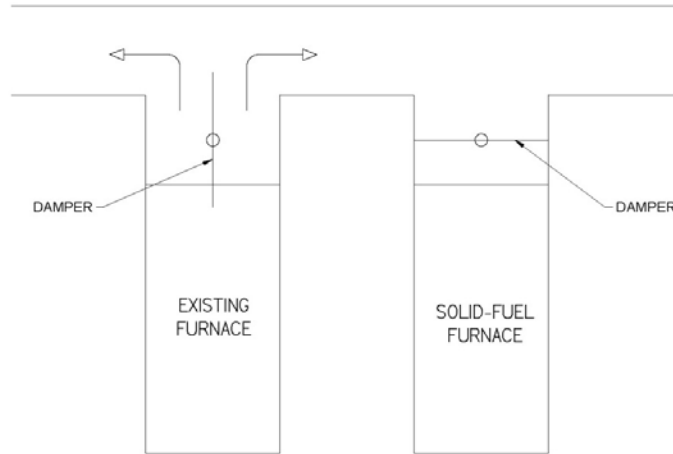

## ELECTRICAL CONNECTION

The following instructions do not supersede the local code.

### CADDY-WOOD ONLY

On the wood Caddy, the fan limit control is installed with the support provided, on the left side of the appliance, (four holes are pre-drilled on the edge of the furnace, use the two that are closer to the front of the furnace), and connected to the electrical box along with the transformer. Install the damper motor on the right side of the facade, above the door (use the pre-drilled holes). The chain that links the air inlet damper to the motor must have a play of 1/8 in. When there is no call for heat, the air inlet damper must be completely closed and the chain must be hooked to the servo-motor at the “8 o'clock” position. \*

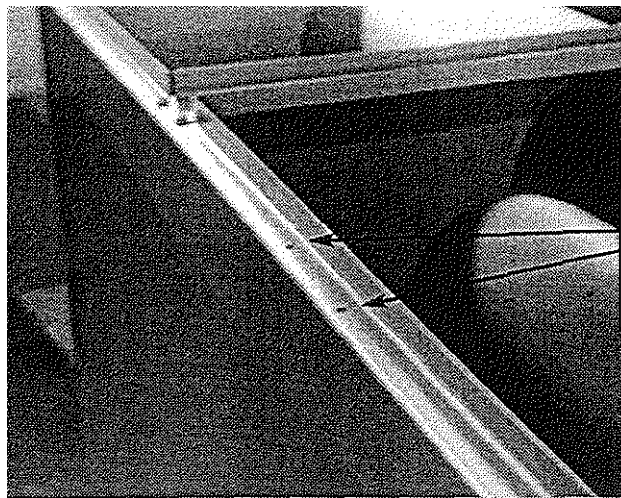

HOLES TO  
SECURE FAN  
LIMIT BRACKET

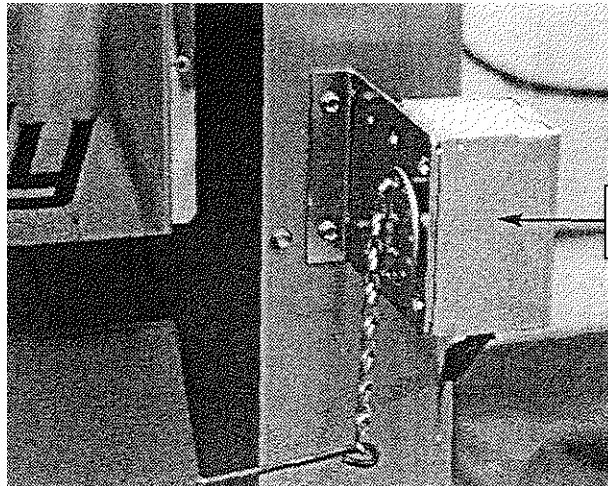

SERVOMOTOR

**WARNING: USE WIRING SUITABLE FOR 75° C**

## CADDY WOOD/ELECTRIC

The high limit control is a manual reset thermostatic captor that is located inside the electric unit (see **WIRING DIAGRAMS**). The electric unit must be connected as shown on the diagram. Install the wood fan limit control on the support provided, at the determined location. The connections must conform to the diagram.

Install the damper with the bracket included at the right location. Install the damper motor on the right side of the façade above the door (use the pre-drilled holes). The chain that links the air inlet damper to the motor must have a play of 1/8 in. When there is no call for heat, the air inlet damper must be completely closed and the chain must be affixed to the damper motor at the “8 o'clock” position. \*

### **WARNING: USE WIRING SUITABLE FOR 75° C**

- \* (With all reserves on the minimum combustion air to be increased depending on the type and quality of the combustible).

## ELECTRIC ELEMENT CADDY WOOD / ELECTRIC

The WOOD / ELECTRIC combined model uses two thermostats: one thermostat controls the electric heating, the other one controls the wood heating. With this system, the electric heating has priority over the wood heating. When the thermostat activates the electric heating, the air inlet damper closes down (if opened), the blower starts and the electric elements are successively activated per block of 5 kW. The system may be equipped with an outdoor sensor (not included) which will allow the last block of elements (5 kW) to start up only when the outside temperature is cold enough. This will reduce the power of the systems by 5 kW during mild temperature for more comfort and economy.

When the call for electric heating is satisfied, the wood system will take over if the starting point of the wood system thermostat is superior to that of the electric system so, in normal bi-energy use, you should set the wood system thermostat 2° to 3° C. higher than the electric system thermostat; the bigger the gap, the more the wood heating will contribute to the overall heating needs.

Take note that this furnace is equipped with a four speed blower motor. Aside from low speed, you may select medium-low, medium-high or high speed.

If the temperature of the electric unit exceeds the high limit , the thermostatic captor will disengage the elements. To reactivate, press the red “manual reset” button on the thermostatic captor ( L-170 Thermodisc) after finding and fixing the problem that has caused the unit to overheat (static pressure too high, fan breakdown, etc.)

### **INSIDE VIEW OF THE ELECTRIC ELEMENT**

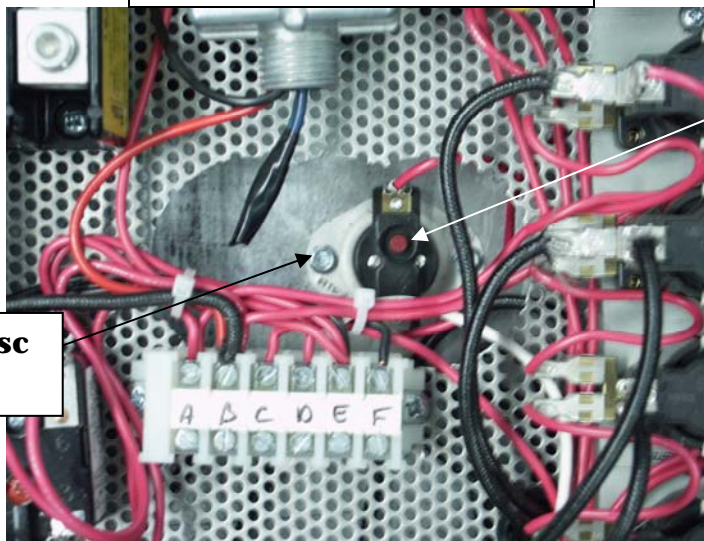

**Red button  
manual reset**

**L-170 Thermodisc  
RESET**

## OUTSIDE VIEW OF THE ELECTRIC ELEMENT

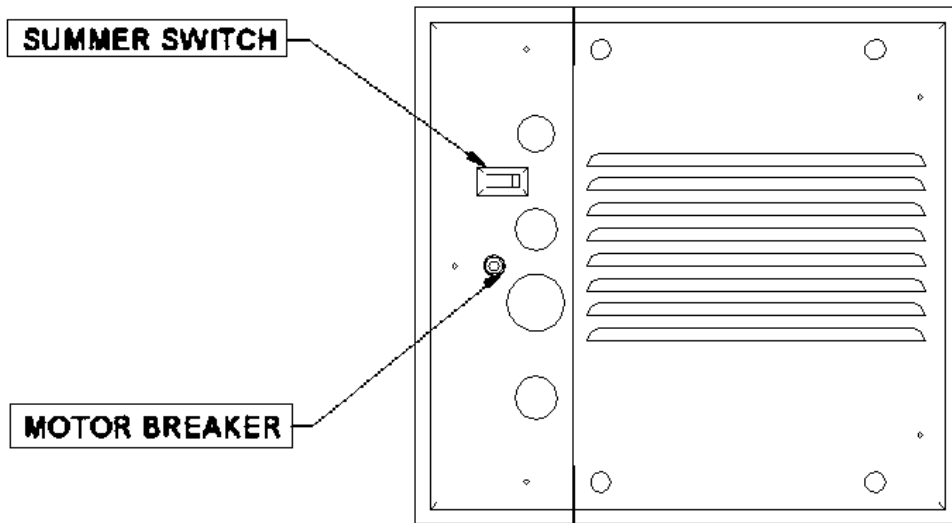

### THERMOSTAT

The thermostat must be installed on an inside wall in a location where it is not likely to be affected by the draft coming from an air outlet. It must be installed at a minimum of 55 inches above the floor.

N.B. Both thermostats used on the combined wood / electric model should be installed at same height.

### FAN CONTROL

The fan limit control setting may vary depending on the type of installation. The temperature setting "out of service" is preset at 110° F, the temperature setting "in service" at 150° F. and the high limit at 250° F at the factory. These settings should provide a proper operation for most installations.

It is preferable, for a prolonged operation of the blower, that the setting "out of service" be low enough. But a setting "out of service" too low will cause undesirable cold air circulation. To modify the settings, simply move the tabs to the desired position on the temperature dial of the fan limit control.

The adjustment of all controls must be performed by a qualified technician. The controls setting and the blower speed must conform to the recommendations of the "Warm Air Heating and Air Conditioning National Association". For continuous operation of the blower, use the switch located below the fan limit control or on the electric unit which controls the low speed either at the "on" position or the "off" position.

It is not recommended to let the blower run on continuous mode when heating with wood since the wood furnace must reach a certain temperature before the blower starts in order to operate efficiently.

## 4. OPERATING INSTRUCTIONS

### CONTROL SYSTEM

On the wood furnaces only, the thermostat controls the air inlet damper. When the thermostat calls for heat, the damper opens and the fire stirs up. When the furnace gets hot enough, the combined limit control activates the blower motor at the speed selected for wood heating.

The chain that links the air inlet damper to the motor must have a play of 1/8 inch. When there is no call for heat, the air inlet damper must be completely closed and the chain must be affixed to the damper motor at the "8 o'clock" position. \*

\* (With all reserve on the minimum air to be increased depending on the type and quality of the combustible).

## LIGHTING

1. Open the door

**Note: In the case that there is a bed of coals in the bottom of the furnace, go to Pre-heating.**

2. Remove the steel plate on the ash grid and dump the ashes in the ash drawer.
3. Put the steel plate back in place, making sure it is properly seated. The steel plate on the ash grid is intended to optimize the heat retention into the combustion chamber.
4. Place one or two dry kindlings at the front of the furnace.
5. Place newspaper strips on top of the kindlings.
6. Cover the newspaper with more kindlings and small pieces of dry wood.
7. Add newspaper strips, then light the fire as low as possible and leave the door 1/2" (13 mm) opened. If you fail lighting the fire, you might experience a back draft through the air inlets.

## PREHEATING

1. Once the kindling is well ignited or the coals revived, put 2 or 3 fire logs in such a way that the flames can interlace between the logs then close the door. It is important to respect these loading sequences so that the wood will burn from the front to the back of the furnace.
2. Wait 15 to 20 minutes, then proceed with loading the furnace.

## HEATING

1. When loading the furnace, lower the kindled pieces of wood and place them at the center of the combustion chamber before adding new logs.
2. Do not overload. Air must circulate freely in the upper part of the combustion chamber in order to obtain an efficient operation of the appliance. Please note that a small hot fire will produce much less residues than a large smouldering one.

**IMPORTANT: DURING THE HEATING PROCESS, REMOVE THE ASHES AND WOOD THAT COULD OBSTRUCT THE 1/4" (6.4 mm) HOLE LOCATED BELOW THE DOOR INSIDE THE FURNACE.**

### **PROCEDURE TO OPEN THE LOADING DOOR**

TO MINIMIZE THE RISK OF SMOKE SPILLAGE, OPEN THE DOOR 1" AND WAIT ABOUT 10 SECONDS BEFORE OPENING COMPLETELY. THE PURPOSE IS TO STABILIZE THE PRESSURE INSIDE THE FURNACE.

## **Prolonged power failure**

At the time of a prolonged power failure, you can still use your furnace. The air intake register remains in closed position and the furnace functions at the minimal combustion mode. It is very important to ensure that the holes located under the loading door inside the furnace are free to ensure a good performance (small holes of 1/4").

## EARLY SIGNS OF OVERFIRED FURNACE:

1. Roaring fire.
2. Chimney connector is glowing red.
3. Extreme heat coming from the furnace. If this occurs, **DO NOT OPEN THE DOOR**, shut-off the air inlet opening completely, and wait until the glow has completely subsided.

**ALWAYS KEEP THE DOOR AND THE ASH DRAWER CLOSED**  
**(except for lighting and maintenance).**

## WOOD AS HEATING FUEL

We recommend that you burn dry hard wood only.

There are two important factors to be considered when choosing a type of wood: the moisture content and the wood density. Hardwood, such as maple, oak and beech will provide better results because of the high density and minimal tar produced during combustion. It is highly recommended to use wood that has been dried at least six months. **Do not use coal as heating fuel in this appliance.**

Whenever a high rate of smoke is noticed in the room, you must:

1. Open doors and windows.
2. Make sure the furnace door is closed as well as the damper (if necessary, lower the thermostat starting point or unhook the damper chain and close the barometric draft control manually).
3. When the furnace has cooled down, inspect the chimney to detect obstructions and consult a specialist to determine the cause of the smoke spillage.

## **CARBON MONOXYDE IS A LETHAL GAS (ODOURLESS AND COLOURLESS), WHICH YOU MUST BEWARE OF.**

## CHIMNEY FIRES

This might occur when the fire gets extremely hot. Burning cardboard, branches or small pieces of wood can ignite the creosote residue accumulated in the evacuation flue system. The usual signs are:

1. Rumbling
2. The flue gets extremely hot
3. Flames or sparks are coming out of the chimney

***In case of a chimney fire, call your local fire department immediately and sprinkle the roof around the chimney with water.***

Make sure that the furnace door is closed as well as the damper (if necessary, lower the thermostat starting point or release the chain from the damper and **CLOSE** the barometric draft control manually).

If the fire gets uncontrollable due to an improper use or because the draft is too strong, follow the same procedure as in a chimney fire except that you will have to **OPEN** the barometric draft control manually.

## **LOCAL FIRE DEPARTMENT.**

Phone number: \_\_\_\_\_

## 5. MAINTENANCE

### MAINTENANCE OF THE EXCHANGERS

The evacuation pipe and the exchangers should be inspected regularly during the burning season. Easy access is provided (without the use of tools): simply unscrew the wing nut on the exchangers access door. See pictures below.

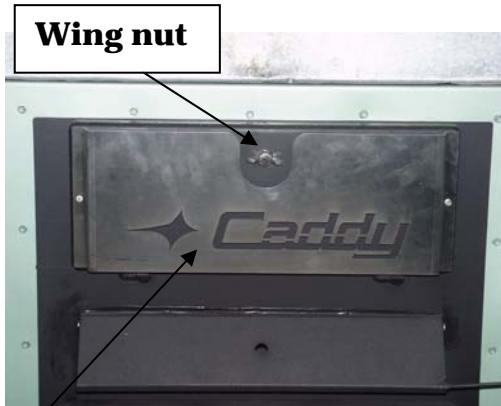

**Exchangers cover**

Before cleaning the three exchanger pipes, move the upper plate of the combustion chamber forward (see drawing on next page). Using the scraper, clean the three exchanger pipes. The accumulated dirt in the lateral exchangers will fall into the combustion chamber; the dirt in the central exchanger will have to be removed from the front or the back of the furnace. Then, ensure that the upper plate is free of ashes. **Do not forget to push the upper plate back to its original position.** Finally, close the exchanger access door.

**CADDY  
SECTION VIEW**

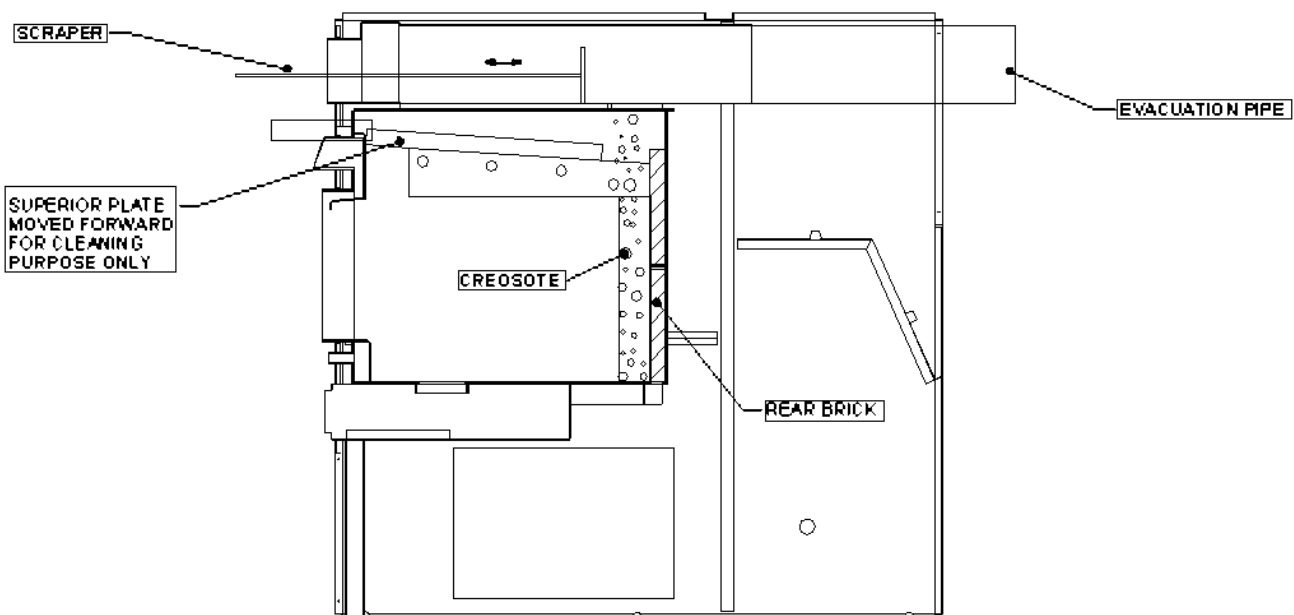

## **CHIMNEY MAINTENANCE**

The most efficient method to sweep the chimney is using a hard brush. Brush downwards so soot and creosote residues will come off the inner surface and fall at the bottom of the chimney where they can be removed easily.

The chimney must be checked regularly and if creosote has accumulated, it must be removed without delay. Cleaning on a monthly basis should be sufficient during the coldest months.

### **Smoke flue inspection**

- The smoke flue should be inspected regularly during the heating season.
- If possible, the smoke flue should be dismantled and cleaned.
- The flue should be inspected for possible damage.
- If it is in good condition, put the flue back in place; otherwise, it must be replaced.
- Use only wood as a combustible.
- Seasoned hard wood logs 18" to 22" long are recommended as combustible.

## **MAINTENANCE OF THE BLOWER MOTOR**

The two motor bearings must be lubricated once a year using non detergent SAE 20 oil.

**DO NOT OVERLUBRICATE**

## **FILTERS**

The furnace must not be operated without filters. In order to efficiently and safely operate a slow combustion heating system, you have to ensure a regular maintenance. This means that the chimney, the joints and the flue must be kept in good condition and the air filters must be replaced regularly; use the same size and same type as the original filters.

### **Filters dimensions**

Caddy: 12" x 24" filters, part #21039

## **DOOR GASKET MAINTENANCE**

It is important to maintain the door gasket in good condition. After a while, the gasket might sag; a door adjustment may then be required. If the door adjustment is not sufficient, replace the door gasket.(see 6-Gasket)

Door adjustment procedure:

1. Unscrew completely the locking pin (see picture below).

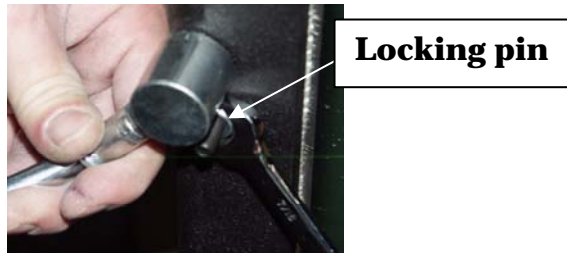

2. To increase the pressure of the door on the gasket, turn the handle counter clockwise; to decrease the pressure of the door on the gasket, turn the handle clockwise until desired pressure is attained.
3. Then screw back the locking pin about 1/4" deep and make sure you lock it in place with the nut.

## 6. REPLACEMENT PARTS

Your PSG furnace is designed to burn clean and requires little maintenance. It's recommended to conduct a visual inspection at least once a month to uncover any damage to the unit. Any defect must be repaired without delay using genuine PSG replacement parts. You can find a complete list of replacement parts in our website at [www.psg-distribution.com](http://www.psg-distribution.com).

### DOOR GLASS

- Inspect the glass regularly to detect any glass failure. If you find any defect, stop using the furnace immediately. Never operate a wood furnace with a broken glass.
- If you have to change your door glass, you must use Pyroceram 3/16" (5mm) thick. Use genuine parts sold by a PSG authorized dealer.
- To replace the glass, remove the screws that hold the glass retainers in place. Removed these retainers and replace the defective glass; the glass gasket should be replaced at the same time. To put back in place, reverse the procedure.
- Do not use abrasive cleanser. Special cleansers for wood stoves glass are available in any good hardware store.
- Clean glass **ONLY** when the unit has cooled down.

### GASKET

We recommend to replace gasket that seals the door once a year, in order to maintain a good control of the combustion for maximum efficiency and security. To replace your door gasket, remove the old gasket and glue. Clean the surface thoroughly, apply glue sold for that particular use, and put the new gasket onto the door. Wait for at least 2 hours before lighting your furnace.

# 7. WIRING DIAGRAM

## CADDY WOOD ONLY

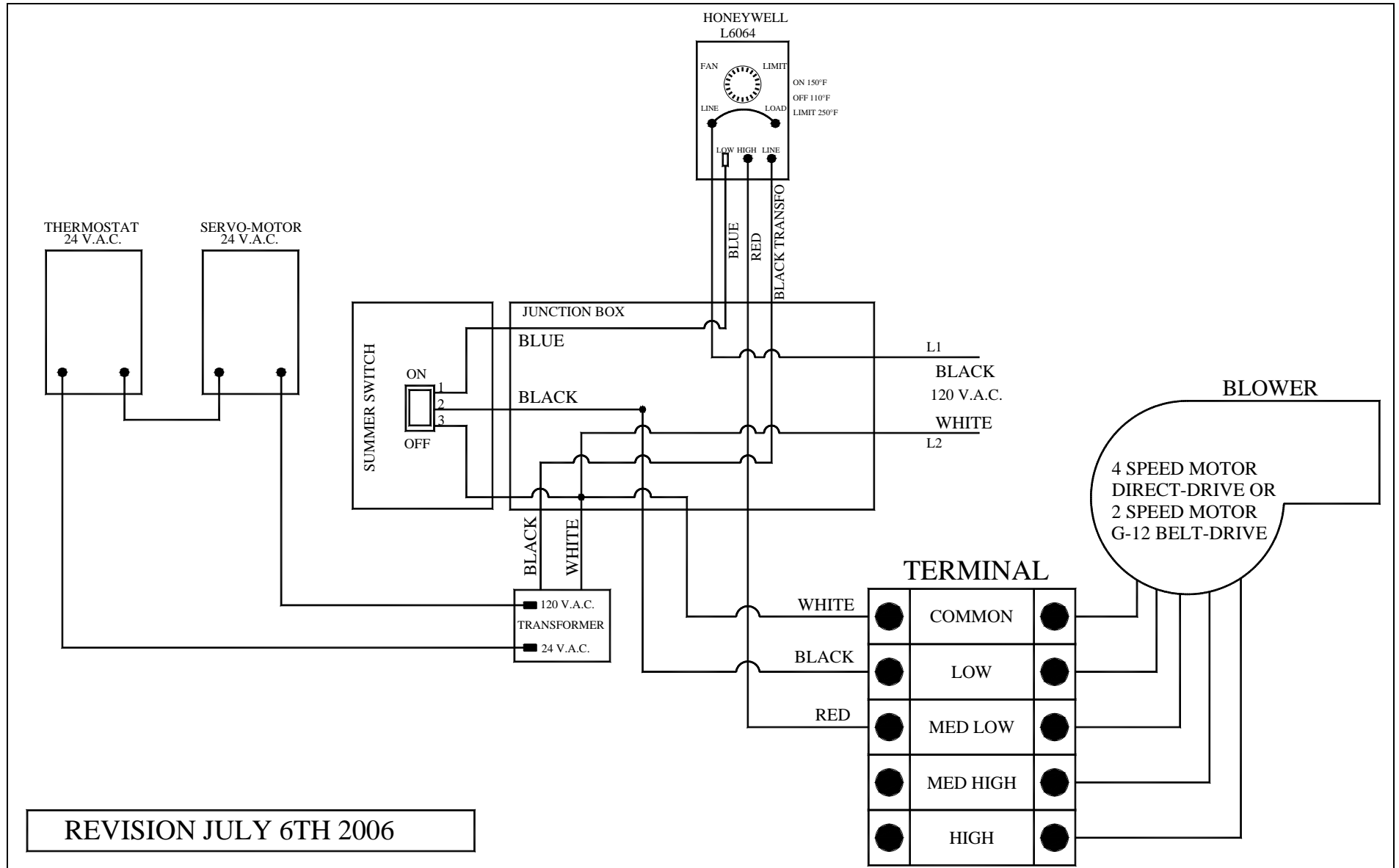

## 8. CADDY TECHNICAL DATA

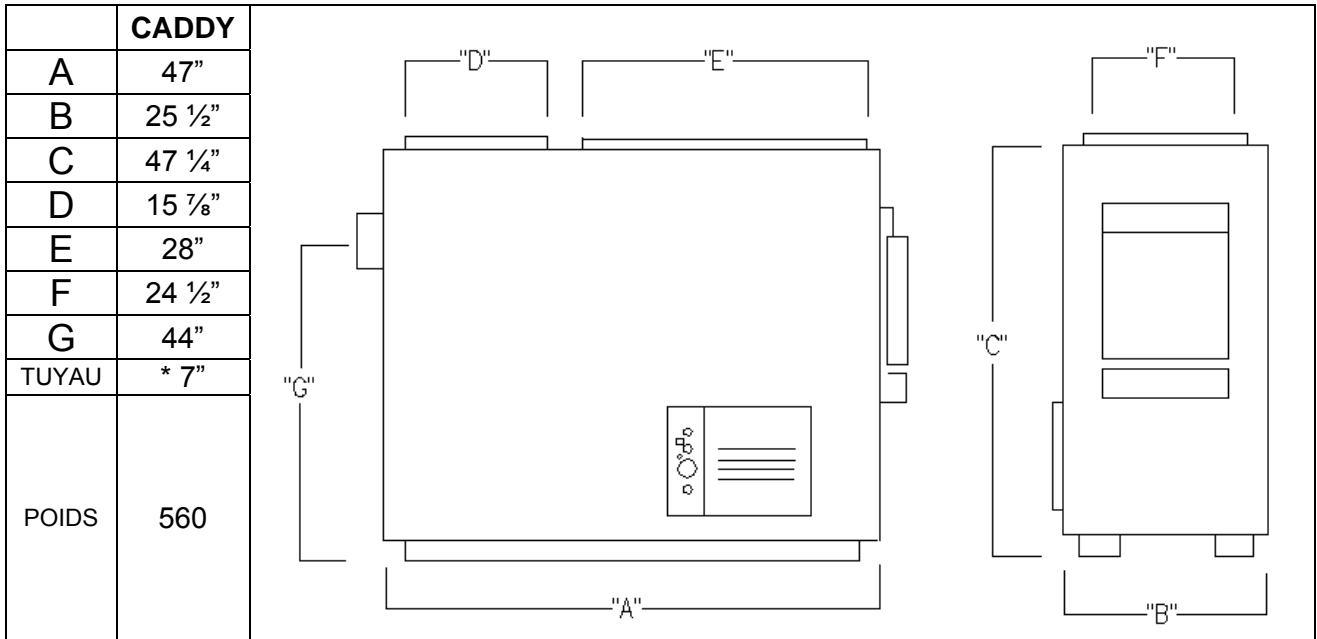

\* Reducer required

## GENERAL TECHNICAL DATA

MODEL	DIRECT DRIVE			OUTPUT (CFM)	TEMP. VAR. (° F)	BTU INPUT (WOOD)	STATIC PRESSURE		FILTER (2)
	FAN	MOTOR	SPEED				MIN.	MAX.	
							H <sub>2</sub> O		
CADDY	DD-10	1/3	4	1300	78	140000	0,2	0,6	12" x 24" X 1"

## TECHNICAL DATA – ELECTRIC MODE

MODEL	OUTPUT (CFM)	TEMP. VAR. (° F)	BTU/HR	AMPERES TOTAL	BREAKER REQUIRED	FEEDER GAUGE	VOLTAGE SINGLE PHASE	ELEMENTS QTY
15 KW	950	50	51195	75	100	4	120/240	3 – 5 KW
	1300	36						
18 KW	950	60	61434	87	125	4	120/240	2 – 5 KW, 2 – 4 KW
	1300	44						
20 KW	950	67	68260	95	125	3	120/240	4 – 5 KW
	1300	49						
25 KW	950	83	85325	115	150	2	120/240	5 – 5 KW
	1300	61						
WOOD	1800	44		15			120	

## 9. DUCTS AND DAMPERS DIMENSIONS (EXAMPLES OF CALCULATION)

### SIMPLIFIED METHOD DISTRIBUTION SYSTEM

Ducts size (heat)

4 inch outlet	reduce by 1"	
5 inch outlet	reduce by 2"	Always by 8" thick
6 inch outlet	reduce by 3"	

**N.B.: The main duct must be reduced every 2 outlets.**

---

Ducts specifications (heat)

Dimensions	Length	Elbow	Average equivalence
4"	10'	1 x 90°	Max 4,000 Btu
5"	10'	1 x 90°	Max 6,000 Btu
6"	10'	1 x 90°	Max 7,000 Btu

---

### DAMPER

For a 4" warm air outlet: 2" x 10" damper

For a 5" warm air outlet: 2" x 12" damper or 4" x 10"

For a 6" warm air outlet: 2" x 14" damper or 4" x 12"

### WARM AIR SYSTEM INSTALLATION

HOUSE DIMENSIONS

Example: 28 x 40 bungalow: 1,120 sq. ft.

28 x 40 x 8: 8,960 cu. ft. x 1.8 Ch. air/hr: 16,128 Btu

**Exposed walls:**

40 + 40 + 28 + 28: 136 x 8: 1,088 cu. ft. x 22: 23,936 Btu

**Number of windows:**

12 of 3 x 4: 144 x 60: 8,640 Btu

**Number of doors:**

2 x 3 x 7: 42 x 100: 4,200 Btu

52,904 Btu

**Non-insulated basement: 25%**

**Insulated basement: 15%** 7,906 Btu

**or 54 Btu per sq. ft.** 60,840 Btu

FOR ELECTRIC ELEMENTS 80%: 48,672 Btu or 14,28 kW

TO BE ADDED: House 1 1/2 floor = 25%  
House 2 floors = 40%

---

BEDROOM (for example: 12 x 12)

12 x 12 x 8: 1,152 cu. ft. x 1.8 Ch. air/hr: 2,074 Btu

**Exposed walls:**

12 + 12 x 8: 192 x 22: 4,224 Btu

**Windows:**

3 x 4 x 60 720 Btu

7,018 Btu

## 10. CADDY BRICKS LAYOUT

WARNING: INSTALL THE CERAMIC BLANKET PANEL BEFORE  
PUTTING BRICKS UP IN THE COMBUSTION CHAMBER

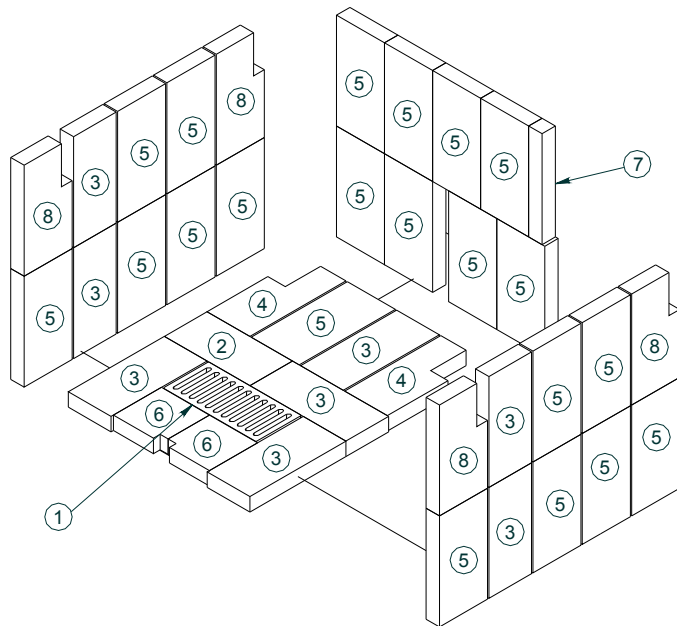
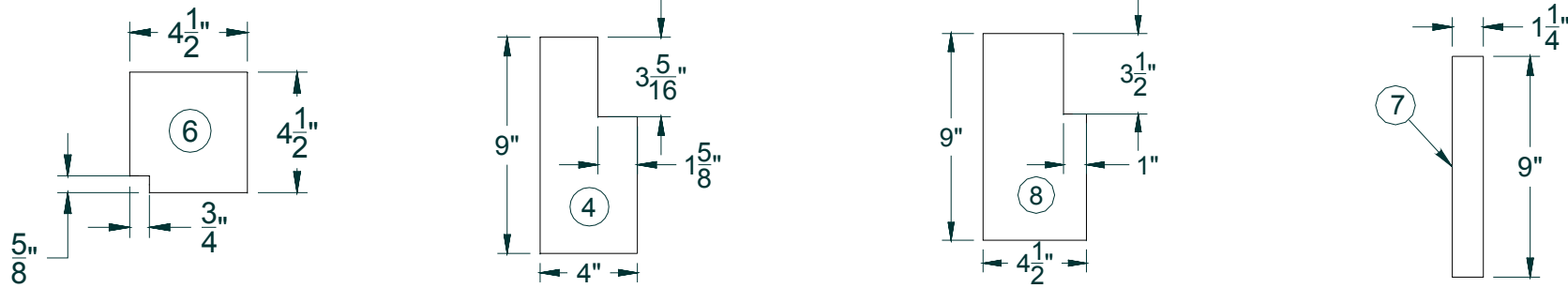

Item	DESCRIPTION	QTY
1	ASHGRATE	1
2	BRICK 4 X 8	1
3	BRICK 4 X 9	8
4	BRICK 4X9 SPECIAL	2
5	BRICK 4.5 X 9	21
6	½ BRICK 4.5X9 SPECIAL	2
7	BRICK 1.25 X 9	1
8	BRICK 4.5X9 SPECIAL	4

## 11. TROUBLE SHOOTING

PROBLEM	CAUSES	SOLUTIONS
Heating inefficient during the first combustions. Lack of draft.	Improper adjustment of the barometric damper (opened too wide). Chimney flue restriction (too long. 90° elbows)	Adjust the damper, minimize the chimney length and use 45° elbows.
Furnace heats well, warm air plenum is very hot by there is not much heat coming out in the room.	Improper installation of the ducts, little static pressure, unbalanced system (too many warm air outlets and not enough cold air inlets).	Reinstall the ducts correctly. Respect the minimum static pressure of 0.20 in. w.c.
Furnace consumes a lot of wood.	The thermostat which controls the damper is continuously activated and is too close to a source of cold. Damper not properly adjusted. House not insulated enough. Ash drawer is not tightly closed. Furnace too small for the surface to be heated. Unbalanced ventilation system, very little heat where the thermostat is located.	Relocate the thermostat. Adjust the chain that links the damper to the servo-motor. Rebalance the ventilation system in order to increase the air flow in the room where the thermostat is located.
Fan start-up is too slow.	Fan "ON" setting too high. Return air is too cold (temperature lower than 65 degrees). Limit control not well located in the warm air plenum.	Lower the temperature starting point. Usually, the limit control is set at 150 degrees, we can under certain conditions, reduce this temperature. Reduce the fresh air flow. Relocate the limit control.
A lot of creosote, moderate heat output.	Wet wood, lack of draft. Barometric damper not properly adjusted. Sooted up chimney.	Use dry wood. Adjust the barometric damper. Clean the chimney flue and the furnace exchangers.
Furnace heats a lot but the warm air plenum does not get hot.	Wet wood or low grade wood. Too much cold air return for the hot air ducts. Unbalanced ventilation system.	Use dry wood. Reinstall the ventilation system correctly.

### IMPORTANT NOTE

FOR, INSTALLATION OF A CENTRAL HEATING VENTILATION SYSTEM, IT IS HIGHLY RECOMMENDED TO CONSULT A HEATING SYSTEM VENTILATION SPECIALIST

**SECTION B: WOOD/OIL COMBINED FURNACES.**

**INSTALLATION  
AND OPERATION INSTRUCTIONS  
FOR UH-CADDY WOOD/OIL  
COMBINED FURNACES**

**READ THIS MANUAL THOROUGHLY  
BEFORE OPERATING THE FURNACE**

CERTIFIED BY OMNI ACCORDING TO CAN/CSA B366.1-M91, UL391 3e ed. 1995,  
rev. 1999 & CAN/CSA B212-93 (JUNE 2000)

**CAUTION**

EXPLOSION OR FIRE HAZARD.  
FOR YOUR SAFETY: DO NOT  
STORE OR USE GASOLINE OR  
ANY FLAMMABLE LIQUIDS OR  
VAPORS IN THE VICINITY OF  
THIS HEATING UNIT.

**CAUTION**

DO NOT ATTEMPT TO LIGHT THE  
BURNER WHEN EXCESS OIL HAS  
ACCUMULATED, WHEN THE  
APPLIANCE IS FULL OF VAPOR OR  
WHEN THE COMBUSTION  
CHAMBER IS VERY HOT.

DO NOT BURN WASTES OR PAPER IN THE APPLIANCE.  
DO NOT LEAVE PAPER OR ANY COMBUSTIBLE MATERIAL  
AROUND THE APPLIANCE.

**PLEASE SAVE THESE DOCUMENTS!**

## GENERAL NOTES

This instruction manual treats mainly of the oil burning unit of your wood/oil combination furnace.

***For any additional information concerning the wood burning furnace, please consult your installation and operation instructions manual for wood and wood/electricity furnaces.***

To obtain the optimal efficiency, follow the advices below regarding the installation and operation of your WOOD/OIL combination furnace.

Respect the local codes (when in doubt, consult your local heating appliances dealer).

Make sure that the clearances indicated on the instruction manual correspond to the specifications in the certification plate.

Make sure that your furnace is installed in conformity with the instructions on the name plate.

All the controls adjustments must be performed by a qualified technician. The controls settings and the fan speed must be in compliance with the recommendations of the Warm Air Heating and Air Conditioning National Association and must respect the static pressure ranges in the warm air plenum of the furnace.

THE INSTALLATION OF THE WOOD/OIL COMBINATION FURNACE MUST BE DONE IN ACCORDANCE WITH THE RULES OF THE AUTHORITIES HAVING JURISDICTION AND THE CAN/CSA B-139 M-91 STANDARD FOR OIL BURNING HEATING APPLIANCES.

The oil burning furnaces are not approved for use with combustible heavier than No.2 oil (furnace oil). **DO NOT USE GASOLINE, TRANSMISSION OIL OR OTHER TYPE OF OIL CONTAINING GASOLINE.**

### 1. DRAFT AND CHIMNEY

The chimney must be conform to the rules of the authorities having jurisdiction and the CAN/CSA B139 M-91 & NFPA 31 standard regarding installation of oil burning heating appliances. The installation of the connecting pipes to the oil unit must be done and approved by a qualified pipe fitter.

The barometric damper provided with the appliance must be properly installed on the flue pipe of the oil unit. The purpose of the damper is to limit the draft, if necessary, in the oil unit evacuation pipe.

Since the evacuation pipe of the oil unit is connected to the evacuation pipe of the wood burning furnace, **the minimum draft to be respected at all times in the evacuation pipe of the wood burning side is - 0.04" W.C.**

### 2. OIL TANK AND PIPING

The maximum capacity of the tank must be 200 gallons and the tank must be located at least 7 feet from the burner. Local codes will govern the size of the air inlets and filling openings as well as the type of plugs to be used. 1 1/4" IPS and 2" IPS are usually accepted as minimum dimensions for the air intake pipes and fill pipes, respectively. The oil line to the burner must be a 3/8" outside diameter copper tubing for runs up to 50 feet and 1/2" o.d. for longer runs. A manual shut-off valve and an oil filter shall follow in sequence on the oil line between the oil tank and the burner. The oil line must be buried or protected adequately to avoid any damage.

## BURNER PUMP

The burner is equipped with a single stage pump. When the pump is connected to a single feeder pipe, a maximum rise of 8 feet is allowed. This height is measured from the tank outlet level to the burner inlet.

When the rise is more than 8 feet and not exceeding 10 feet, a by-pass plug (provided with the burner) must be inserted in the pump and an oil return pipe must be installed. **For more details, see “INSTALLATION INFORMATIONS”, Part No. 21844 on the burner pump.**

If the rise is higher than 10 feet, a two stage pump may be required along with an oil return pipe.

## 3. APPLIANCE INSTALLATION

### LOCATING THE UNIT

The furnace must be installed in a location where combustion air is available in sufficient quantity. In airtight houses, the installation of an outside air intake might be required. (See details in 3- APPLIANCE INSTALLATION, COMBUSTION AIR).

***The owner is responsible for ensuring a proper installation to allow a salubrious operation of the appliance.***

Position the furnace so that the connecting pipe is as short as possible and limit the use of 90° elbows to a minimum.

Provide sufficient clearance to permit easy access for maintenance of the filters, motors, controls and pipe connectors.

### CLEARANCES TO COMBUSTIBLE MATERIALS

<b>MINIMUM INSTALLATION CLEARANCES TO COMBUSTIBLE MATERIALS</b>	
WARM AIR PLENUM AND FIRST 6 FEET OF DUCT	6 in.(152 mm)
PLENUM AFTER THE FIRST 6 FEET = <b>B</b>	1 in. (25.4 mm)
REAR (INCLUDING CLEARANCE FOR MAINTENANCE) = <b>A</b>	24 in. (610 mm)
SIDES (INCLUDING CLEARANCE FOR MAINTENANCE)	24 in.(610 mm)
OIL BURNING UNIT FLUE PIPE	9 in.(229 mm)
WOOD BURNING FURNACE FLUE PIPE	18 in.(458 mm)
* FLOOR	0 in.(0 mm)

**\* ON A COMBUSTIBLE FLOOR, THE USE OF A FLOOR PROTECTION EXCEEDING THE FURNACE BY 8” AT THE REAR AND SIDES AND 18” IN FRONT IS RECOMMENDED.**



**N.B. These appliances must be installed in conformity with the instructions on the name plate.**

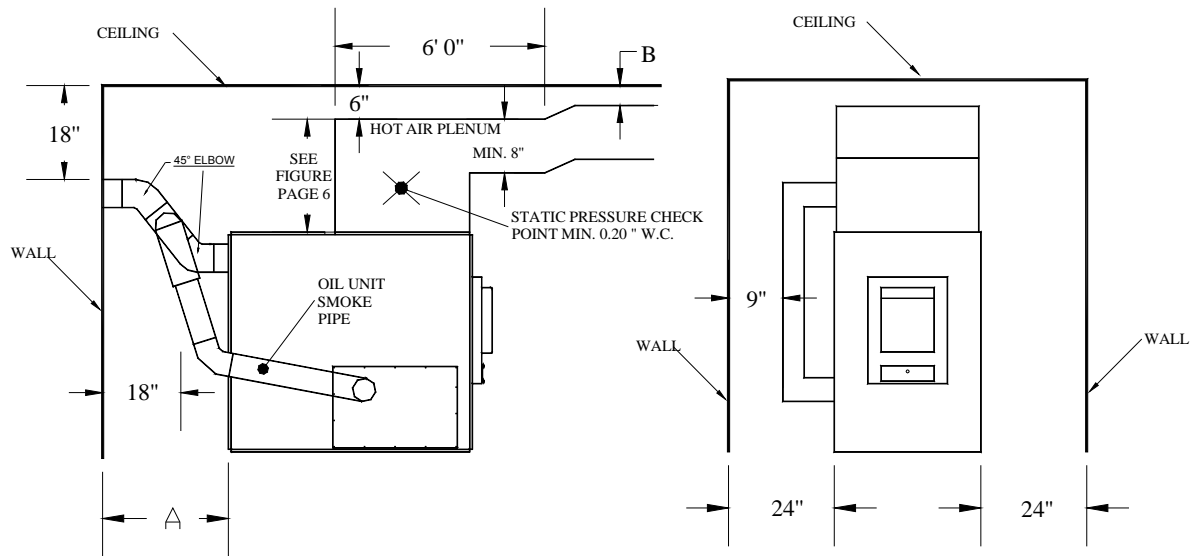

A= 29" ALL MODELS EXEPT CADDY = 24"  
B= 2" ALL MODELS EXEPT CADDY = 1"

**N.B. FOR AIR RETURN, RESPECT THE OPENING SURFACE OF THE OUTSIDE AIR PLENUM OF THE FURNACE. POSITIONING THE APPLIANCE**

## POSITIONING THE APPLIANCE

For a safe and quiet operation, the furnace must be levelled in both directions. Give each "U" shape track, an equal support so that the weight is evenly distributed.

## PIPE CONNECTOR AND DAMPER

The pipe connecting the furnace to the chimney must be as short as possible. The use of 45° elbows is highly recommended for a better evacuation of the smoke in the wood burning furnace. The barometric damper provided with the appliance must be installed in the oil unit evacuation pipe, approximately 24" from the unit flue outlet of the unit.

TYPE OF FURNACE	(UH) OIL BURNING UNIT FLUE PIPE DIAMETER
PSG/ UH-CADDY	5"

## FOR PSG/ UH-CADDY

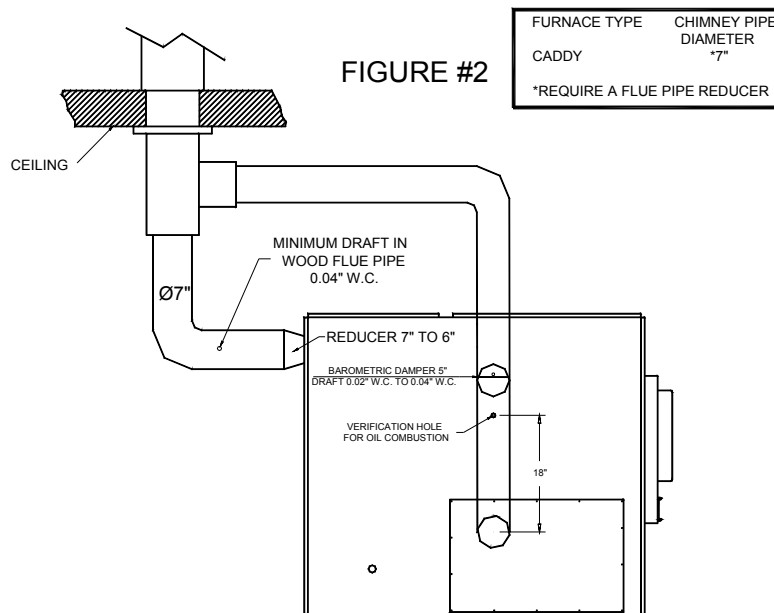
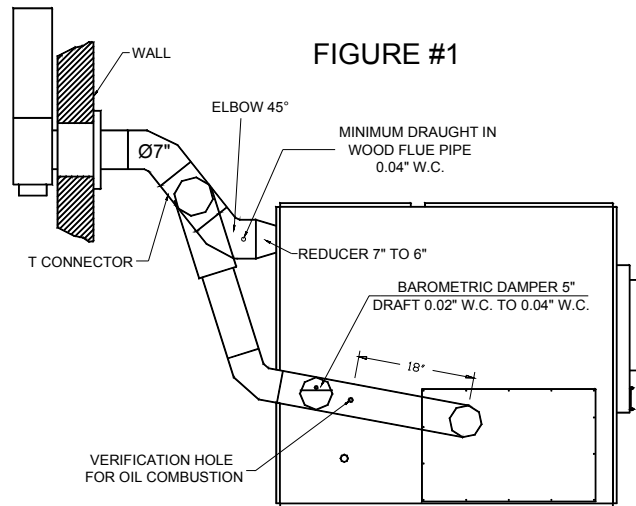

## COMBUSTION AIR

Take note that an airtight house is liable to lack the fresh air needed for proper combustion, specially if you are using appliances that evacuate air from the house, such as:

- Range hood
- Air exchanger
- Clothes dryer
- Bathroom fan
- Central vacuum cleaning system

In that case, it is recommended to install a 4" fresh air inlet in the room or next to the room where the heating appliance is located (see drawing below); choose a wall which is not exposed to dominant winds, depending on the conditions surrounding your house.

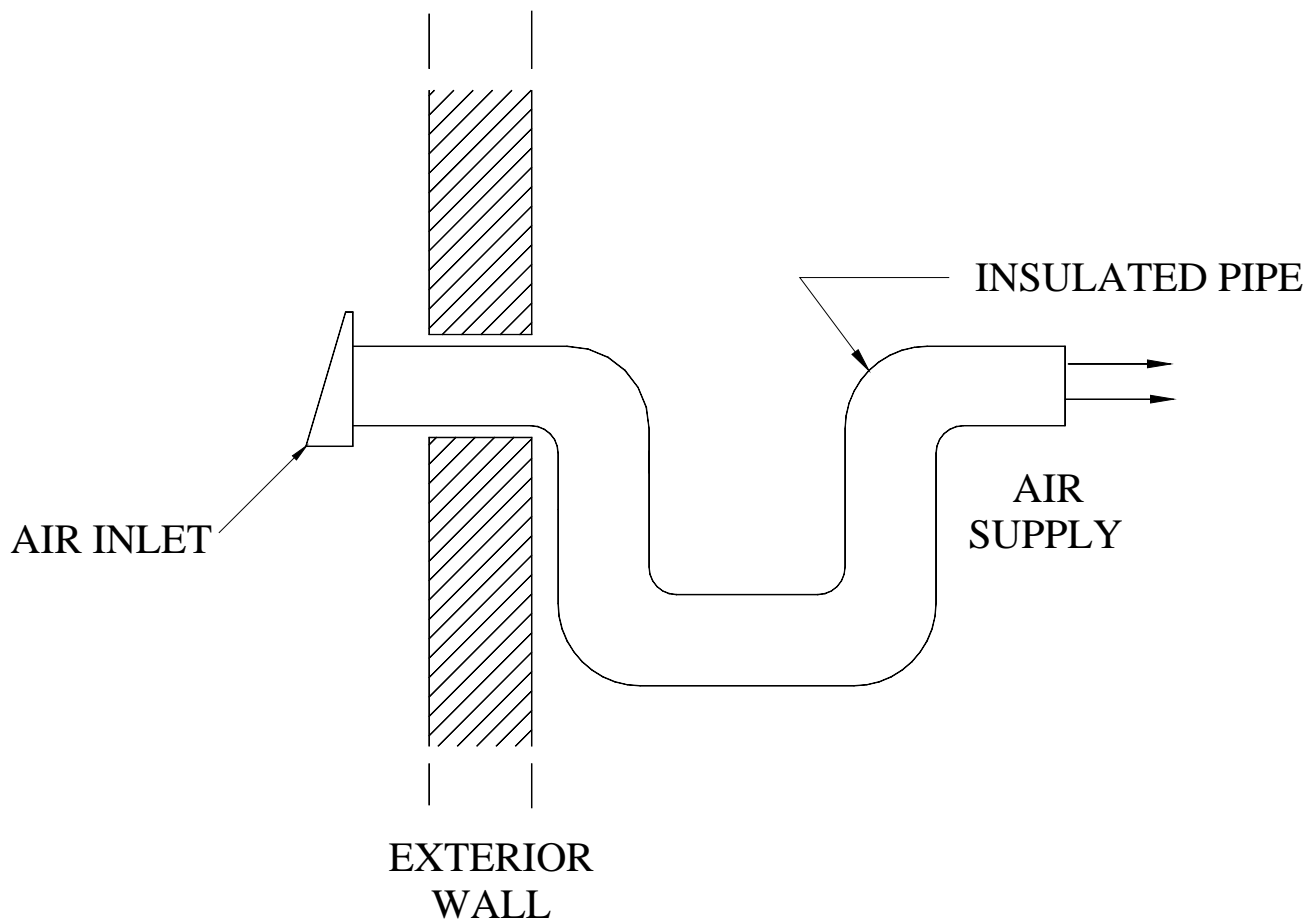

**N.B. The owner is responsible for the salubrity of the premises in case of negative pressure or temporary negative pressure.**

## ELECTRIC COMPONENTS INSTALLATION

All the wires joining the electric components must have the proper length. Run the wires connecting the servo-motor to the relay-transformer away from surfaces that may get hot (see figure #1).

FIGURE #1

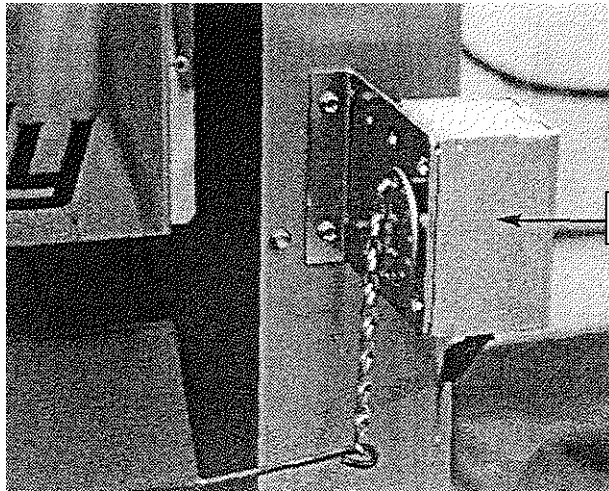

SERVO-MOTOR

## FAN LIMIT INSTALLATION ON PSG UH -CADDY MODELS

The wood fan limit control must be installed with the mounting bracket, in the warm air plenum on the left hand side of the appliance; four holes are pre-drilled on the edge to match the holes on the mounting bracket (see fig. #3). **Use the front holes on the Caddy.**

The fan limit control for the oil unit (affixed to the junction box and relay-transformer, see figure #2) must be installed on the lower left hand side removable panel, near the oil flue outlet; a 1" diameter hole is pre-punched to allow the insertion of the fan limit's sensor).

FIGURE #2

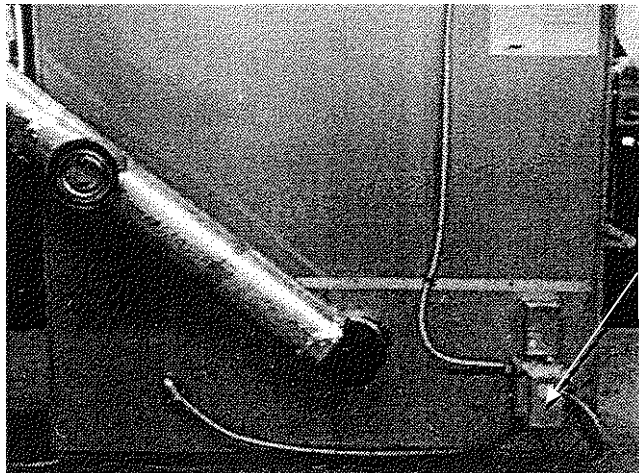

RELAY  
TRANSFORMER

FIGURE #3

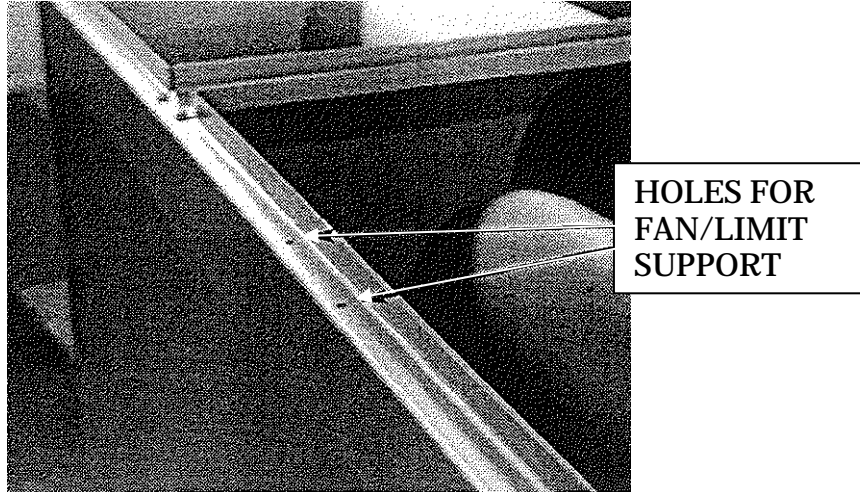

## ELECTRICAL WIRING

The whole wiring from the distribution panel to the heating unit shall comply with the applicable electrical standards and local codes. The unit should be connected to its own 15 amp/120VAC electric circuit (see electrical diagram on page 18).

## THERMOSTAT

Both the wood and oil thermostats must be installed side by side on an interior wall, in a location where they are not affected by the air draft coming from the furnace's blower; they must be level and at least 55 inches above the floor.

## FAN CONTROL

The oil fan limit control settings may vary depending on the type of building and heating installation. The "fan off" temperature is factory set at 100°F and the "fan on" setting should be positioned as close as physically possible to the "fan" off" setting; the high limit is set at 250° and these settings should allow proper operation in most installations.

In order for the blower to run for long enough periods, the "fan off" setting must not be set too high but too low a setting will result in undesirable cold air circulation. To modify this setting, turn the indicator to the desired position on the temperature scale of the fan limit control.

All adjustments of the controls must be performed by a qualified technician. The controls settings and the blower speeds must be set in accordance with the recommendations of the Warm Air Heating and Air Conditioning National Association.

To obtain a continuous air circulation during summer months, simply use the red manual switch located on the cover of the junction box which controls the low speed in either "on" or "off" position.

It is not recommended to let the blower run on continuous mode when heating with wood as the wood furnace must reach a certain temperature before the blower starts to perform adequately.

## **COMBUSTION SAFETY CONTROL**

The AFG type oil burner is equipped with an electronic control (# R7184B1032) including a pre-purge function and a new more durable drive motor.

### **PRE-PURGE**

When there is a call for heat, the burner's fan will run for 15 seconds before the actual ignition takes place to vent the combustion chamber and generate a proper draft. This will result in a smoother ignition of the oil burner.

### **SAFE OPERATION**

If the flame goes out while the burner is running, the CAD cell will detect it; the control will then switch to the "RECYCLE" mode and cut the fuel supply to the burner for 60 seconds. After this delay, the control goes back to "IGNITION" mode. If the flame goes out 3 times in a row, the control will switch to the "LOCKOUT" mode to prevent a continuous cycling of the ignition process, which would cause a premature sooting of the combustion chamber and smoke pipe. To deactivate the "LOCKOUT" mode, press and hold the reset button of the control for 30 seconds.

A green diagnostic LED on the control has four states:

- On = Flame present
- Off = No flame
- 2 seconds On, 2 seconds Off = "Recycle" mode
- 1/2 second On, 1/2 second Off = "Lockout" mode TEMPORARY SHUT-OFF

By pressing and holding the reset button, the burner will shut-off until the reset button is released. When the button is released, the control will start over at the beginning of the normal cycle.

***FOR ADDITIONAL INFORMATIONS ON OPERATION SEQUENCES OF THE BURNER, CONSULT THE BURNER INSTRUCTION MANUAL.***

## **COMBUSTION ADJUSTMENT AND VERIFICATION**

To enjoy the efficiency of our oil burning units, you must respect the following criterias:

### **TOOLS REQUIRED:**

- DRAFT GAUGE
- SMOKE TESTER
- PUMP PRESSURE GAUGE
- NOZZLE AND ELECTRODES POSITION TESTER
- COMBUSTION TESTER

### **CHECK LIST:**

- SELECTION OF NOZZLE AND HEAD
- NOZZLE / ELECTRODES POSITION IN RELATION TO THE HEAD
- PUMP PRESSURE
- OIL LINE IS BLEED
- LOW FIRING RATE BAFFLE (INSIDE THE BURNER) REQUIRED ON UH-CADDY.
- FAN SPEED
- BAROMETRIC DAMPER POSITION

## COMBUSTION VERIFICATION PROCEDURE:

- A- DRILL A 9/32" DIAMETER HOLE IN THE EVACUATION PIPE APPROXIMATELY 18" FROM THE OUTLET.
  - B- CLOSE THE DOOR AND THE AIR INTAKE(S) OF THE WOOD BURNING FURNACE.
  - C- LIGHT THE BURNER FOR AT LEAST 10 TO 15 MINUTES.
  - D- OVER THE FIRE DRAUGHT = -0.01 TO -0.02 W.C. (THE DRAFT OVER THE FIRE MUST BE MEASURED IN THE OPENING IN THE PULSATION TRAP).
  - E- SMOKE TEST BETWEEN 0 AND 1 ON THE SHELL BACHARACH SCALE (TRACES).
  - F- DRAFT IN THE CHIMNEY =-0.02 TO -0.04 W.C.
  - G- PERCENTAGE OF EXCESS AIR = 20 TO 40%, 12% CO<sub>2</sub>, 4.6% O<sub>2</sub>.
  - H- AVERAGE EFFICIENCY OF 80 TO 85 %.
  - I- TIGHTEN ALL THE LOCKING SCREWS AFTER COMPLETING THE FINAL ADJUSTMENT.
- N.B. – The barometric damper provided with the appliance must be properly installed on the flue pipe of the oil burning unit. The purpose of the damper is to adjust the draft in the evacuation pipe of the oil burning unit to the recommended level. Since the evacuation pipe of the oil burning unit is connected on the evacuation pipe of the wood burning furnace, the minimum draft to be respected is 0.04" W.C. in the evacuation pipe of the wood burning side, at all time. ***In fact, a barometric damper that would be opened too wide could cause an important loss of draft in the evacuation pipe of the wood burning furnace.***

## ELECTRODES SETTING

The electrodes must be adjusted by a qualified technician. A proper positioning of the electrodes is important to get an efficient lighting of the oil.

### ELECTRODE SETTING FOR "F" HEAD

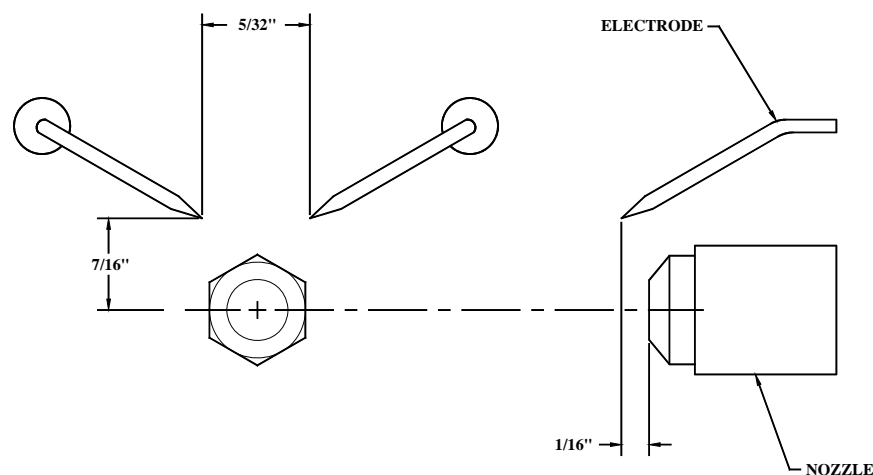

**WARNING:**

1. REFER TO THE RATING PLATE FOR THE PUMP PRESSURE AND THE NOZZLE TYPE.
2. REFER TO THE BECKETT INSTRUCTION MANUAL FOR DETAILS ON THE BECKETT PUMP.
3. FOR ELECTRODES SETTING SEE THE BECKETT MANUAL.
4. FOR THE START-UP AND ADJUSTMENT OF THE BURNER SEE THE INSTRUCTION MANUAL OF THE BURNER.
5. IN CASE OF BURNER FAILURE, REFER TO THE BURNER MANUAL.

## **4- APPLIANCE START-UP**

The start-up must be performed by a qualified technician. Make sure the installation is completed and the oil tank has been filled up. The oil line must also have been purged.

**CAUTION: CLOSE THE BLOWER COMPARTMENT ACCESS PANEL BEFORE STARTING THE BURNER.**

## **5- PROLONGED CLOSING**

- A) Cut off the electric circuit
- B) Close the oil shut-off valve

NOTE: The shut-off valve must be closed when the appliance is out of service for a prolonged period of time.

## **6- MAINTENANCE**

At the beginning of heating season, have the complete installation inspected by a qualified service man, especially the lighting system and the controls.

**NOTE: THE UNIT'S MAINTENANCE, REPAIRS AND THE CLEANING OF THE OIL FILTER MUST BE DONE BY A QUALIFIED TECHNICIAN.**

## **SERVICE**

Before calling for service, first check the following:

- Fuel supply
- Electric fuses or breakers
- Thermostat setting
- Fan limit controls settings
- The state of the green diagnostic LED on the burner control (see section: APPLIANCE INSTALLATION, J- COMBUSTION SAFETY CONTROL).

## MAINTENANCE

**WARNING:** *Turn off electric power supply before servicing the unit.*

1. The furnace, the burner and the flue pipe should be cleaned at least once a year.
2. The nozzle should be inspected and replaced if needed.  
Handle with care to avoid damaging its surface.
3. The electrodes should be adjusted as indicated in the burner manual.
4. Lubricate the burner motor bearings twice a year.  
(2 or 3 drops of SAE 20 non detergent lubricating oil).
5. The oil filter should be replaced annually

Burner no.: \_\_\_\_\_ Model: \_\_\_\_\_ Date of installation: \_\_\_\_\_

Service Telephone no.: Day: \_\_\_\_\_ Night: \_\_\_\_\_

Dealer's name and address: \_\_\_\_\_

### TEST REPORT :

CO<sub>2</sub> \_\_\_\_\_% Temp. at stack: \_\_\_\_\_ Draft at stack: \_\_\_\_\_ w.c.

Nozzle output: \_\_\_\_\_ GPH Smoke colour: \_\_\_\_\_

Inspected by : \_\_\_\_\_

## FILTERS

**The furnace should never be operated without filters.**

This applies especially to temporary heating during construction period. Operating the furnace without filters would allow dust and other particles in the air to circulate freely and to penetrate into the fan and motor carters causing some defects. Clean and replace filters as often as required.

**Note : The operation cost is higher when using a dirty filter.**

# 7- ELECTRICAL DIAGRAMS

## WIRING DIAGRAM FOR PSG/UH CADDY

(The location of the wood limit is on the plenum and the location of the oil limit is on the panel towards exhaust pipe)

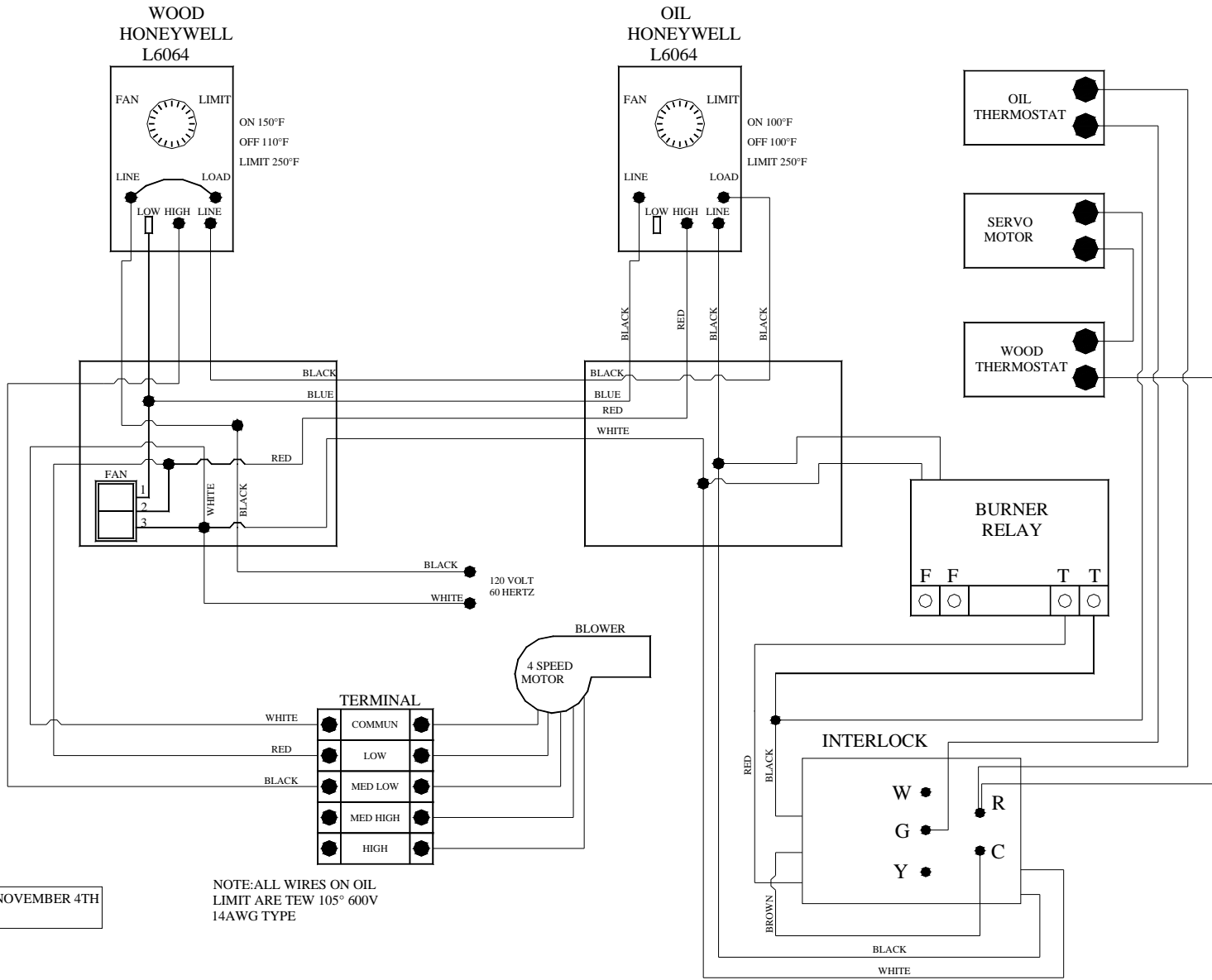

REVISION NOVEMBER 4TH  
2008

NOTE: ALL WIRES ON OIL  
LIMIT ARE TEW 105° 600V  
14AWG TYPE

## 8- TECHNICAL DATA

### UH – CADDY

MODEL	BURNER TYPE	BTU INPUT	NOZZLE	HEAD	STATIC PLATE	PRESSURE AT THE PUMP	H.P. MOTOR FAN
UH-CADDY	BECKETT AFG	91,000	0.65, 70° W (DELAVAN)	F3	2 3/4	120 PSI	1/3 H.P.
UH-CADDY	RIELLO/F3	91,000	0.65, 70° W (DELAVAN)	---	---	120 PSI	1/3 H.P.
UH-CADDY	AERO/FAF C-2X	91,000	0.65, 70° W (DELAVAN)	---	---	120 PSI	1/3 H.P.

*For any additional informations, consult the rating plate on the left hand side of the appliance.*

## PSG LIMITED LIFETIME WARRANTY

The warranty of the manufacturer extends only to the original consumer purchaser and is not transferable. This warranty covers brand new products only, which have not been altered, modified nor repaired since shipment from factory. Proof of purchase (dated bill of sale), model name and serial number must be supplied when making any warranty claim to your PSG dealer.

**This warranty applies to normal residential use only. Damages caused by misuse, abuse, improper installation, lack of maintenance, over firing, negligence, accident during transportation, power failures, downdrafts, or venting problems are not covered by this warranty.**

This warranty does not cover any scratch, corrosion, warping, or discoloration caused by over firing, abrasives or chemical cleaners. Any defect or damage caused by the use of unauthorized parts or others than original parts void this warranty. An authorized qualified technician must perform the installation in accordance with the instructions supplied with this product and all local and national building codes. Any service call related to an improper installation is not covered by this warranty.

The manufacturer may require that defective products be returned or that digital pictures be provided to support the claim. Returned products are to be shipped prepaid to the manufacturer for investigation. If a product is found to be defective, the manufacturer will repair or replace such defect. Transportation fees to ship the product back to the purchaser will be paid by the manufacturer. Repair work covered by the warranty, executed at the purchaser's domicile by an authorized qualified technician requires the prior approval of the manufacturer. Labour cost and repair work to the account of the manufacturer are based on predetermined rate schedule and must not exceed the wholesale price of the replacement part. All parts and labour costs covered by this warranty are limited according to the table below.

The manufacturer at its discretion may decide to repair or replace any part or unit after inspection and investigation of the defect. The manufacturer may, at its discretion, fully discharge all obligations with respect to this warranty by refunding the wholesale price of any warranted but defective parts. The manufacturer shall in no event be responsible for any special, indirect, consequential damages of any nature, which are in excess of the original purchase price of the product. A one-time replacement limit applies to all parts benefiting from a lifetime coverage.

DESCRIPTION	WARRANTY APPLICATION	
	PARTS	LABOUR
Castings, combustion chamber (welds only), castings, and heat exchanger (welds only).	Lifetime	3 years
Stainless steel firebox components, secondary air tubes*, surrounds and heat shields, ash drawer, and plating* (defective manufacture).	5 years	3 years
Carbon steel firebox components, glass retainers, handle assembly, C-Cast baffle*, and vermiculite baffle*.	3 years	1 year
Oil burner, electrical elements, blowers, heat sensors, switches, rheostat, relays, damper motor, fan limit control, PC board, wiring, and other controls.	2 years	1 year
Ceramic glass (thermal breakage only*), paint (peeling), gaskets, insulation, and ceramic fibre blankets.	1 year	n/a
Firebrick	n/a	n/a

*\*Pictures required*

Shall your unit or a components be defective, contact immediately your **PSG** dealer. Prior to your call make sure you have the following information necessary to your warranty claim treatment:

- Your name, address and telephone number;
- Bill of sale and dealer's name;
- Serial number and model name as indicated on the nameplate fixed to the back of your unit;
- Nature of the defect and any relevant information.

**Before shipping your unit or defective component to our plant, you must obtain from your PSG dealer an Authorization Number. Any merchandise shipped to our plant without authorization will be refused automatically and returned to sender.**