

**INSTALLATION INSTRUCTIONS FOR THE
BLOWER ASSEMBLY, COLD AIR RETURN
BOX, AND LIMITING BOARD**

PA08565

MAX CADDY FURNACE



Summary

1. INSTALLATION	4
1.1 Cold air return box installation.....	4
1.2 Cold Air Return Box Installation	7
1.3 Limiting board installation	10
1.4 RTD support bracket installation (resistance temperature detector).....	12
1.5 Servomotor installation	14

Blower assembly, cold air return box, and limiting board

Content of the box :

CONTENTS OF THE BOX
1 X BLOWER ASSEMBLY MANUAL KIT FOR MAX CADDY
27 X #10 X 1/2" "A" TYPE METAL SCREW
2 X 1/4-20 X 1" ELEVATOR BOLT
1 X 100 OHM RTD - 38" WIRE
1 X RTD SUPPORT
1 X #8 X 1/2" METAL SCREW
1 X 3/8" 1 SCREW CONNECTOR FOR BX WIRE
1 X RED PLASTIC SLEEVE FOR BX WIRE
2 X RED PLASTIC SLEEVE FOR BX WIRE (ANTI-SHORT SIZE-2)
1 X 3/4" SCREW CONNECTOR FOR BX WIRE

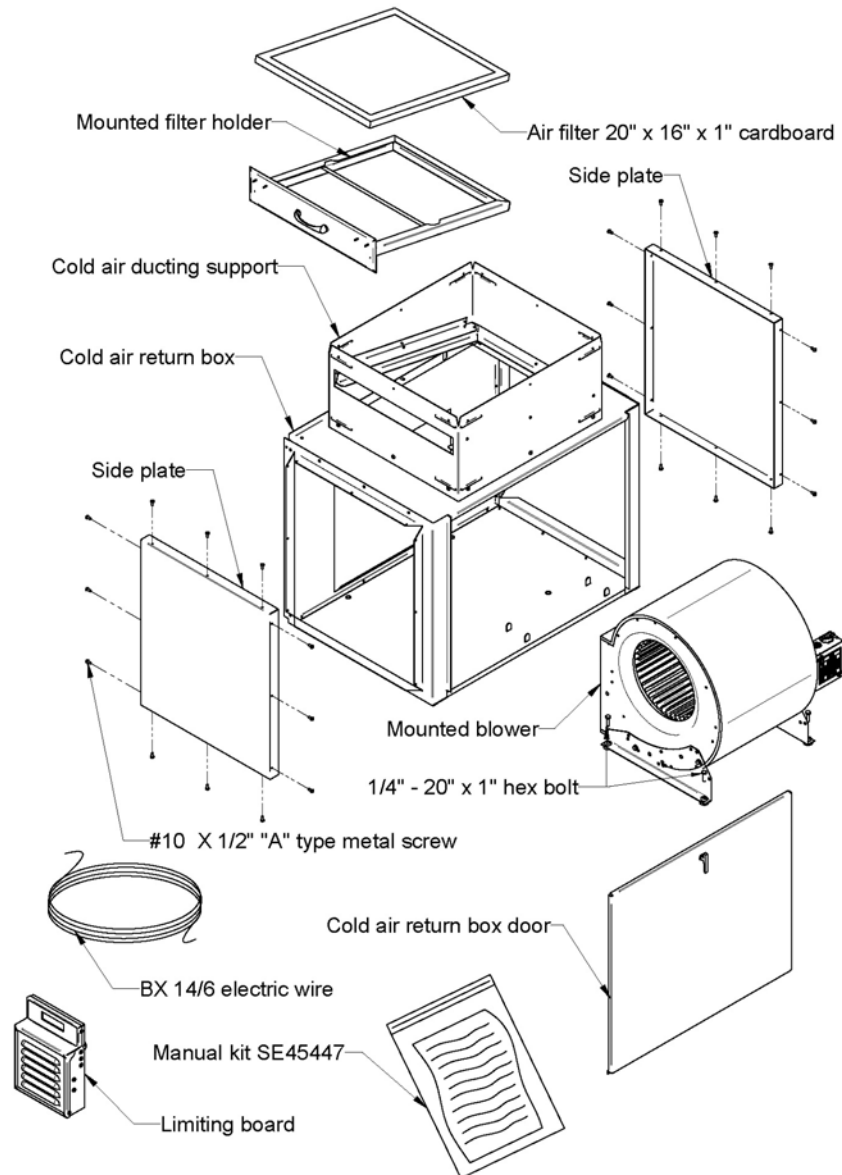

1. INSTALLATION

1.1 Cold air return box installation

Before installing the cold air return box, you need to remove the back panel gasket and the back panel as shown below. To do so, remove the 8 screws.

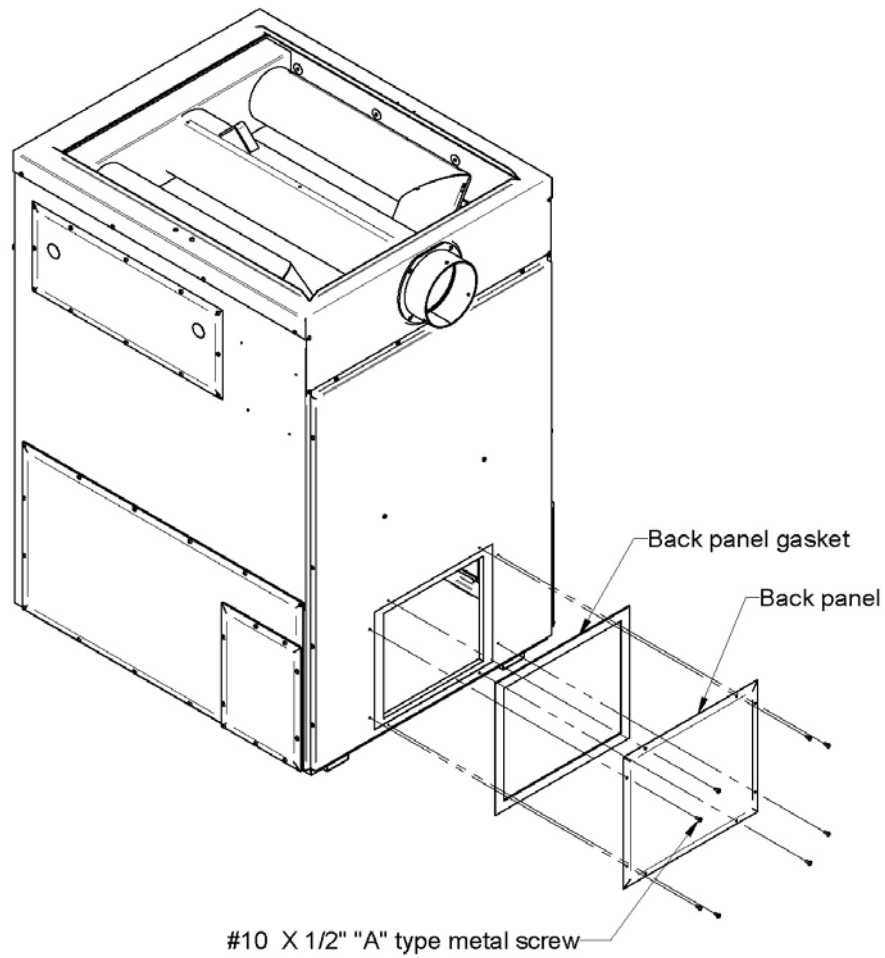

Remove the cold air ducting support from the cold air return box. To do so, remove the 12 screws as shown below. Keep these screws. You will need them to install the cold air ducting support in the new location.

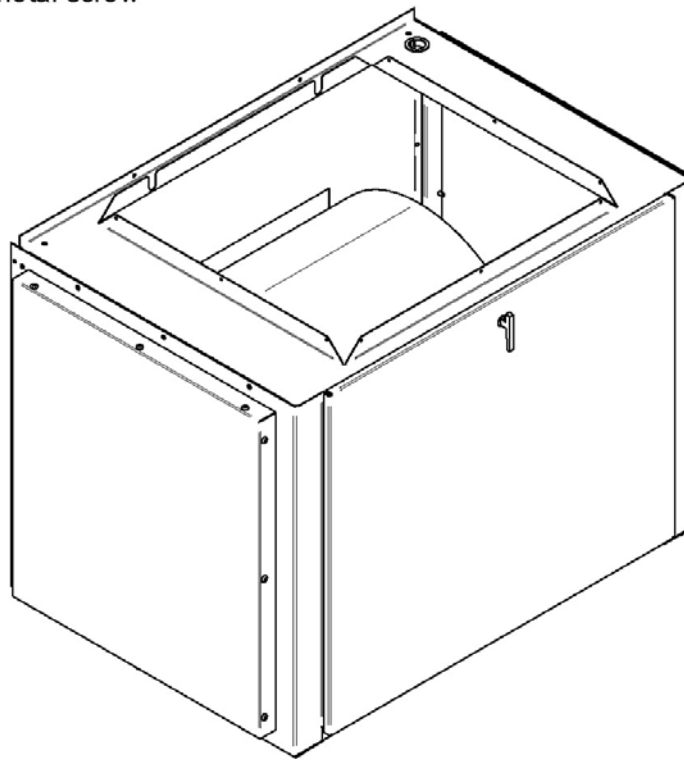
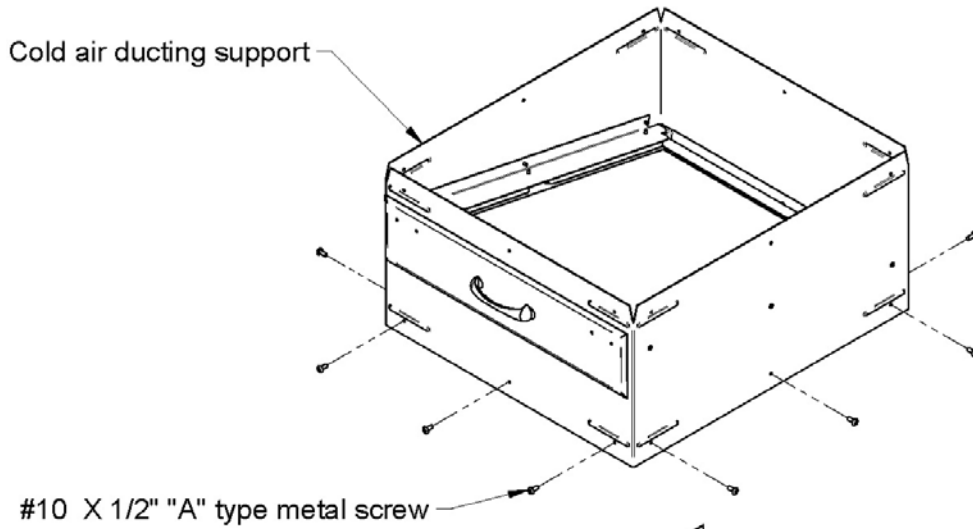

Then, secure the cold air return box to the furnace. To do so, use the 8 screws as shown below. Then, level the cold air return box by screwing or unscrewing the elevator bolts.

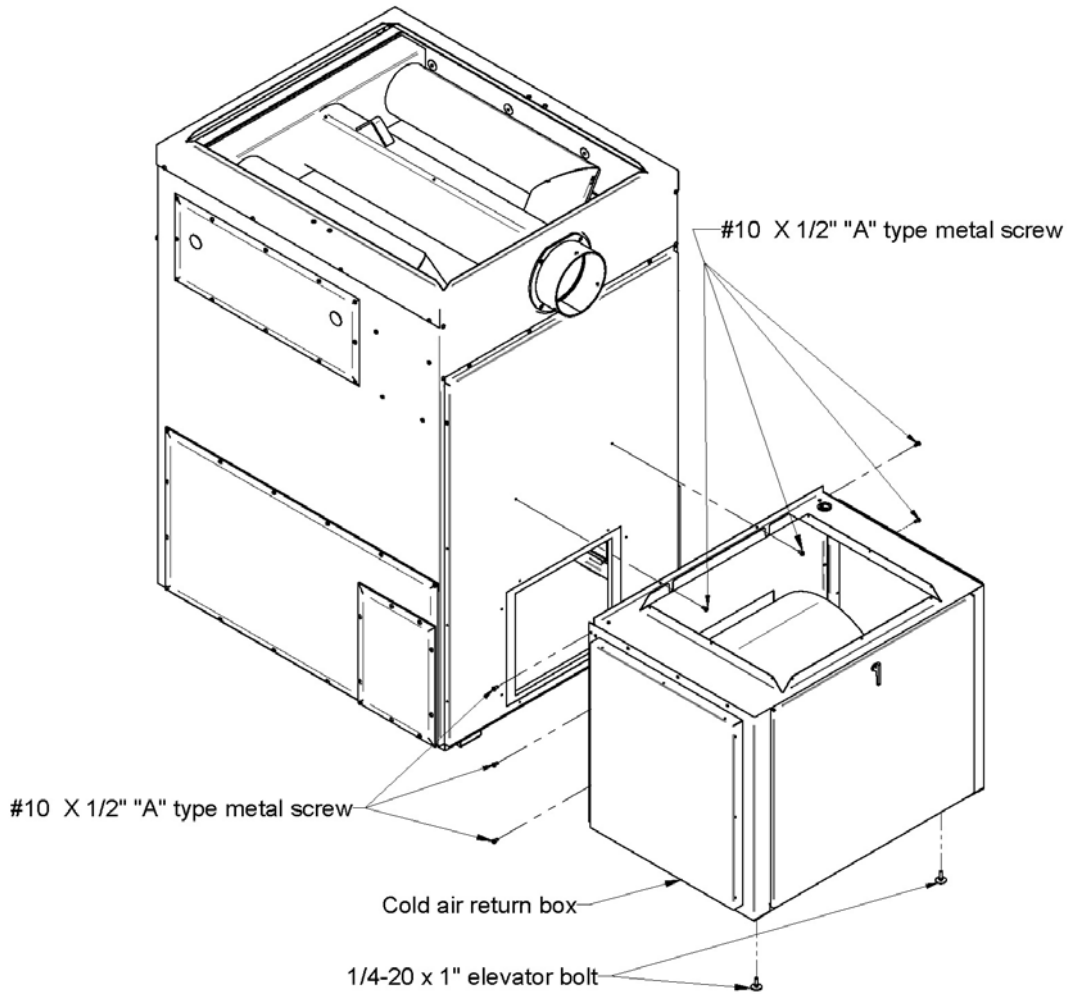

1.2 Cold air ducting support installation

On the cold air return box, you will find two side plates and the cold air return box door. The cold air ducting support can be configured in several ways. You have the flexibility to choose the desired configuration depending of your installation. Indeed, some installations have obstacles making the installation of the cold air ducting support difficult. Configurations differ depending on the chosen location of the cold air ducting support. You will find the different configurations in the following pages.

In order to realize the various configurations, you must remove the three screws retaining the side plate where you wish to install the cold air ducting support. Keep the screws which retained the side plate to install the side plate at the new desired location. The side plate and the cold air ducting support must be secured using nine screws each (kept from the previous step). Remaining screws are provided with the cold air return box.

Installation of the cold air ducting support at the **RIGHT** of the cold air return box

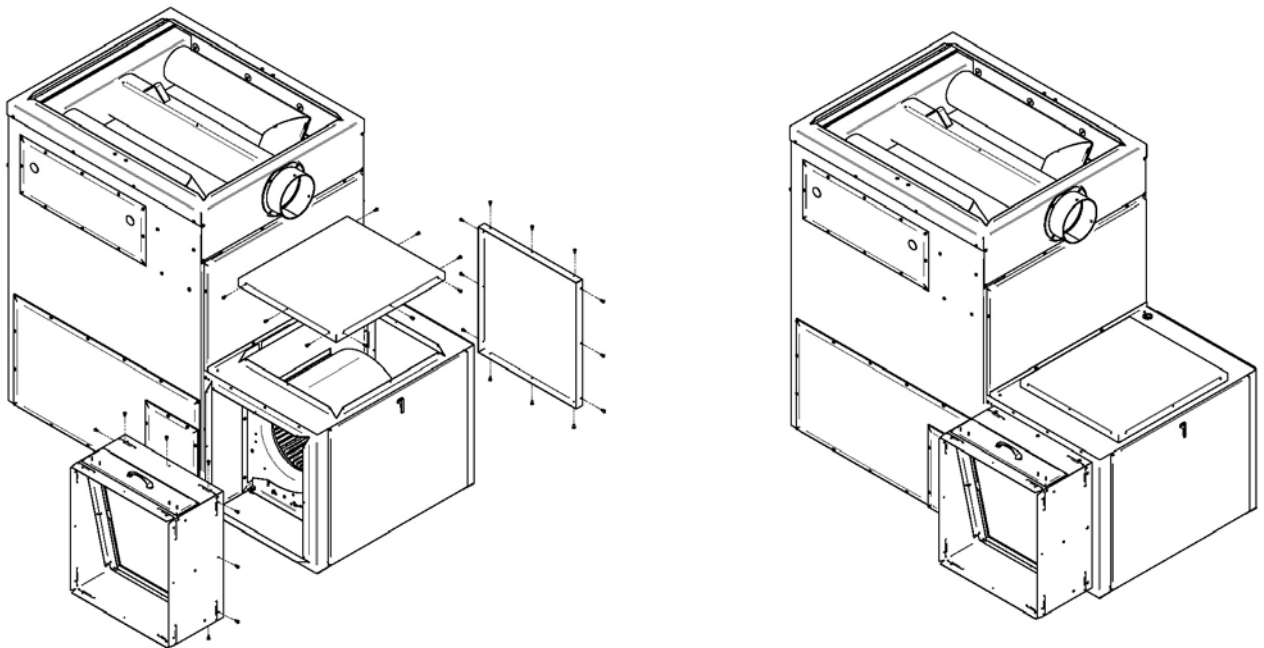

Installation of the cold air ducting support at the **LEFT** of the cold air return box

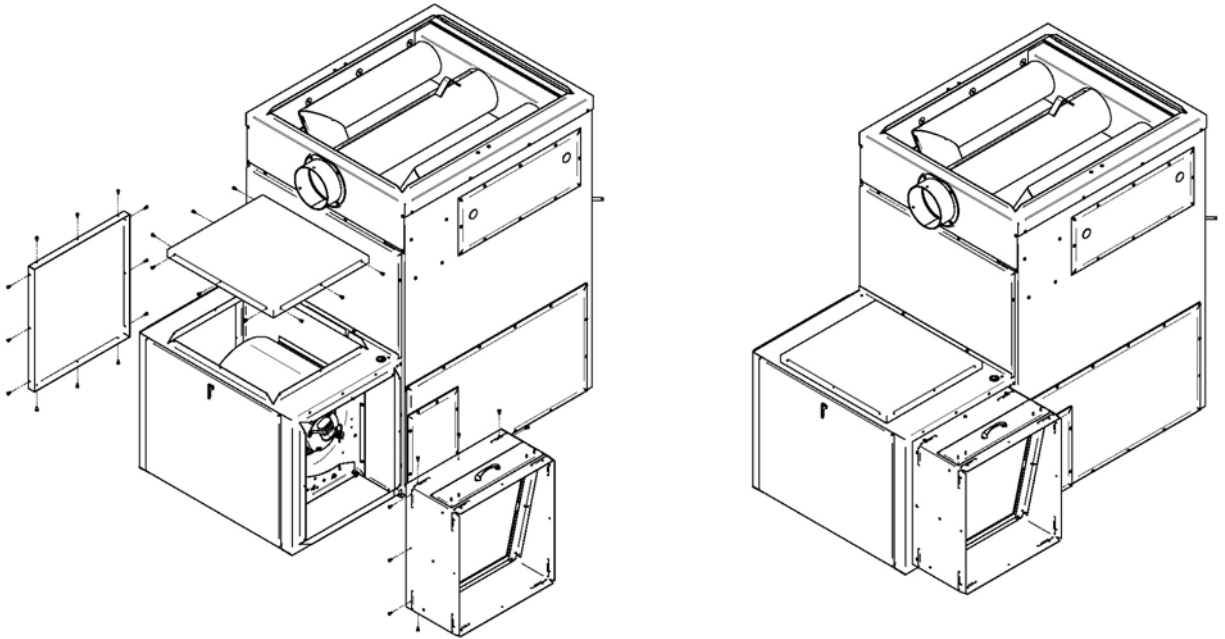

Installation of the cold air ducting support **ON TOP** of the cold air return box with filter exit towards the **RIGHT**

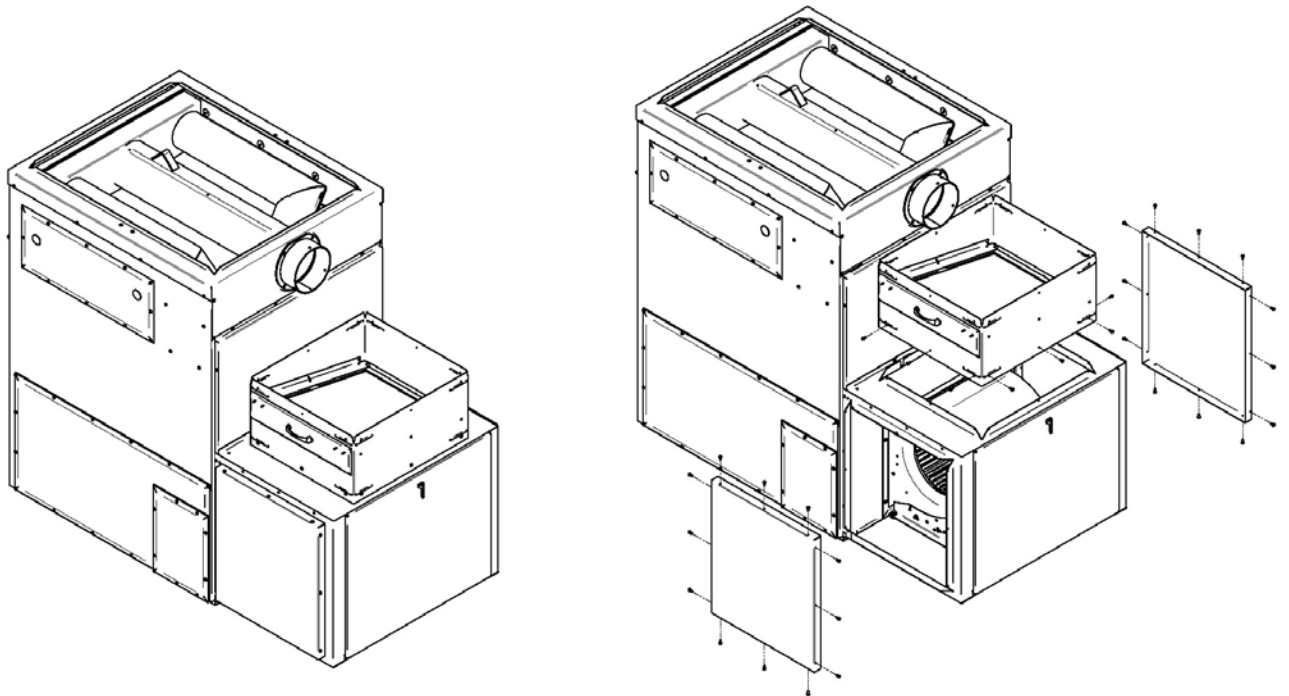

Installation of the cold air ducting support **ON TOP** of the cold air return box with filter exit towards the **LEFT**

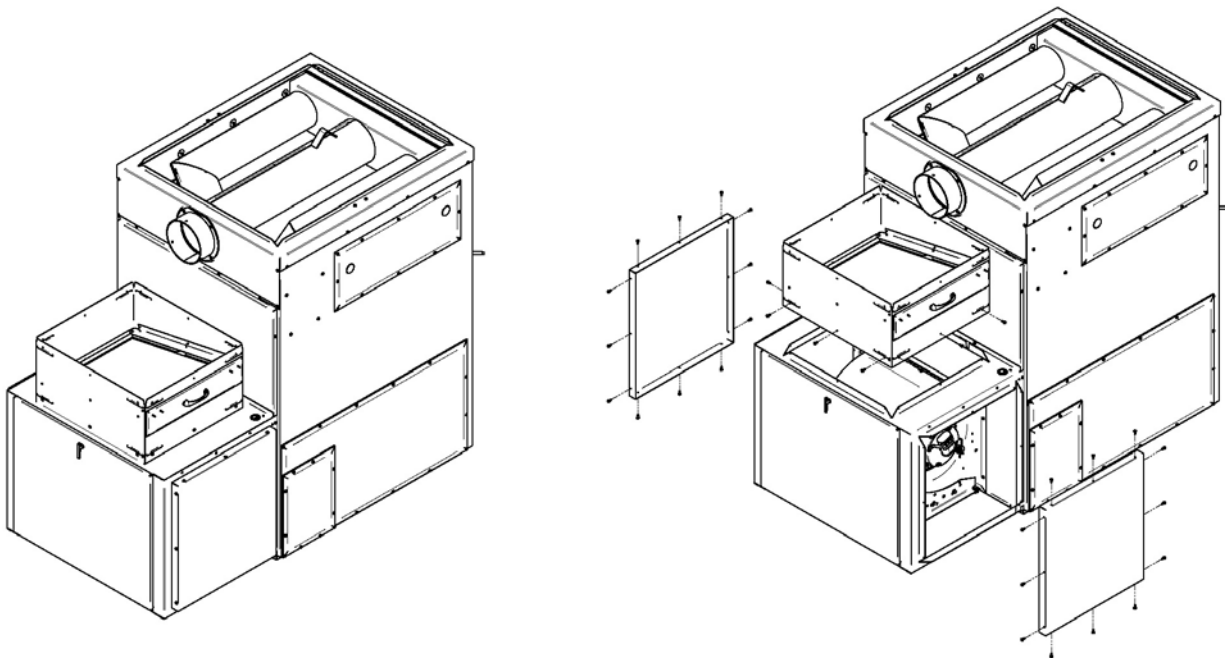

1.3 Limiting board installation and connection

The limiting board may be installed on either side of the furnace. Remove the 4 screws secured on the side of the furnace where you wish to install the limiting board, either on the left or on the right side, and keep these screws. Remove the access panel of the limiting board. Secure the limiting board where you removed the screws from the furnace. Refer to the electric wiring diagram in the owner's manual of the furnace for the electrical connections. Do not screw the access panel back on the limiting board until all connections are made.

Limiting board installed on the **RIGHT** side of the furnace

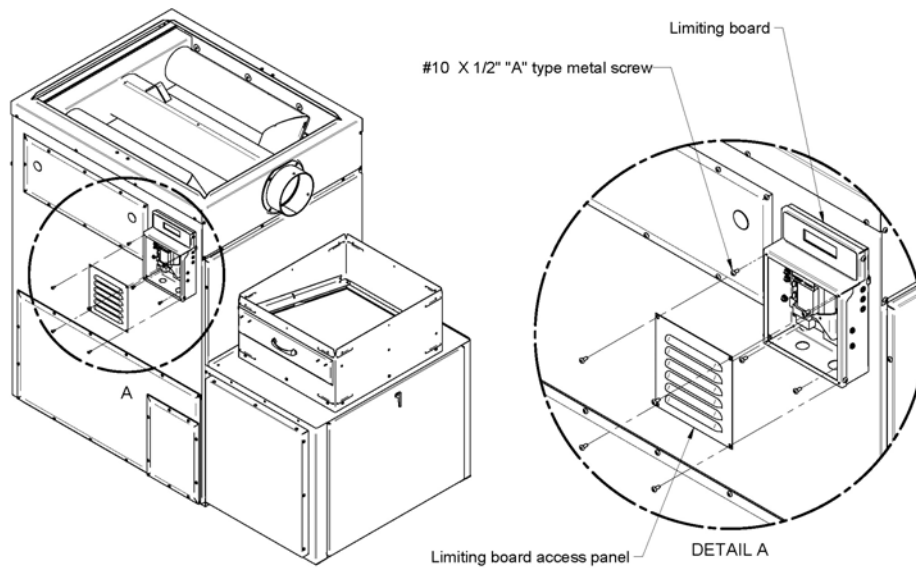

Limiting board installed on the left side of the furnace

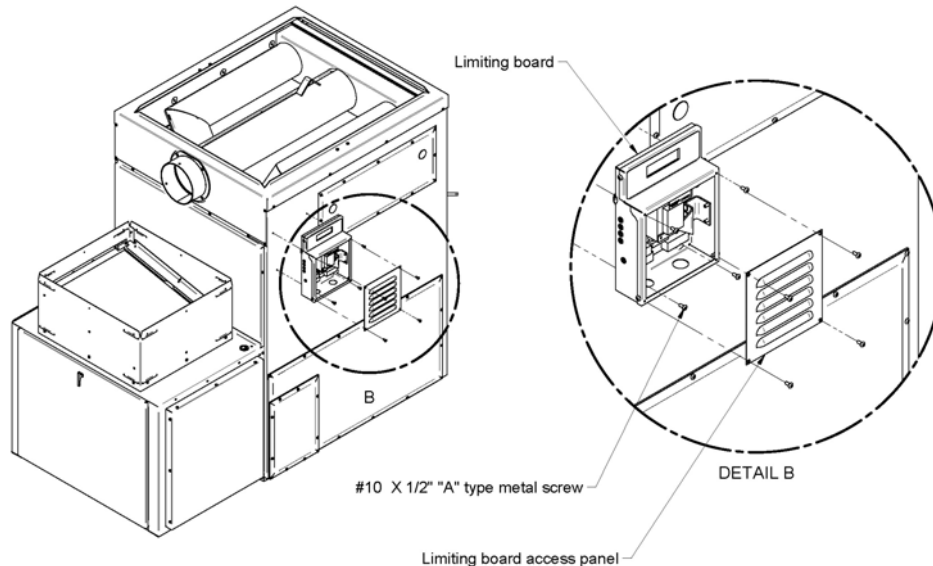

Now, it is time to make the connection between the limiting board and the blower. Since the limiting board may be installed on either side of the furnace, refer to the drawings below to run the wire properly.

Limiting board installed on the **RIGHT** side of the furnace

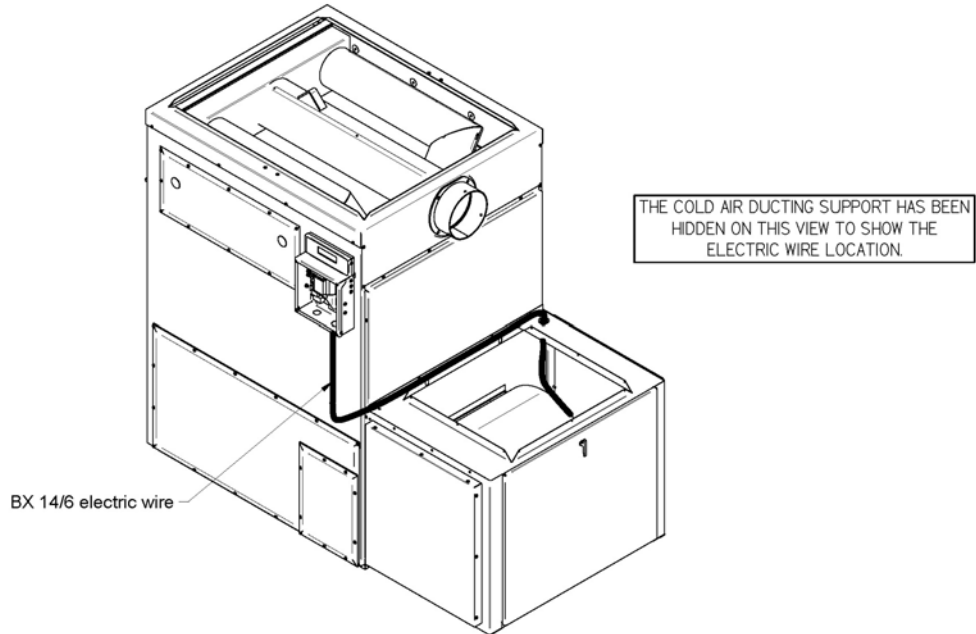

Limiting board installed on the **LEFT** side of the furnace

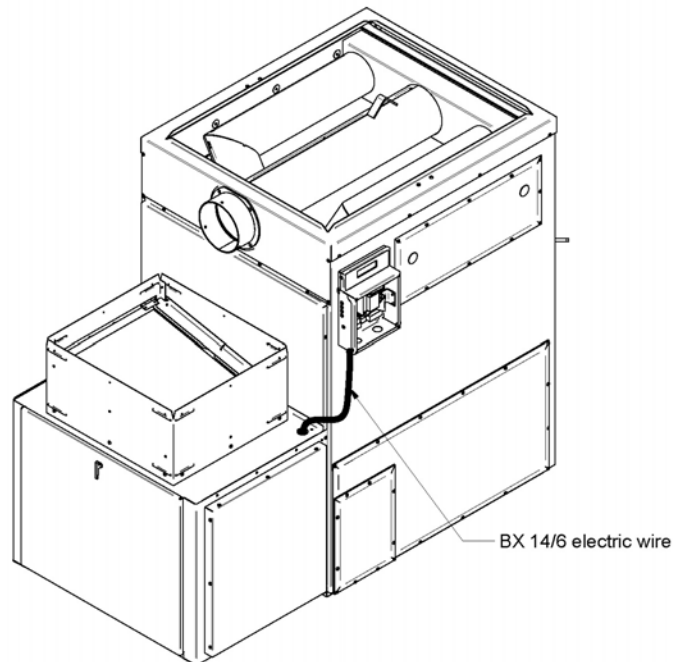

1.4 RTD support bracket installation (resistance temperature detector)

Your Max Caddy furnace is equipped with a RTD probe (resistance temperature detector). This RTD probe must be installed on the RTD support bracket. The RTD support bracket may be installed on left side or on the right side of the furnace. To install it, all you need to do is to screw it in place in the two pre-drilled holes as shown below. To install the RTD, follow the instructions in the manual of the furnace.

RTD support bracket installed on the **RIGHT** side of the furnace

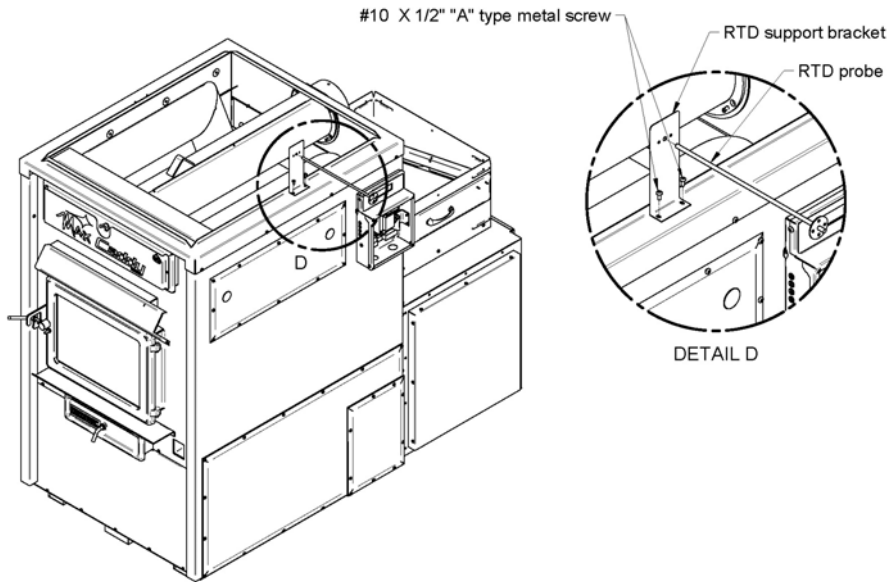

RTD support bracket installed on the **LEFT** side of the furnace

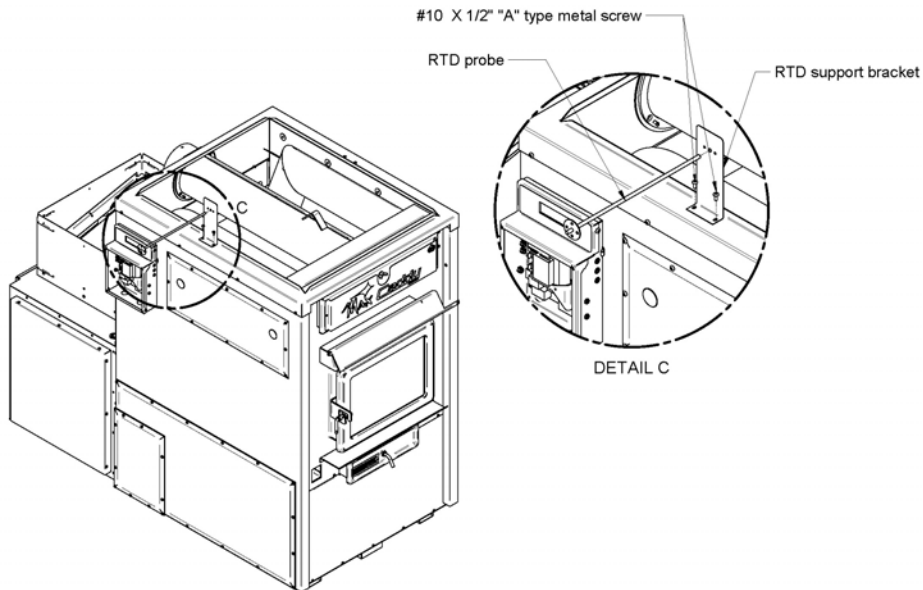

Once the RTD probe is installed on the RTD support bracket, you need to connect the RTD probe to the limiting board. To run the wire properly, refer to the drawings below. Refer to the electric wiring diagram in the owner's manual of the furnace for the electrical connections.

RTD probe installed on the **RIGHT** side of the furnace

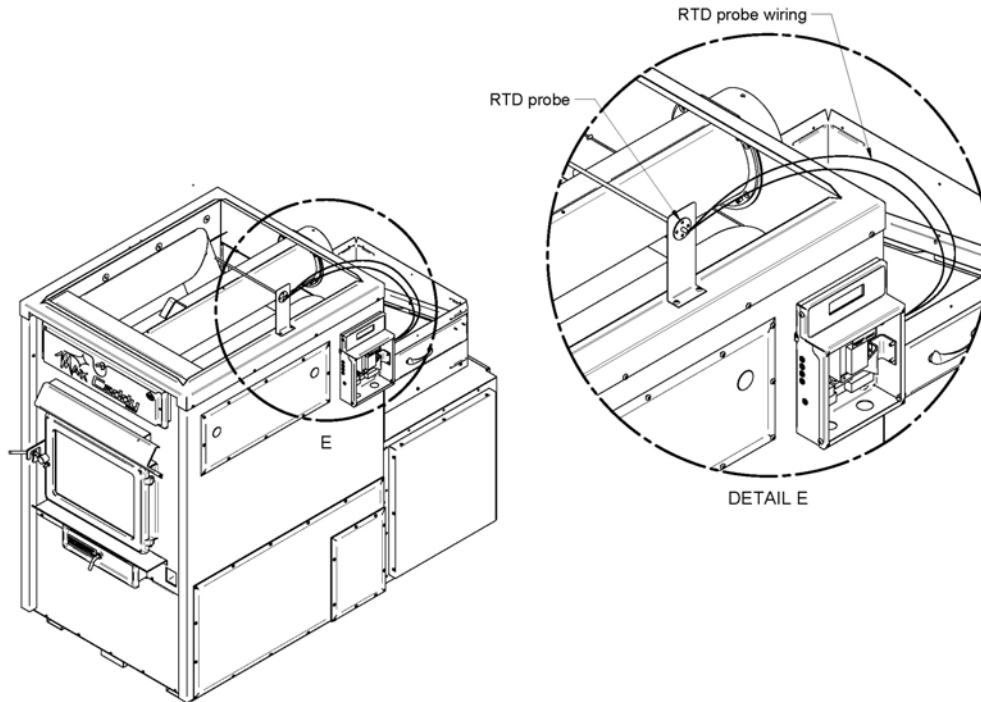

RTD probe installed on the **LEFT** side of the furnace

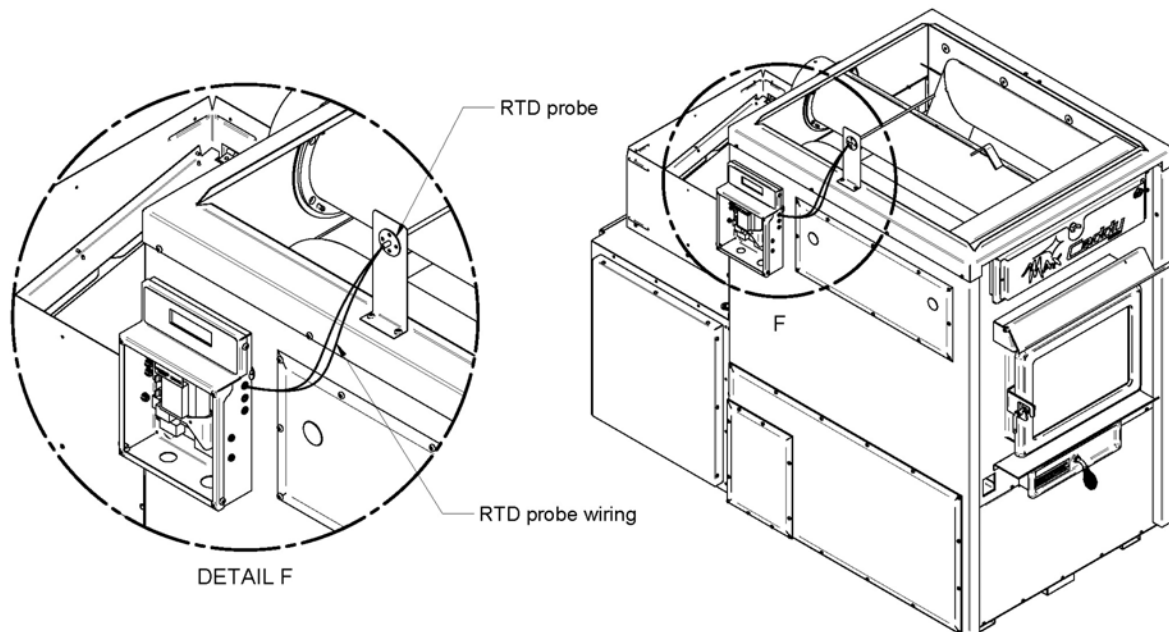

1.5 Servomotor installation and connection

Your Max Caddy furnace is equipped with a servomotor. You need to secure it in place in the two pre-drilled holes using two screws as shown below.

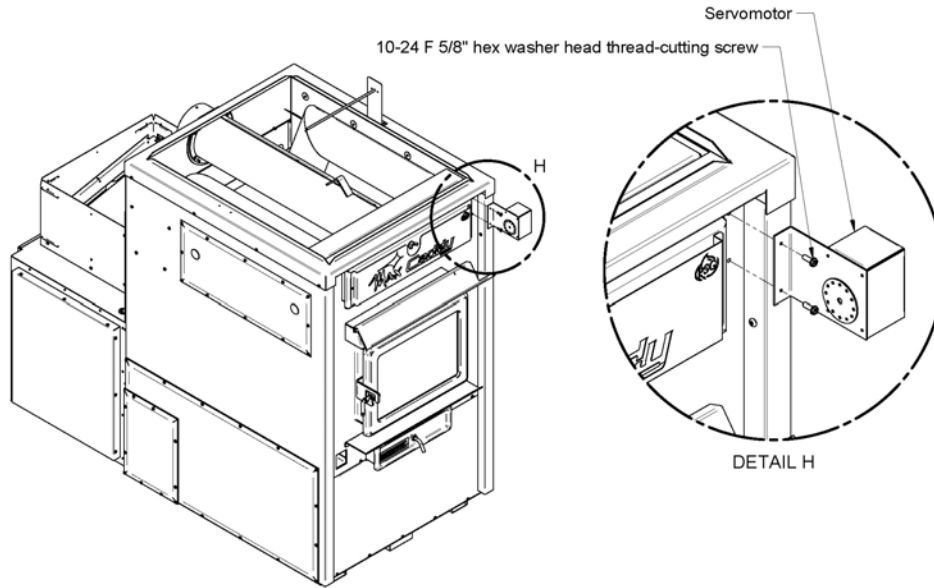

Once installed, you need to install the chain that links the air inlet damper to the servomotor as shown below. For more information regarding this installation, refer to the furnace owner's manual. The chain that links the air inlet damper to the motor must have a play of 1/8" and must be secured in place by the hook. When there is no call for heat, the air inlet damper must be completely closed and the chain must be hooked to the servo-motor at the "8 o'clock" position. For more information regarding this installation, refer to the furnace owner's manual.

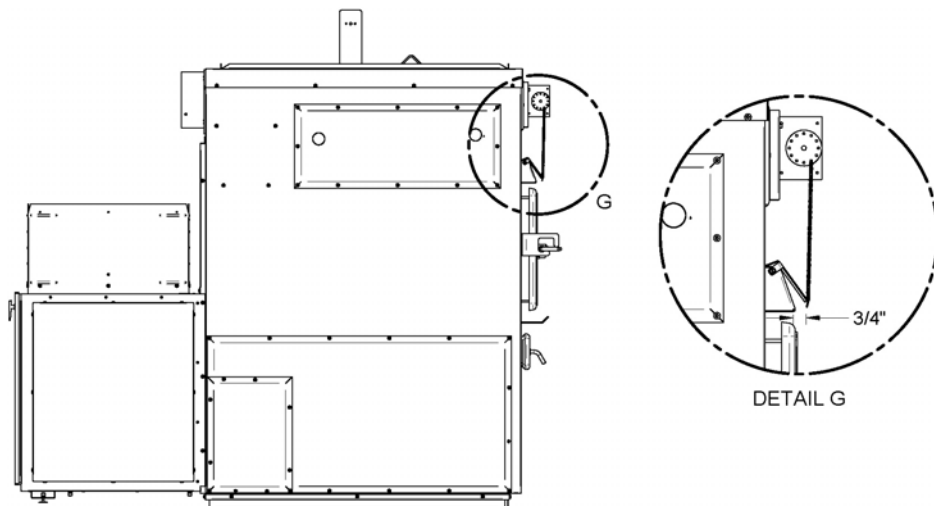

WARNING: USE WIRING SUITABLE FOR 75° C (not supplied)

Then, you need to connect the servomotor to the limiting board. To do so, refer to the electric wiring diagram supplied in the owner's manual of the furnace. To run the wire properly, refer to the drawings below.

Wire running to the limiting board installed on the **LEFT** side of the furnace

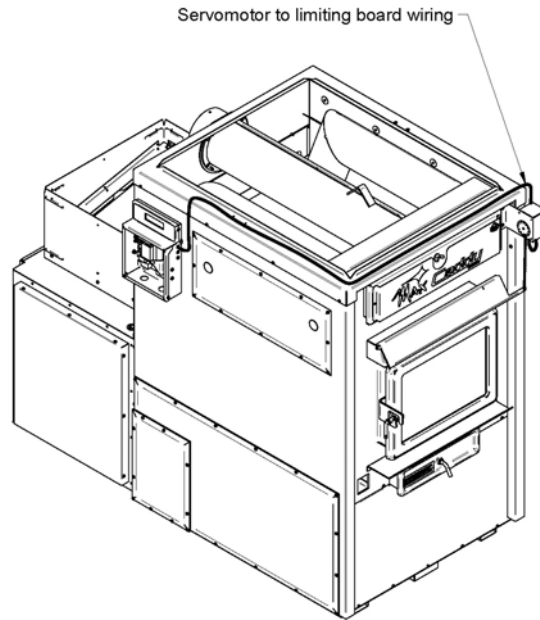

Wire running to the limiting board installed on the **RIGHT** side of the furnace

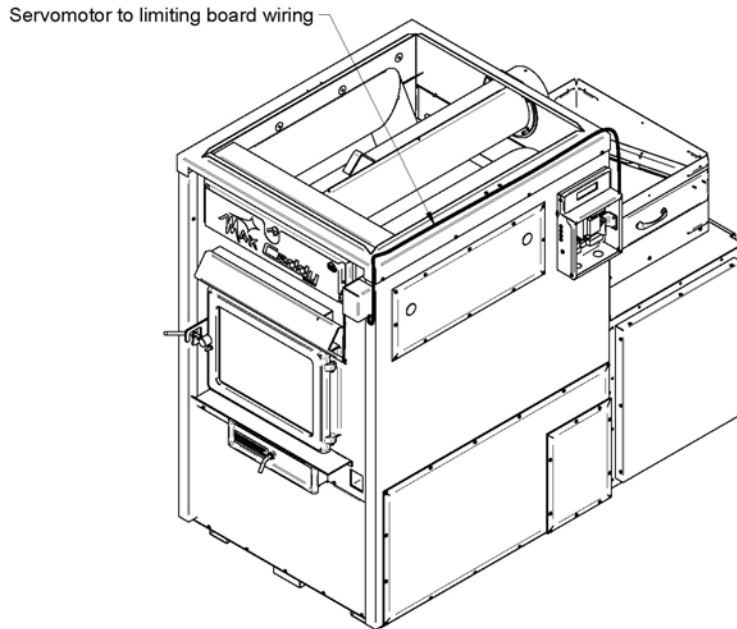

WARNING: USE WIRING SUITABLE FOR 75° C (not supplied)