



Eco-Energy

at the heart of your home

# comfort and peace of mind

Wood heating and the environment	p.2
Why choose a PSG furnace	p.3
Caddy Series and Guidelines for selecting your furnace	p.4
EPA wood and combination furnace - Caddy	p.5-6
EPA wood and combination furnace - Add-on wood furnace	p.7
EPA wood and combination furnace - Mini-Caddy	p.8-9
CSA B415.1 wood - oil- electric trio furnace - Max Caddy	p.10-11
EPA pellet and combination furnace - Caddy Alterna	p.12-13
Wood and combination furnaces - 2000 and 3000 Series	p.14
Suspended fuel oil unit heater - 6500 Series	p.15
Wall mounted gas heaters - Longvie Series	p.16

CATALOG



# Wood Heating and the Environment

When oil, gas, and coal are burned, the carbon they contain is oxidized to carbon dioxide (CO<sub>2</sub>), the main greenhouse gas. In effect, the combustion of fossil fuels releases ancient carbon (carbon that has been buried within the earth for thousands of years), thereby increasing the atmospheric concentration of carbon dioxide (CO<sub>2</sub>). In comparison, wood combustion can be considered carbon neutral because trees absorb CO<sub>2</sub> as they grow. This process is called carbon sequestration. Approximately one ton of carbon is sequestered for each cubic meter of wood. When trees mature, die, fall in the forest and decompose, the same amount of carbon is emitted as would be released if they were burned for heat. This cycle can be repeated forever without increasing atmospheric carbon. A healthy forest is not a museum, but a living community of plants and animals. When trees are used for energy, a part of the forests carbon "bank" is diverted from the natural decay and forest cycle into our homes to heat them. When we heat with wood, we are simply tapping into the natural carbon cycle in which CO<sub>2</sub> flows from the atmosphere to the forest and back. The key to ecologically sound and sustainable wood energy use is to ensure that the forest remains healthy, maintains a stable level of variously aged trees and provides a good habitat for a diversity of other species, both plants and animals. Ensuring there is a healthy fuelwood market is key to a sustainable forestry plan. Landowners have more incentive to remove low value trees and manage their forests sustainably knowing there is a market for this low value material.

The combustion of wood produces small particles that are called PM2.5. Those particles are 30 times smaller than a human hair. They can aggravate certain lung and heart diseases and have been linked with health problems such as asthma. Sources of PM2.5 include combustion under various forms, such as the one used for cars and trucks, wood heating, as well as other industrial processes. While it is true that old technology like open fireplaces and simple heaters could not burn the wood completely, the new generation of wood-burning appliances are designed to burn particles. They produce almost no visible smoke. The wood-heating industry has evolved. The vast majority of appliances sold on the market now meet the particles emissions limits set by the US Environmental Protection Agency as well as the Canadian standard CSA B415.1. For example, the Environmental Protection Agency, better known as EPA, limits emissions of certified wood heating appliances to no more than 7.5 grams per hour. In comparison, older conventional wood appliances average 40 grams per hour. Numerous countries, provinces and municipalities, have adopted laws that regulate the sale of wood-heating appliances that do not meet the latest standards in terms of particles emissions. Among them, we can name the United States, Australia, New Zealand, as well as numerous countries that are part of the European Union. In Canada, British Columbia, Quebec, Nova Scotia, and Newfoundland have also introduced laws regulating the sale of wood-heating appliances.

Wood, when burned in an appliance that has been tested to the EPA or CSAB415.1 standards, emits up to 90% less particles. It is a clean, renewable energy source. Furthermore, the reduction in fuelwood consumption reaches up to 33% when advanced wood combustion systems are used. This is because certified wood appliances are 60% to 80% efficient, compared with 40% to 60% for conventional units. As for appliances burning wood pellets, they have amongst the lowest particulate emissions of all solid-fuel burning appliances. They are manufactured from waste products and other renewable resources right here in North America. They represent a huge source of heating fuel from material that would otherwise be sent to landfills.



**Example of particles\* emissions of a furnace**

<p>30-50 grams / h 2 - 3 g / MJ</p> <p><b>Non-certified unit</b></p>	<p>2-7 grams / h 0.20 - 0.40 g / MJ</p> <p><b>EPA / CSAB415.1-09 certified unit</b></p>
<p><b>Overall efficiency **</b></p> <p>40-60%      60-80%</p>	

\* Fine particles < 2.5 microns  
\*\* Combustion and heat transfer efficiency

# Why choose a PSG furnace?

## Flexibility

PSG is synonymous with flexibility. Our furnaces are designed to provide wood central heating with the added option of an **electric element** or **oil unit**, which automatically comes on if the furnace runs out of wood. What's more, all PSG furnaces are controlled by a wall thermostat that gives you the exact comfort level you want for your home and all the protection you need from winter's icy blasts! Whether you're there or not to add wood, you'll enjoy comfortable central heating **without interruption**. And you'll never again be dependent on a single source of energy to guarantee the comfort and safety of your family.

## Design

Not all furnaces are created equal. Compare and you'll see the advantages in owning a PSG furnace.

**Compact combination models** : there's much more to the concept behind our combination furnace than joining together two furnaces that use different energy sources. You know how important it is to **maximize the usable space** in your home. So if you choose the electrical or oil option to go with wood, your PSG furnace will not require any additional space. That's because the electric element or oil unit is fully integrated into the furnace, beneath the combustion chamber.

**A furnace designed to last** : the combustion chamber in your PSG furnace is entirely lined with heat-resistant bricks, giving it exceptional durability. And the steel it uses is 3/16 inch thick, which is your best guarantee for many years of use. The outer walls are treated with a special zinc-base coating to provide long-term rust protection. You can thus install your furnace with full peace of mind in a basement or any other place where the humidity level may be higher.

**Easy maintenance** : PSG has made furnace cleaning easier than ever before. Our furnaces come with a practical 16-inch long ash drawer that allows a large quantity of ashes to accumulate before they have to be removed.

## Performance

No-one today considers using wood as a heating source without first looking at its energy efficiency and environmental impact. PSG furnaces are built with these concerns squarely in mind. The hot gases and smoke wind their way through a fire screen and out the chimney. The result is superb efficiency and a significant reduction of polluting emissions and creosote deposits in the chimney. Thanks to its ingenious design, your PSG furnace will heat your home over the entire night with a single load of wood.†

## Multiple uses

Whatever your needs – residential or light commercial – there's the right PSG furnace for you.

† May vary subject to location in home, chimney draft, chimney diameter, locality, heat loss factors, climate, and fuels.

# Guidelines for selecting your furnace

Area to heat	Model*
600 to 1,100 square feet	PSG2000 / Mini-Caddy / Caddy Alterna
1,000 to 1,500 square feet	PSG3000 / Caddy Alterna
800 to 1,700 square feet	Caddy / Caddy Alterna
1,500 to 2,000 square feet	Max Caddy / Caddy Alterna
1,800 to 3,000 square feet	Max Caddy / Caddy Alterna

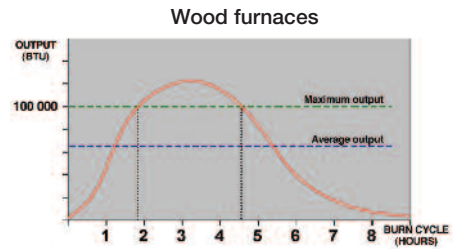
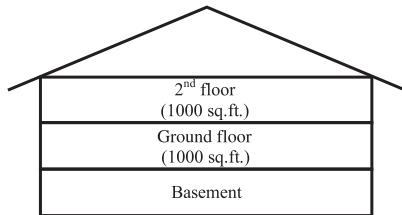

## Estimate of the area to heat

Assuming that the furnace is located in the basement, take 100% of the ground floor surface and add 50% of the 2<sup>nd</sup> floor. For instance, a home with a ground floor and second floor each having a surface of 1,000 square feet will require a furnace capable of heating a minimum area of 1,500 square feet: 1,000 sq.ft. + (1,000 sq.ft. x 50%) = 1,500 sq.ft. Please note that this estimate does not replace a detailed calculation performed by a heating specialist.

## Notes\*

Each home is unique and may require an appliance with a higher or lower heat output. Numerous factors may influence the size and type of model required. Those factors include, but are not limited to: overall insulation of walls and windows, ceiling height, the number of windows, exposition to wind, geographical area (climate), and the temperature comfort zone required by the occupants of the house. It is highly recommended that you consult a heating specialist for both the selection of your furnace and its installation. The heating specialist's judgment is required. The user must also take into consideration that a wood appliance is rarely used at a continuous output level. The maximum heat output is reached during approximately 30% of a regular combustion cycle.

## Caddy series



The Caddy furnaces are designed to provide wood or pellet central heating with the added option of an electric or oil unit. If you are looking for the latest technology in central heating equipment, Caddy furnaces are the answer.

# EPA wood and combination furnace

caddy series

caddy

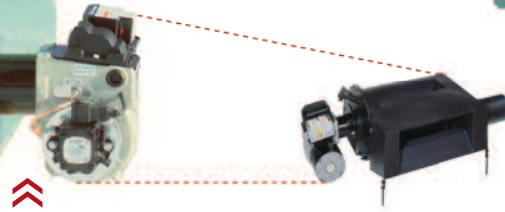

⌆ The fuel oil system's combustion chamber simply slides underneath the firebox.



⌈ The heat exchangers clean-up is quickly and easily done through an access trap located at the front of the furnace.

⌋ The optional insulated vestibule guarantees a quiet performance.



## The Cadillac of furnaces!

The Caddy furnace comes with the same dimensions and basic features as its cousin, the PSG 3000 (see page 14). But its highly advanced combustion technology sets it apart from all others. The Caddy is specifically designed to meet the highest combustion standards in North America today, those of the Environmental Protection Agency (EPA). As such, it is one of the cleanest and most efficient furnaces ever produced by PSG, with savings in heating wood of up to 30% and reductions in particles emissions reaching 90%. One look at the fire through the glass door of the Caddy and you'll see why!

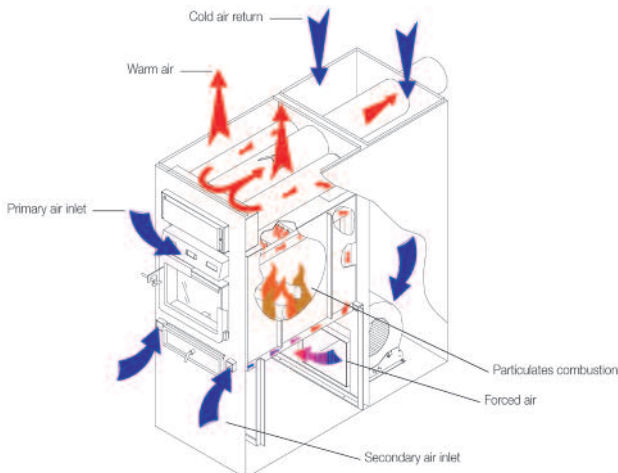

The Caddy EPA wood furnace has a secondary air source. The air is pre-heated before it is injected through the perforated stainless steel air tubes located underneath the firebox baffle. This creates a second combustion of particles emissions before they are released into the atmosphere. You burn less wood and you help the environment.

## A unique heat exchanger system

The Caddy provides exceptional efficiency because of its unique **heat exchanger system**. The cylinder-shaped smoke ducts inside the furnace serve as its heat exchangers and ensure rapid heat transfer because of their ideal diameter and thickness. Hot gases wind their way around the **C-cast baffle** in the combustion chamber and then into the exchangers above it before reaching the main smoke pipe. The heat, which normally dissipates directly into the chimney, instead circulates inside the furnace. The furnace's powerful fan then extracts and pushes all this heat into your heating ducts in uniform fashion throughout the house.

## Carefree cleaning

Forget the complicated cleaning that requires you to disconnect and move your furnace! The Caddy has a fully **accessible trap door** right in front of the furnace, from where you can directly clean the heat exchangers and smoke pipe. All you have to do is brush the combustion residue into the combustion chamber and then collect it using the ash drawer.

### Technical data

furnace and components	CADDY
<b>Fuel</b>	wood
Maximum input capacity	140,000 BTU (41 kW)
Maximum output capacity	106,400 BTU (31.2 kW)
Average output capacity	69,160 BTU (20.3 kW)
Thermostatically controlled	yes
Optimum efficiency	76%
Average emissions	6.6 grams / hour
Loading capacity	up to 55 lbs (25 kg)
Flue spigot diameter	6"
Recommended exhaust pipe diameter	6" if installed as wood or wood-electric combination 7" if installed as wood-oil combination
Type of chimney required	2100°F (1150°C)
Recommended chimney diameter	6" if installed as wood or wood-electric combination 7" if installed as wood-oil combination
Furnace exterior dimensions	26"W x 47"D x 48"H
Firebox dimensions	17"W x 22.5"D x 16"H
Door opening dimensions	13,75"W x 10"H
Door type	glass with cast iron frame
Hot air plenum dimensions	24,5"W x 28,25"D
Cold air plenum dimensions	24,5"W x 15,75"D
Ash pan dimensions	12"W x 16"D x 3"H
Number of filters	2
Filters dimensions	12"W x 24"D x 1"H
<b>Blower</b>	1/3 HP Direct drive Four speed, 1300 cfm
Steel thickness (firebox)	3/16"
Minimum clearance (front)	48"
Minimum clearance (rear)	24" recommended for servicing
Minimum clearance (sides)	24" recommended for servicing
Minimum clearance (ducts)	6" for the first 6 feet and 1" thereafter
Recommended service clearance	24"
Weight	560 lbs (254 kg)
Color	Green
Warranty	Limited lifetime warranty
Safety tests standard	Can CSA B366.1-M91, CSAB212-93, UL391 3e, Ed. rev. 1999
Emissions / Efficiency - test standard	EPA / CSA B415.1
Maximum log length	22"

### Optional electric elements

	CADDY
Output - recommended electric element	18 kW
Output - other optional electric elements	15, 20 kW
Element location	left
Recommended service clearance (element)	24"

### Optional fuel oil burner

	CADDY
Input capacity	91,000 BTU (27 kW)
Burner orifice	0,65 gal/hr.* (2,46 l/hr.)
Pump pressure	120 PSI
Standard burner	Beckett AFG
Other approved burners	Riello, Aero
Efficiency	82%
Burner location	right
Recommended service clearance (burner)	24"
Optional insulated vestibule for burner	yes
Recommended exhaust pipe diameter	5"
Exhaust pipe location	left

\* US Gallon (1 US Gallon = 0,83 Imperial Gallon)

# EPA Add-on wood furnace

caddy series

# caddy add-on



## Example

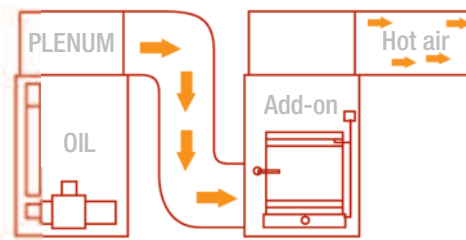

If you already have a forced air central heating system that uses oil, gas, or electricity and you want the flexibility of using wood with it, the PSG Caddy Add-on is the ideal choice. This unit, which can be installed on the left or right side of your existing system, shares the furnace's controls and fan, giving you a fully harmonized wood/oil, wood/gas, or wood/electric combination system.

The Caddy Add-on has been specifically designed to meet the most stringent combustion standards in North America, namely those applied by the Environmental Protection Agency (EPA). The Caddy Add-on, which provides up to 30% savings in heating wood and a reduction in particles emissions of up to 90%, is one of the cleanest and most efficient products ever produced by PSG. You'll see why when you contemplate the fire through the **glass door** of your Caddy Add-on!

## Technical data

wood add-on and components	CADDY ADD-ON
Fuel	wood
Existing furnace	fuel oil, gas, electric
Maximum input capacity	140,000 BTU (41 kW)
Maximum output capacity	106,400 BTU (31.2 kW)
Average output capacity	69,160 BTU (20.3 kW)
Optimum efficiency	76%
Average emissions	6.6 grams / hour
Loading capacity	up to 55 lbs (25 kg)
Flue spigot diameter	6"
Recommended exhaust pipe diameter	6"
Recommended chimney diameter	7"
Furnace exterior dimensions	25,75"W x 29,5"D x 48"H
Firebox dimensions	17"W x 22,5"D x 16"H
Door opening dimensions	13,75"W x 10"H
Door type	Glass with cast iron frame
Connection with existing furnace	left or right
Air inlet duct dimensions	14,5"H x 22"W
Hot air plenum dimensions	24,5"W x 28,25"D
Ash pan dimensions	12"W x 16"D x 3"H
Steel thickness (firebox)	3/16"
Minimum clearance (front)	48"
Minimum clearance (rear)	24"
Minimum clearance (sides)	6"
Minimum clearance (ducts)	6" for the first 6 feet and 1" thereafter
Weight	445 lbs (202 kg)
Color	green
Warranty	Limited lifetime warranty
Safety tests standard	CSA B366.1-M91, ANSI/UL 391-2004
Emissions / Efficiency - test standard	EPA / CSA B415.1
Maximum log length	22"

# EPA wood and combination furnace

caddy series

## mini-caddy



Standard galvanized steel plenum. >>>



PSG distribution box including a 12" round hot air plenum kit with 5" outlets. >>>



5" outlets



### Making the most of your space

The Mini-Caddy, as its name suggests, is the miniature version of the Caddy. It is specially designed for the smallest spaces, and is thus ideal for small homes, cottages and small commercial buildings. This high-efficiency furnace uses the same combustion technology as the Caddy, and thus guarantees the same exceptional cleanliness and combustion time.

### A hot air distribution system that's simplicity itself

The hot air distribution system in the Mini-Caddy has a unique distribution duct that allows immediate start-up in eight different directions using 5" round outlets. The system is also designed to work with a standard 12" x 12" hot air plenum.

### Add style to any room!

With its avant-garde style and round plenum linked to a distribution duct that can be easily concealed under a ceiling, the Mini-Caddy lends its elegance to any room. So there's no need for an enclosed space to hide your furnace! The Mini-Caddy combines all the advantages of a furnace with the graceful beauty of a wood stove.



 The PSG distribution box also includes a cold air return adaptor to receive up to eight 5" round inlets.

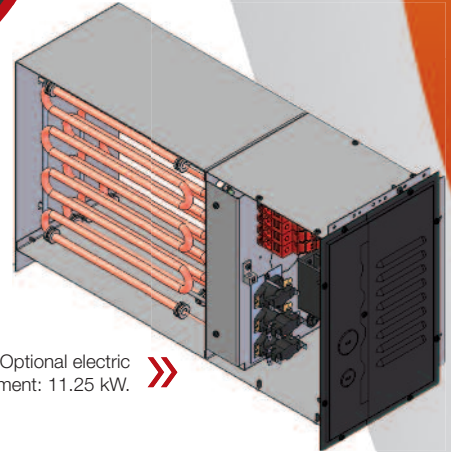

 Optional electric element: 11.25 kW.

## Technical data

furnace and components	MINI-CADDY
Fuel	wood
Maximum input capacity	75,000 BTU (21.6 kW)
Maximum output capacity	63,750 BTU (18.7 kW)
Average output capacity	41,440 BTU (12.2 kW)
Thermostatically controlled	yes
Optimum efficiency	85%
Average emissions	6 grams / hour
Loading capacity	up to 30 pounds (14 kg)
Flue spigot diameter	6" (152 mm)
Recommended exhaust pipe diameter	6" (152 mm)
Type of chimney required	2100°F (1150°C)
Recommended chimney diameter	6" (152 mm)
Furnace exterior dimensions	23 1/4"W x 39 3/4"D x 45 5/8"H
Firebox dimensions	14"W x 19 3/8"D x 12"H
Door opening dimensions	13 1/2"W x 9 5/8"H
Door type	glass with cast iron frame
Hot air plenum dimensions	12" x 12" OR 12" round using the PSG distribution box
Cold air plenum dimensions	22 3/8"W x 13 5/8"D OR adapter plate with eight 5" outlets (supplied with the PSG distribution box)
Ash pan dimensions	11 3/4"W x 12"D x 2 5/8"H
Number of filters	1
Filters dimensions	15"W x 20"D x 1"H
Blower	1/4 HP Direct drive Four speed
Steel thickness (firebox)	3/16" (5 mm)
Minimum clearance (front)	48"
Minimum clearance (rear)	24" recommended for maintenance
Minimum clearance (sides)	24" recommended for maintenance
Minimum clearance (ducts)	3" for the first 6 feet and 1" thereafter
Recommended service clearance	24"
Weight	405 lbs (184 kg)
Color	Black
Warranty	Limited lifetime warranty
Safety tests standard	Can CSA B366.1-M91, CSA C22.2 No. 236, UL 1995, UL391 3e Ed. rev. 1999
Emissions / Efficiency - test standard	EPA / CSA B415.1
Maximum log length	18"

## Optional electric elements

	MINI-CADDY
Output - recommended electric element	11.25 kW
Output - other optional electric elements	N/A
Element location	left
Recommended service clearance (element)	24"

10

Max Caddy  
CSA B415.1 wood-oil-electric trio furnace  
caddy series

# CSA B415.1 wood-oil-electric trio furnace

caddy series



max caddy



The oil exhaust pipe can be located on the right or left side of the furnace. >>

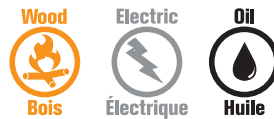

The Max Caddy is the first furnace in the world which can be installed as a wood-oil-electric trio. It is an extra large, ingenious, clean-burning wood furnace. As opposed to all conventional wood furnaces, the Max Caddy uses a PC board that allows the user to connect all four blower speeds. In other words, it is an intelligent furnace. With the logic built into our PC board, the furnace automatically selects the most appropriate blower speed in order to maintain the furnace's plenum temperature at its best efficiency point. This allows the homeowner to obtain heat even at the tail end of the combustion cycle

because the furnace has the flexibility to run with the lowest blower speed available. This would simply not be possible with a conventional wood furnace because it must be configured to operate with one single blower speed. That speed is normally too powerful for low burn cycles because it cools off the unit's firebox too much. This exclusive Max Caddy feature not only results in better comfort, but it also extends the unit's cycling intervals, leading to substantial fuel economies.



Optional top cold air plenum. >>

Optional electric element. >>

The Max Caddy has been designed using the latest CSA B415.1 Standard, the most advanced standard for testing emissions and efficiency of solid-fuel central heating systems. The Max Caddy boasts an 82% efficiency and average emissions of 5.9 g/h ! The Max Caddy can be installed as a wood-only unit, a wood-electric combo, a wood-oil combo, or a wood-oil-electric trio ! Furthermore, this environmentally friendly furnace is designed to allow the installation of an electric element or an oil burner on both sides of the furnace, making the installation and maintenance more flexible. Other options such as a hot water loop kit for pre-heating domestic water, a fresh air intake adapter, and a top cold air plenum kit make it one of the most versatile and ingenious central heating systems on the market.

## Technical data

furnace and components		MAX CADDY
Fuel		wood
Maximum input capacity		180,000 BTU (53 kW)
Maximum output capacity		137,970 BTU (41 kW)
Average output capacity		89,680 BTU (27 kW)
Thermostatically controlled		yes
Optimum efficiency		82%
Average emissions		5.9 grams / hour or 0,20 g/MJ
Loading capacity		up to 90 lbs (41 kg)
Flue spigot diameter		6"
Recommended exhaust pipe diameter		6" if installed as wood or wood-electric combination 7" if installed as wood-oil combination
Type of chimney required		2100°F (1150°C)
Recommended chimney diameter		6" if installed as wood or wood-electric combination 7" if installed as wood-oil combination
Furnace exterior dimensions		30"W x 62"D x 50"H
Firebox dimensions		20 3/8"W x 26 1/4"D x 14 1/2"H
Door opening dimensions		15 11/16"W x 10"H
Door type		glass with cast iron frame
Hot air plenum dimensions		25 7/16"W x 32 1/8"D
Cold air plenum dimensions		19 15/16"W x 17 15/16"D
Ash pan dimensions		12"W x 19 5/8"D x 2 5/8"H
Number of filters		1
Filters dimensions		16"W x 20"D x 1"H
Blower		G-10 blower with 1/2 hp motor 1780 CFM (maximum at 0.20" WC) - 4 speeds
Steel thickness (firebox)		3/16"
Minimum clearance (front)		48"
Minimum clearance (rear)		24"
Minimum clearance (sides)		6" (wood only) and 24" on the option side
Minimum clearance (ducts)		6" for the first 6' with a shield at 1 1/2", and 1" thereafter
Recommended service clearance		24"
Weight		650 lbs (295 kg)
Color		Green
Warranty		Limited lifetime warranty
Safety tests standard		Can CSA B366.1, UL 391, CAN/CSA C22.2 no 236, UL 1995, CSA B140.4, UL 727
Emissions / Efficiency - test standard		CSAB415.1-10
Maximum log length		25"

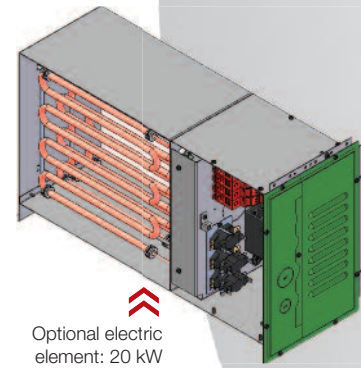

Optional electric element: 20 kW or 25 kW.



Optional hot water loop kit for pre-heating domestic water.

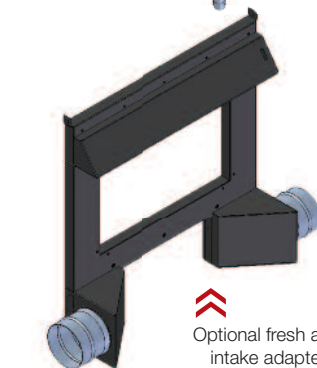

Optional fresh air intake adapter.



### Top cold air plenum option

MAX CADDY	
Plenum dimensions	19 15/16" W x 17 15/16" D

### Optional electric element

MAX CADDY	
Output - Recommended element	20 kW / 68,000 BTU
Output - Other optional elements	25 kW / 85,000 BTU
Element location	Left or right

### Optional oil burner

MAX CADDY	
Input #1	91,000 BTU
Input #2	120,000 BTU
Burner orifice at input #1	0,65 70"W (Beckett) / 0,50 70"W (Riello)
Burner orifice at input #2	0,65 70"W (Beckett) / 0,65 70"W (Riello)
Pump pressure at input #1	100 PSI (Beckett) / 150 PSI (Riello)
Pump pressure at input #2	175 PSI (Beckett) / 165 PSI (Riello)
Efficiency at input #1	Beckett (85%) / Riello (87%)
Efficiency at input #2	Beckett (83%) / Riello (85%)
Standard burner	Beckett
Burner location	Left or right
Optional insulated vestibule	no
Recommended exhaust pipe diameter	5"
Exhaust pipe location	Left or right

### Optional hot water loop kit for pre-heating domestic water

MAX CADDY	
Connection location	Left or right
Connecting pipe diameter	3/4"
Back-up tank volume	60 gallons (227 liters)

### Optional fresh air intake adapter

MAX CADDY	
Connection location	Right
Connecting pipe diameter	5"



Optional Beckett oil burner.

# EPA High-tech pellet furnace

## caddy series



# alterna



PC board. >>>



LCD touch-screen. >>>



The Caddy Alterna is a 120,000 BTU warm-air pellet furnace. With its 240-pound hopper capacity and its efficiency topping the 81% mark, it is the perfect heating device for the coldest North American winters. Its state-of-the-art LCD control panel lets you configure the furnace rapidly and easily. The bottom-feed burner system has been tested with four different types of pellets: standard wood pellets, 100% bark pellets, sawdust/hay mix pellets, and switch grass pellets. This flexibility in fuel selection will allow you to keep more money in your pocket and avoid potential fuel shortages. But versatility does not end there. The Caddy Alterna can accept an optional electric element that can be installed on either side of the furnace. What's more, the maximum BTU on the Caddy Alterna may be adjusted by the homeowner or installer. Indeed, the PC board allows three additional input configurations: 60,000BTU, 80,000BTU, and 100,000BTU. For smaller homes, this input selection flexibility will result in extended cycling intervals and will lead to fuel economies. In terms of heating capacity, homeowners must also realize the benefits of the regulated feed rate provided by a pellet furnace like the Caddy Alterna. As long as there is fuel in the hopper and thermostatic demand, the Caddy Alterna will consistently produce the desired maximum heat output. No wonder it can heat up to 3,000 square feet!

## Technical data

furnace and components	CADDY ALTERNA
Fuel	wood pellets and biomass pellets*
Maximum input capacity	120,000 BTU (36 kW)
Maximum output capacity	108,000 BTU (32 kW)
Minimum input capacity	18,000 BTU (6 kW)
Minimum output capacity	16,000 BTU (5 kW)
Optimum efficiency	81%
Average emissions	4.2 grams/hour
Blower	G-10 blower with 1/2 hp motor - 1650 CFM (max 0.20" WC) - 4 speeds
Ignition type	electronic
Temperature control	thermostatic
Loading capacity	240 lbs (109 kg)
Combustion autonomy on minimum	100 hours (pilot mode)
Combustion autonomy on maximum	17 hours
Average combustion autonomy	30 to 50 hours (thermostatic cycling at 120,000 BTU)
Door type	Glass with cast iron frame
Color	Green
Exterior dimensions	26 1/4"W x 56 1/4"D x 47"H
Required exhaust pipe diameter	4"
Exhaust pipe type	Pellet vent approved per UL-641 / ULC S-609-M89
Hot air plenum dimensions	22"W x 22"D
Cold air plenum dimensions	16 1/8"W x 21 5/16"D
Ash drawer dimensions	20"W x 14"D x 7 3/4"H
Number of filters	1
Filters dimensions	16" x 20"
Minimum clearance (front)	48"
Minimum clearance (back)	24"
Minimum clearance (sides)	4" (pellet only) and 24" on the option side
Minimum clearance (ducts)	2" for the first 5', and 0" thereafter
Weight	500 lbs (227 kg)
Warranty	Limited lifetime warranty
Test standard - Safety	CAN/CSA B366.1, UL 391, CAN/CSA C22.2 no 236, UL 1995, ASTM E1509, ULC/ORD-C1482
Emissions / Efficiency - test standard	EPA / CSA B415.1

\* Standard wood pellets, sawdust / hay mix pellets, 100% bark pellets, switch grass pellets.

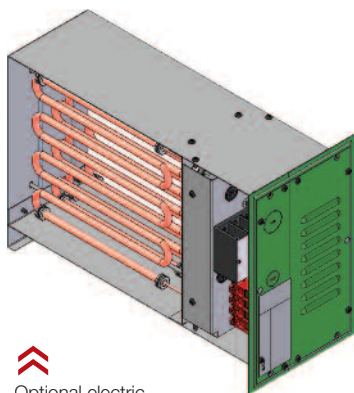

Optional electric element: 15 kW or 20 kW.

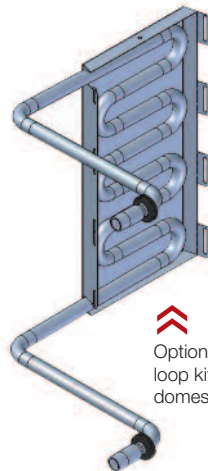

Optional hot water loop kit for pre-heating domestic water.



Optional fresh air intake adapter.

### Optional electric element

CADDY ALTERNA	
Output - recommended electric element	15 kW or 20 kW
Element location	Left or right

### Optional fresh air intake adapter

CADDY ALTERNA	
Connection location	Left or right
Connecting pipe diameter	5"

### Optional hot water loop kit for pre-heating domestic water

CADDY ALTERNA	
Connection location	Left or right
Connecting pipe diameter	3/4"
Back-up tank volume	60 gallons (227 liters)

New option

**QUICK-START  
IGNITION**

 **novoclimat**

**Caddy Alterna**  
EPA high-tech pellet and  
combination furnace  
caddy series

13

# Wood and combination furnaces

## 2000 and 3000 series

Below, a PSG 2000 wood-oil combo shown with the burner's exhaust pipe coming out on the left side.



Below, a PSG 3000 wood-electric combo shown with the electrical element accessible from the left side.



The electric element simply slides underneath the firebox. >>>

### Technical data

furnace and components	PSG 2000	PSG 3000
Fuel	wood	wood
Maximum input capacity	75,000 BTU (21.9 kW)	120,000 BTU (35.2 kW)
Maximum output capacity	47,250 BTU (13.9 kW)	75,600 BTU (22.2 kW)
Average output capacity	30,715 BTU (9 kW)	49,140 BTU (14.4 kW)
Thermostatically controlled	yes	yes
Loading capacity	up to 35 lbs (16 kg)	up to 60 lbs (27 kg)
Flue spigot diameter	6"	6"
Recommended exhaust pipe diameter	6"	6" or 7" **
Type of chimney required	2100F (1150°C)	2100F (1150°C)
Recommended chimney diameter	6"	6" or 7" **
Furnace exterior dimensions	23,5"W x 46"D x 46"H	26"W x 47"D x 48"H
Firebox dimensions	14"W x 22"D x 12,5"H	16"W x 26"D x 16"H
Door opening dimensions	12"W x 13"H	12"W x 13"H
Door type	Double plate steel	Double plate steel
Hot air plenum dimensions	22,25"W x 26,25"D	24,5"W x 28,25"D
Cold air plenum dimensions	22,25"W x 15,75"D	24,5"W x 15,75"D
Ash pan dimensions	12"W x 16"D x 3"H	12"W x 16"D x 3"H
Number of filters	2	2
Filters dimensions	11"W x 20"D x 1"H	12"W x 24"D x 1"H
Blower	1/3 HP Direct drive Four speed, 950 cfm	1/3 HP Direct drive Four speed, 1300 cfm
Steel thickness (firebox)	3/16"	3/16"
Minimum clearance (front)	48"	48"
Minimum clearance (rear)	29" recommended for servicing	29" recommended for servicing
Minimum clearance (sides)	24" recommended for servicing	24" recommended for servicing
Minimum clearance (ducts)	6" for the first 6 feet and 2" thereafter	6" for the first 6 feet and 2" thereafter
Recommended service clearance (blower)	29"	29"
Weight	450 lbs (205 kg)	540 lbs (245 kg)
Color	Green	Green
Warranty	Limited lifetime warranty	Limited lifetime warranty
Tests standard	Can CSA B366.1-M91, CSAB212-93, UL391 3e Ed. rev. 1999	Can CSA B366.1-M91, CSAB212-93, UL391 3e Ed. rev. 1999
Maximum log length	20"	24"

### Optional fuel oil burner

	PSG 2000	PSG 3000
Input capacity	85,000 BTU (25 kW)	91,000 BTU (27 kW)
Burner orifice	0,65 gal/hr.* (2,46 l/hr.)	0,65 gal/hr.* (2,46 l/hr.)
Pump pressure	110 PSI	120 PSI
Standard burner	Beckett AFG	Beckett AFG
Efficiency	82%	82%
Burner location	right	right
Recommended service clearance (burner)	24"	24"
Optional insulated vestibule for burner	no	yes
Recommended exhaust pipe diameter	5"	5"
Exhaust pipe location	left	left

### Optional electric elements

	PSG 2000	PSG 3000
Output - recommended electric element	15 kW	18 kW
Output - other optional electric elements	18 kW	15, 20, 25 kW
Element location	left	left
Recommended service clearance (element)	24"	24"

\* US Gallon (1 US Gallon = 0,83 Imperial Gallon)

\*\* 6" if installed as wood or wood-electric combination or 7" if installed as wood-oil combination

# Suspended fuel oil unit heater

6500 series

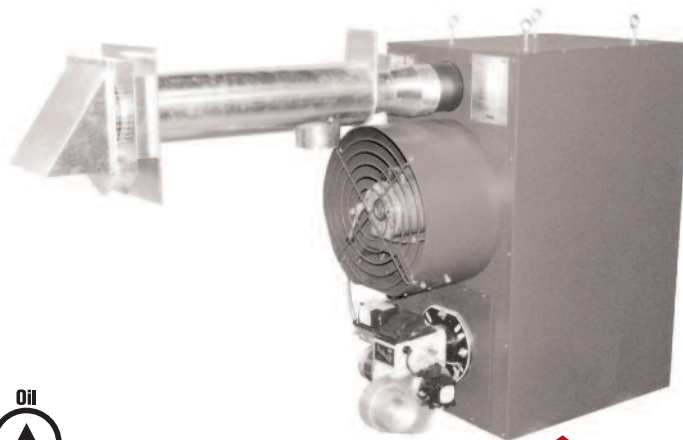
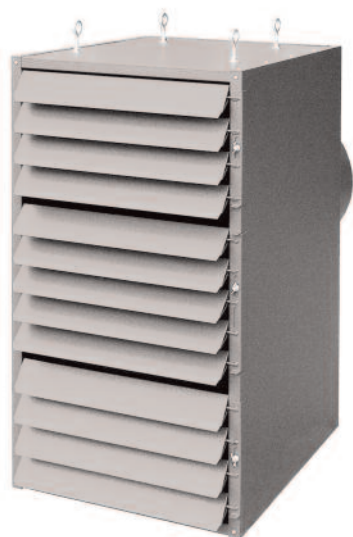

Rear view with direct-vent system

15  
6500  
Suspended fuel oil unit heater  
6500 series

## Ideal for commercial and industrial buildings

The suspended PSG 6500 fuel oil unit heater is designed for **commercial** and **industrial** uses. It is a simple and reliable product that your enterprise can count on. Even though it is designed to be suspended, the PSG 6500 can also be installed on a non-combustible stand with clearance space of 6 inches to the combustible floor material. The adjustable louvers at the front of the PSG 6500 enable you to direct the heat where you most need it.

## Easy to install

The PSG 6500 can be installed conventionally, i.e., with a chimney or directly through a wall with the PSG direct vent kit. This flexibility gives you all the options whether you install your PSG 6500 in a new building or use it to replace an old space heater.

## Technical data

unit heater and components	PSG 6500
Fuel	oil
Type of venting	With chimney or direct-vent
Input capacity	90,000 BTU (26 kW)
Output capacity	75,000 BTU (22 kW)
Burner orifice	0,65 gal/hr.* (2,46 l/hr.)
Standard burner model	Beckett AFG
Efficiency	83.4%
Thermostatically controlled	yes
Recommended exhaust pipe diameter	5"
Type of chimney required	L-vent for oil or PSG DV Kit
Recommended chimney diameter	5"
Unit heater exterior dimensions	20"W x 37"D x 39"H
Blower	1/6 HP 16" Dia., 22° pitch 1075 rpm / 1750 cfm 16 Ga H.R.
Steel thickness (combustion chamber)	16 Ga H.R.
Adjustable louvers	yes
Minimum clearance (underneath the unit)	6"
Minimum clearance (front of unit)	48"
Minimum clearance (rear of unit)	24"
Minimum clearance (side of unit)	6"
Recommended service clearance (burner)	24"
Weight	190 lbs (86 kg)
Color	grey
Warranty	Limited lifetime warranty
Safety tests standard	CSA B140.4 (C2001), UL731-1995

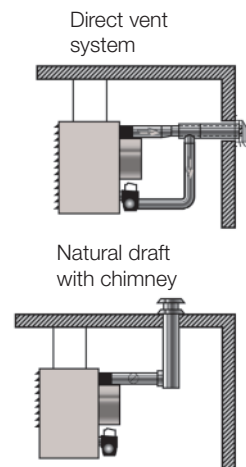

\* US Gallon (1 US Gallon = 0,83 Imperial Gallon)

# Wall mounted gas heaters



## Longvie series

### Functional, simple and elegant

Wall gas heaters aren't what they used to be. No more square boxes! With the Longvie wall heaters, you can now heat the space you want to, with style and efficiency. The blue and yellow flame is always visible when your heater is operating, and a thermostat forming part of the heating unit increases or decreases the gas flow to keep the heat at the desired level. The Longvie wall heaters also come with a vent kit that allows the gas to be vented through a coaxial pipe positioned directly behind the unit. This is a fully-sealed combustion/exhaust system that **does not require a chimney**. And **no electrical source is required** to operate the Longvie heaters, apart from the optional blower on model DV 20.



DV-20



DV-12

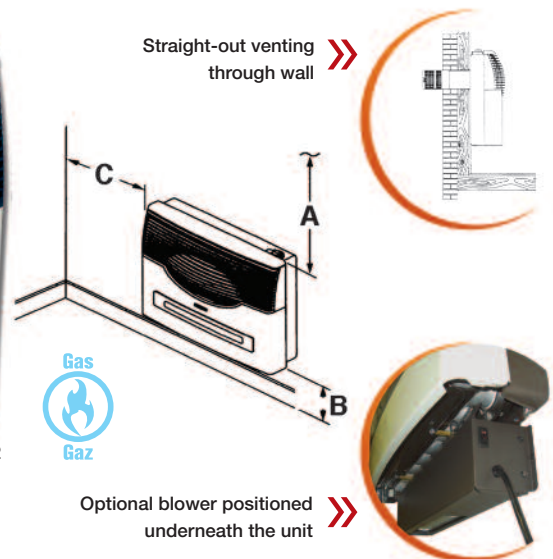

Straight-out venting  
through wall



Optional blower positioned  
underneath the unit

(DV 20 only)

### Technical data

wall heater and components	DV20	DV12
Fuel	natural gas or propane	natural gas or propane
Cabinet color	ivory	ivory
Grille color	anthracite	anthracite
Maximum input - NG or LP	18,000 BTU (5,3 kW)	10,000 BTU (2,9 kW)
Minimum input - NG or LP	6,000 BTU (1,8 kW)	3,100 BTU (0,9 kW)
Maximum output - NG or LP	13,500 BTU (4 kW)	7,500 BTU (2,2 kW)
Minimum output - NG or LP	4,500 BTU (1,3 kW)	2,170 BTU (0,6 kW)
Efficiency	75%	75%
Gas inlet diameter	3/8"	3/8"
Venting system included	yes	yes
Exhaust pipe diameter	6" X 3,5"	4,25" X 2,5"
Maximum wall thickness	13,5"	13,5"
Minimum wall thickness	4,5"	4,5"
Security control	Overheat cut-off switch	Overheat cut-off switch
Unit dimensions	26"W x 22,63"H x 8,25"D	15"W x 22,63"H x 7 1/8"D
Optional blower	yes	no
Minimum clearance (top) A	24"	24"
Minimum clearance (floor) B	7"	7"
Minimum clearance (sides) C	6"	6"
Weight	54 lbs (24 kg)	30 lbs (13,6 kg)
Warranty	Limited 5 years	Limited 5 years
Tests standard	ANSI Z21.86b, CSA 2.32b 2002	ANSI Z21.86b, CSA 2.32b 2002



at the heart of your home

250, rue de Copenhague  
St-Augustin-de-Desmaures  
Quebec (Canada) G3A 2H3  
Telephone : (418) 878-3078  
Fax : (418) 878-3001

[www.psg-distribution.com](http://www.psg-distribution.com)

Authorized dealer



Mixed Sources

Product group from well-managed forests  
and other controlled sources  
[www.fsc.org](http://www.fsc.org) Cert no. SCS-COC-0050  
©1996 Forest Stewardship Council

PUB046A



7 7 3 3 8 8 9 9 5 1 9 9